

# radicon



with you at every turn

# benzlers



with you at every turn

Series G Industrial Reducers

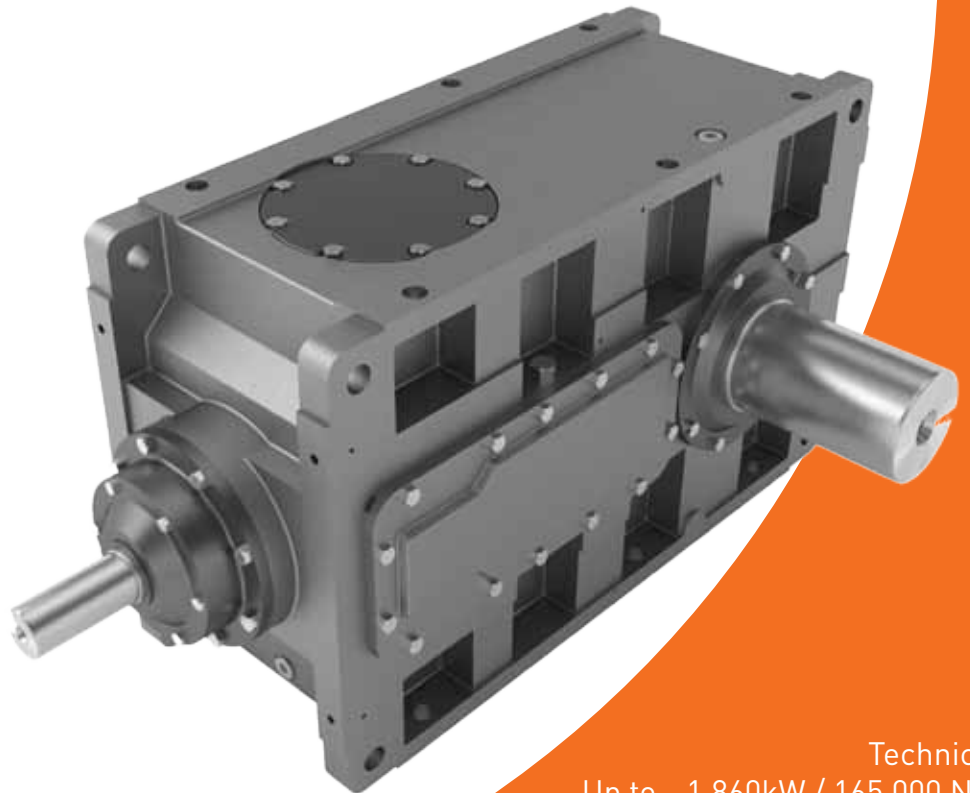

Technical  
Up to - 1,860kW / 165,000 Nm

Industrial Reducers  
CG-2.00GB1113

# PRODUCTS IN THE RANGE

Serving an entire spectrum of mechanical drive applications from food, energy, mining and metal; to automotive, aerospace and marine propulsion, we are here to make a positive difference to the supply of drive solutions.

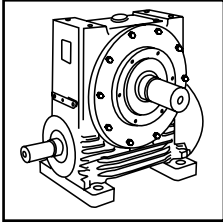

**Series A**  
Worm Gear units and geared motors in single & double reduction types

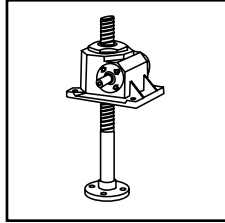

**Series BD**  
Screwjack worm gear unit

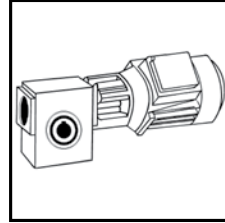

**Series BS**  
Worm gear unit

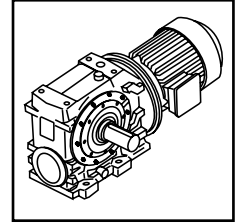

**Series C**  
Right angle drive helical worm geared motors & reducers

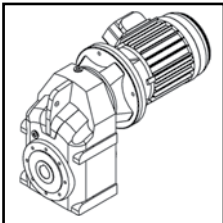

**Series F**  
Parallel shaft helical geared motors & reducers

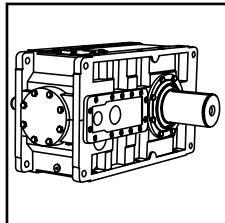

**Series G**  
Helical parallel shaft & bevel helical right angle drive gear units

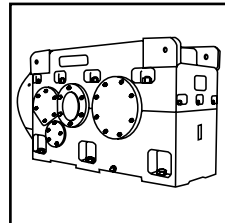

**Series H**  
Large helical parallel shaft & bevel helical right angle drive units

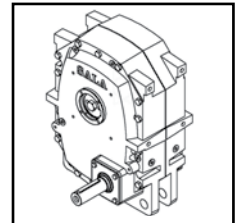

**Series J**  
Shaft mounted helical speed reducers

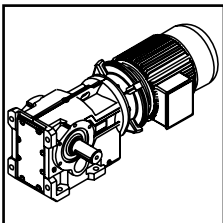

**Series K**  
Right angle helical bevel helical geared motors & reducers

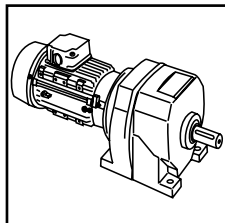

**Series M**  
In-line helical geared motors & reducers

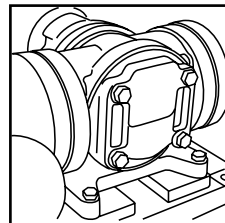

**Roloid Gear Pump**  
Lubrication and fluid transportation pump

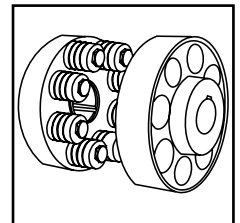

**Series X Cone Ring**  
Pin and bush elastomer coupling

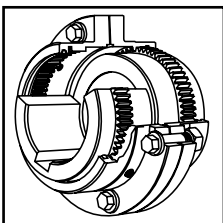

**Series X Gear**  
Torsionally rigid, high torque coupling

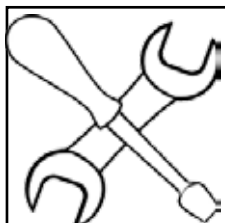

**Service & Repair**  
All brands and types

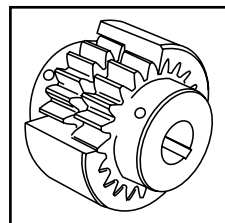

**Series X Nylon**  
Gear coupling with nylon sleeve

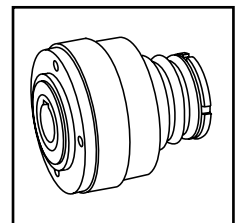

**Series X Torque Limiter**  
Overload protection device



We offer a wide range of repair services and many years experience of repairing demanding and highly critical transmissions in numerous industries.

We can create custom engineered transmission solutions of any size and configuration.

# ATEX Compliance Assured



Total compliance with the ATEX Directive safeguarding the use of industrial equipment in potentially explosive atmospheres is assured for users of our geared products.

Certification is available for standard gearboxes and geared motors with badging displaying the CE Mark and the Ex mark, name and location of the manufacturer, designation of series or type, serial number, year of manufacture, Ex symbol and equipment group/category.

ATEX directive 94/9/EC (also known as ATEX 95 or ATEX 100A) and the CE Marking Directive are enforced in all EC member states. Compliance is compulsory for designers, manufacturers or suppliers of electrical and non-electrical equipment for use in potentially explosive atmospheres created by the presence of flammable gases, vapours, mists or dusts.

Ex compliant standard gearboxes can be supplied against Groups 2 or 3 for surface industries in designated hazardous location Zones 1 and 2 for gases, vapours and mists; and in Zones 21 and 22 for dusts.



## CONTENTS PAGE

General Description _____	1
Unit Designations _____	2
Design Features _____	3 - 4
Explanation and use of Ratings and Service Factors _____	5 - 7
Selection Procedure _____	8 - 9
Lubrication _____	10
Unit Handings and Shaft Rotations _____	11 - 12
Standard Shaft Sealing Arrangements _____	13
Inputshaft Options _____	14
Outputshaft Options _____	15
Outputbore Options _____	16
<b>REDUCER</b>	
Overhung & Axial Loads on Shafts _____	19 - 20
Agitator Applications _____	21 - 22
<b>Parallel Shaft Units</b>	
Moments of Inertia _____	25
Exact Ratios _____	26
Mechanical Ratings - Input Power / Output Torque _____	27 - 31
Thermal Ratings _____	32
Dimension Sheets - Speed Reducers _____	33 - 36
Fan Cooling _____	37
<b>Right Angle Shaft Units</b>	
Moments of Inertia _____	39
Exact Ratios _____	40
Mechanical Ratings - Input Power / Output Torque _____	41 - 45
Thermal Ratings _____	46
Dimension Sheets - Speed Reducers _____	47 - 52
Fan Cooling _____	53
Hollow Output Shaft with Shrink Disc _____	54
Keyed Sleeves _____	55
Cooling Coil Connections _____	56
Backstops _____	57
Torque Arm _____	58
<b>MOTORISED</b>	
Dimension Sheets - Geared Motors _____	60 - 61
Shipping Specification _____	62

## GENERAL DESCRIPTION

### Series G

Series G gear units are available in parallel shaft helical units and right angle shaft bevel/helical units in double, triple and quadruple reduction gear stages having a maximum output torque of up to 162,000 Nm.

The modular design and construction of the Series G offers many engineering and performance benefits including a high degree of interchangeability of parts and sub assemblies. This in turn provides considerable economies of production whilst maintaining the highest standard of component integrity.

Adding to the range of power transmission geared motors this product takes advantage of our many years of accumulated design expertise together with the use of high quality materials and components. The end result is a series of speed reducing gear units offering high load carrying capacities, increased efficiency, quiet running and reliability.

### The Range Includes

- 8 sizes of units with a ratio coverage of 6.3:1 to 315:1.
- Parallel shaft helical units and Right angle bevel/helical units.

### Design Features Include

- Profile ground helical gears / hard finished spiral bevel gears.
- High level of surface finish for quiet running.
- Units can be offered in horizontal mounting positions or alternatively vertical mounting.
- Specially designed units are available for heavy duty agitator or tower applications.
- All units are also available with a hollow bore for output shaft mounting. Output bores are connected by a shrink disc or can be supplied with a keyed sleeve.
- Backstops can be fitted to all Series G units when required to operate in non-reversing drives.

*As improvements in design are being made continually this specification is not to be regarded as binding in detail and drawings and capacities are subject to alteration without notice. Certified drawings will be sent on request.*

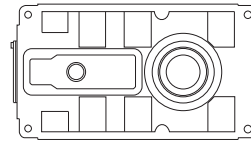

Parallel shaft unit

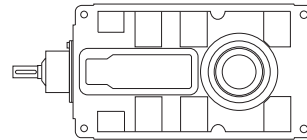

Right angle shaft unit

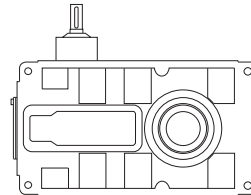

Type 'J' right angle shaft unit

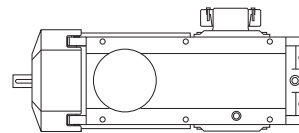

Right angle shaft unit with mechanical fan and hollow output shaft with shrink disc

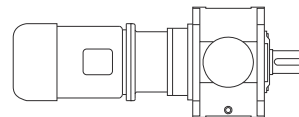

Parallel shaft unit with a lantern housing coupling and motor

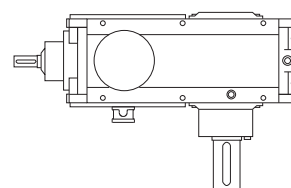

Right angle heavy duty agitator unit

# SERIES G

## UNIT DESIGNATIONS

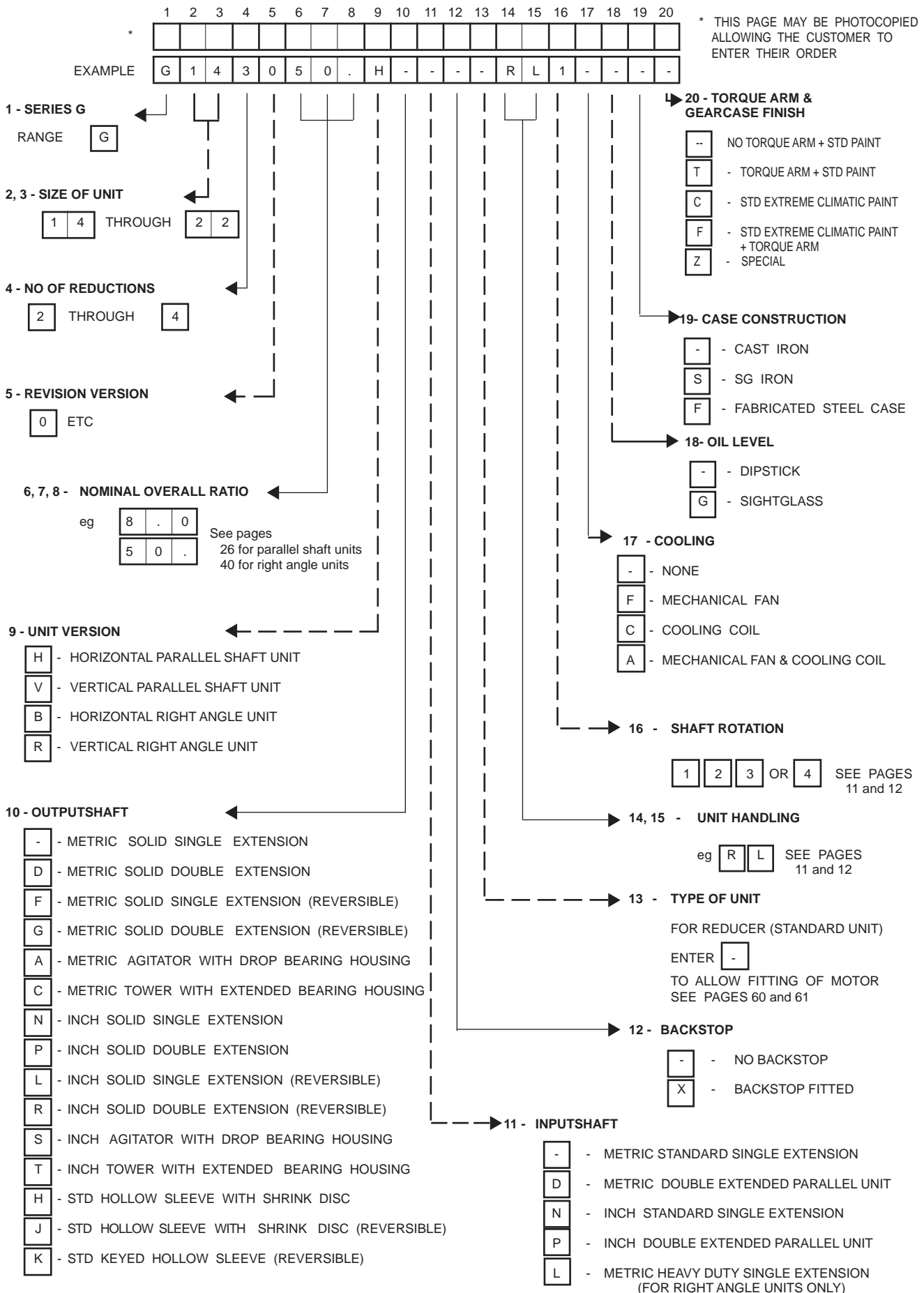

REVERSIBLE OPTION SHOULD BE SELECTED FOR ALL UNITS SUBJECT TO TORQUE REVERSALS  
(see page 5 for explanation of use and associated rating factors)

### Shaft Mounted Units

Shaft mounted units can be mounted on the driven machine shaft extension and connected to the foundation by a torque arm, supplied as an optional extra.

Additionally, unit feet are available for mounting on a baseplate with motor and coupling, the complete assembly being mounted on the driven machine shaft extension and connected to the foundation by a torque arm.

Shaft mounted units are fitted with a 'shrink disc' device to provide positive clamping on the driven machine shaft extension. It is positioned on the input side of the gear unit.

Shaft mounted units with keyed sleeves may also be supplied for fitting on to a keyed shaft.

### Motorised Gear Units

Gear units are available as standard assemblies comprising IEC standard metric (B5) flanged and NEMA 'C' motors directly mounted on the gearcase input shaft housings by adaptors. Motor and gear unit shafts are connected by flexible couplings.

### Baseplates

Standard baseplates can be supplied for units with parallel or right angle shafts. Assemblies comprise of gear units and foot mounted motors correctly aligned in manufacture and connected by our couplings. Coupling guards are fitted.

Baseplates for right angle shaft gear units are designed for use with either foot or shaft mounted arrangements, and provision is made for attaching torque arms where required.

Designs provide ample stiffness to prevent distortion under load. Full details are available from our Application Engineers.

### Backstops

Externally mounted Backstops can be fitted to all Series G gear units, when required to operate in non-reversing drives. They are located on the helical pinion shaft and have adequate capacities to deal with full rated torques. All backstops are centrifugal lift off type. Changing the direction of locking rotation is a simple operation. If required, a torque limiting backstop with controllable tension release can be fitted to all units (consult our Application Engineers).

### Preservation / Protection

Series G gear units are despatched without oil.

Prior to despatch they are test run with a rust preventative oil giving adequate protection to internal parts for a period of six months covering normal transport and covered storage.

Shaft extensions and hollow output shafts are protected with a rust inhibitor which is proof against sea water and suitable for under-cover storage up to 12 months.

Note: Where gear units are to operate in abnormal conditions, or where they are to stand for long periods without running, eg in plant installation, we must be notified so that suitable protective arrangements can be made.



### Gears

High quality alloy case hardening materials provide long life wear resistance and fatigue strength.

Profile ground single helical gears and hard finished spiral bevel gears ensure high standards of accuracy, surface finish and quiet running characteristics. Helical gears are fitted in parallel shaft units. Units with shafts at right angles incorporate spiral bevel and helical gears.

### Gearcases

Standard gearcases are of rigid cast iron construction with modern styling, special cases can be supplied as SG iron or fabricated steel.

Horizontal split case design for ease of maintenance.

Gearcase design using finite element analysis to give high strength to weight ratio.

Inspection cover provided for viewing gear contacts.

Oil level dipstick, ventilator and drain plugs are fitted.

With an option to fit an oil level sight glass.

### Gearcase Finish

Gearcase housings are shot blasted to SA 2-1/2 (or better) prior to painting.

Standard Paint System - Short oil alkyd resin/pigment semi-gloss, Colour: - RAL 5009 (Blue).

Optional Paint System for Extreme Climatic and Environmental Conditions - Two pack epoxy acrylic semi-gloss finish, Colour: - RAL 5009 (Blue).

Both paint systems are resistant to dilute acids and alkalis, oils and solvents, sea water and temperatures up to 140 Deg C.

### External Dimensions

Shaft extensions and hollow wheelshaft bores are to metric standards.

Fasteners are metric.

### Lubrication

Lubrication in most instances is by the transfer of oil by gears dipping in the sumps of gear unit bases. Where high pitch line speeds could cause churning of the lubricant. Spray lubrication is necessary where shown and complete systems can be supplied when required.

The unit oil grade and change period will be stamped on the nameplate. The change period will be 6 months for mineral oil based lubricants and 18 months for synthetic oil based lubricants. These figures assume a sump temperature of 110°C. Oil change periods can be extended for lower sump temperatures see installation and maintenance leaflet.

Units are provided with a dipstick, ventilator and drain plugs.

### Cooling

Depending on the application standard gear units are cooled by:-  
Normal heat dissipation by convection from external surfaces.  
Mechanical fan fitted to high speed shaft.  
Cooling water coil fitted in gear unit base.  
Fan and cooling coil.  
Separate oil cooler incorporated in forced lubrication system.

As improvements in design are being made continually this specification is not to be regarded as binding in detail and drawings and capacities are subject to alteration without notice. Certified drawings will be sent on request.

# SERIES G

## EXPLANATION AND USE OF RATINGS AND ASSOCIATED RATING FACTORS

Gear unit selection is made by comparing actual loads with catalogue ratings. Catalogue ratings are based on a standard set of loading conditions, whereas actual load conditions vary according to type of application. Service Factors are therefore used to calculate an equivalent load to compare with catalogue ratings. i.e. Equivalent Load = Actual Load x Service Factor

Mechanical and Thermal Service Factor must be considered:- Mechanical Service Factors Fm and Fs  
Thermal Service Factors Ft, Fd, Fh and Fv

### Mechanical ratings and service factors Fm and Fs

Mechanical ratings measure capacity in terms of life and/or strength, assuming 10 hr/day continuous running under uniform load conditions.

Catalogue ratings allow 100% overload at starting, braking or momentarily during operation up to 10 times per day.

The unit selected must therefore have a catalogue rating at least equal to half maximum overload.

Mechanical Service Factor Fm (Table 1) is used to modify the actual load according to daily operating time, and type of loading. Required mechanical power rating P(mech) = absorbed power x Fm

Load characteristics for a wide range of applications are detailed in Table 3 opposite, which are used in deciding the appropriate Service Factor Fm from Table 1.

If loading can be calculated, or accurately assessed, actual loads should be used instead modifying using Fm.

For units subject to torque reversal or frequent stop/start overloads in excess of 10 times per day, the following check should be made

$$\text{gear unit input power capacity (kW)} \geq \frac{T_m \times F_s \times n}{2 \times 9550}$$

Where Tm = motor starting torque (Nm) or rating of torque limiting device, fluid coupling etc

n = input speed (rev/min)

Fs = number of starts factor (See table 2)

For applications where high inertia loads are involved e.g. crane travel drives, slewing motion etc, or when units are to operate in extremely dusty or moist/humid atmospheres, unit selection should be referred to our Application Engineers.

**Table 1. Mechanical Service Factor (Fm)**

Prime Mover	Duration of service hours per day	Load classification-driven machine		
		Uniform	Moderate Shock	Heavy Shock
Electric motor, stream turbine or hydraulic motor	Under 3	1.00	1.00	1.50
	3 to 10	1.00	1.25	1.75
	Over 10	1.25	1.50	2.00
Multi-cylinder internal combustion engine	Under 3	1.00	1.25	1.75
	3 to 10	1.25	1.50	2.00
	Over 10	1.50	1.75	2.25
Single cylinder internal combustion engine	Under 3	1.25	1.50	2.00
	3 to 10	1.50	1.75	2.25
	Over 10	1.75	2.00	2.50

**Table 2. Number of Starts Factor (Fs)**

Start / Stops per hour (1)	Up to 1	5	10	40	60	≥200
Unidirectional	1.0	1.03	1.06	1.10	1.15	1.20
Reversing	1.4	1.45	1.50	1.55	1.60	1.70

Note: (1) Intermediate values are obtained by linear interpolation

# SERIES G

## EXPLANATION AND USE OF RATINGS AND ASSOCIATED RATING FACTORS

**Table 3**

**U = Uniform load**

**M = Moderate shock load**

**H = Heavy shock load**

**† = Refer to Application Engineering**

Driven Machine	type of load	Driven Machine	type of load	Driven Machine	type of load
<b>Agitators</b>		<b>Cranes</b>		log haul	H
pure liquids	U	main hoists	†	presses	M
liquids and solids	M	bridge travel	†	pulp machine reel	M
liquids-variable density	M	trolley travel	†	stock chest	M
<b>Blowers</b>		<b>Crusher</b>		suction roll	M
centrifugal	U	ore	H	washers and thickeners	M
lobe	M	stone	H	winders	M
vane	U	sugar	H	<b>Printing presses</b>	†
<b>Brewing and distilling</b>		<b>Dredges</b>		<b>Pullers</b>	
bottling machinery	M	cable reels	M	barge haul	H
brew kettles-continuous	M	conveyors	M	<b>Pumps</b>	
duty	M	cutter head drives	H	centrifugal	U
cookers-continuous duty	M	jig drives	H	proportioning	M
mash tubs-continuous	M	manoeuvring winches	M	reciprocating	
scale hopper-frequent	M	pumps	M	single acting; 3 or	
starts	M	screen drive	H	more cylinders	M
<b>Can filling machines</b>	M	stackers	M	double acting; 2 or	
<b>Cane knives</b>	M	utility winches	M	more cylinders	M
<b>Car dumpers</b>	H	<b>Dry dock cranes</b>		single acting; 1 or 2	
<b>Car pullers</b>	M	main hoist	†	cylinders	†
<b>Clarifiers</b>	U	auxiliary hoist	†	double acting; single	†
<b>Classifiers</b>	M	boom, luffing	†	rotary	
<b>Clay working machinery</b>		rotating, swing or slew	†	gear type	U
brick press	H	tracking, drive wheels	†	lobe, vane	U
briquette machine	H	<b>Elevators</b>		<b>Rubber and plastics industries</b>	
clay working machinery	M	bucket-uniform load	U	crackers	H
pug mill	M	bucket-heavy load	M	laboratory equipment	M
<b>Compressors</b>		bucket-continuous	U	mixed mills	H
centrifugal	U	centrifugal discharge	U	refiners	M
lobe	M	escalators	U	rubber calenders	M
reciprocating		freight	M	rubber mill-2 on line	M
multi-cylinder	M	gravity discharge	U	rubber mill-3 on line	M
single cylinder	H	man lifts	†	sheeter	M
<b>Conveyors-uniformly loaded or fed</b>		passenger	†	tire building machines	†
apron	U	<b>Fans</b>		tire and tube press	†
assembly	U	centrifugal	U	openers	
belt	U	cooling towers		tubers and strainers	M
bucket	U	induced draft	†	warming mills	M
chain	U	forced draft	†	<b>Sand muller</b>	M
flight	U	induced draft	M	<b>Sewage disposal equipment</b>	
oven	U	large, mine, etc	M	bar screens	U
screw	U	large, industrial	M	chemical feeders	U
<b>Conveyors-heavy duty not uniformly fed</b>		light, small diameter	U	collectors	U
apron	M	<b>Feeders</b>		dewatering screws	M
assembly	M	apron	M	scum breakers	M
belt	M	belt	M	slow or rapid mixers	M
bucket	M	disc	U	thickeners	M
chain	M	reciprocating	H	vacuum filters	M
flight	M	screw	M	<b>Screens</b>	
live roll	†	<b>Food industry</b>		air washing	U
oven	M	beef slicer	M	rotary-stone or gravel	M
reciprocating	H	cereal cooker	U	travelling water intake	U
screw	M	dough mixer	M	<b>Slab pushers</b>	M
shaker	H	meat grinders	M	<b>Steering gear</b>	†
		<b>Generators-not welding</b>	U	<b>Stokers</b>	U
		<b>Hammer mills</b>	H	<b>Sugar industry</b>	
		<b>Hoists</b>		cane knives	M
		heavy duty	H	crushers	M
		medium duty	M	mills	M
		skip hoist	M	<b>Textile industry</b>	
		<b>Laundry washers</b>		batchers	M
		reversing	M	calenders	M
		<b>Laundry tumblers</b>	M	cards	M
		<b>Line shafts</b>		dry cans	M
		driving processing		dryers	M
		equipment	M	dyeing machinery	M
		light	U	knitting machines	†
		other line shafts	U	looms	M
		<b>Lumber industry</b>		mangles	M
		barkers-hydraulic-		nappers	M
		mechanical	M	pads	M
		burner conveyor	M	range drives	†
		chain saw and drag saw	H	slashers	M
		chain transfer	H	soapers	M
		craneway transfer	H	spinners	M
		de-barking drum	H	tenter frames	M
		edger feed	M	washers	M
		gang feed	M	winders	M
		green chain	M	<b>Windlass</b>	†
		live rolls	H		
		log deck	H		
				log haul-incline	H
				log haul-well type	H
				log turning device	H
				main log conveyor	H
				off bearing rolls	M
				planer feed chains	M
				planer floor chains	M
				planer tilting hoist	M
				re-saw merry-go-round	
				conveyor	M
				roll cases	H
				slab conveyor	H
				small waste	
				conveyor-belt	U
				small waste	
				conveyor-chain	M
				sorting table	M
				tipple hoist conveyor	M
				tipple hoist drive	M
				transfer conveyors	M
				transfer rolls	M
				tray drive	M
				trimmer feed	M
				waste conveyor	M
				<b>Machine tools</b>	
				bending roll	M
				punch press-gear driven	H
				notching press- belt	
				driven	†
				plate planers	H
				tapping machine	H
				other machine tools	
				main drives	M
				auxiliary drives	U
				<b>Metal mills</b>	
				draw bench carriage	
				and main drive	M
				pinch, dryer and	
				scrubber rolls-reversing	†
				slitters	M
				table conveyors	
				non-reversing	
				group drives	M
				individual drives	H
				reversing	
				wire drawing and	
				flattening machine	M
				wire winding machine	M
				<b>Mill-rotary type</b>	
				<b>ball</b>	
				cement kilns	H
				dryers and coolers	H
				kilns, other than cement	H
				pebble	H
				rod	
				plain	H
				wedge bar	H
				tumbling barrels	H
				<b>Mixers</b>	
				concrete mixers	
				-continuous	M
				concrete mixers	
				-intermittent	M
				constant density	U
				variable density	M
				<b>Oil industry</b>	
				chillers	M
				oil well pumping	†
				paraffin filter press	M
				rotary kilns	M
				<b>Paper mills</b>	
				agitators, (mixers)	M
				barker-auxiliaries-	
				hydraulic	M
				barker-mechanical	H
				barking drum	H
				beater and pulper	M
				bleacher	U
				calenders	M
				calenders-super	H
				converting machine,	
				except cutters, platers	M
				conveyors	U
				couch	M
				cutters-plates	H
				cylinders	M
				dryers	M
				felt stretcher	M
				felt whipper	H
				jordans	M

# SERIES G

## EXPLANATION AND USE OF RATINGS AND ASSOCIATED RATING FACTORS

### Thermal ratings and service factors

The Thermal ratings are a measure of the gear units ability to dissipate heat. If they are exceeded the lubricant may overheat and breakdown, resulting in gear failure.

Thermal ratings are given on page 32 for parallel shaft units and page 46 for right angle shaft units. The following choices are available:

- i) No additional cooling
- ii) Unit fitted with fan cooling
- iii) Unit fitted with water cooling coil
- iv) Unit fitted with cooling coil and fan

Catalogue thermal limitations are based on the unit operating continuously in an environment with an ambient temperature equal to 25°C and in a horizontal mounting position. The thermal rating is affected by ambient temperature, duration of running per hour, altitude and operating area. To account for these varying conditions, the service factors given in tables 4, 5, 6 and 7 should be applied as follows:-

$$P_{\text{therm}} = \frac{\text{Absorbed Power}}{F_t \times F_d \times F_h \times F_v}$$

- $P_{\text{therm}}$  = Required thermal rating (kW)
- $F_t$  = Service factor for ambient temperature (see Table 4)
- $F_d$  = Service factor for intermittent duty (see Table 5)
- $F_h$  = Thermal service factor for altitude (see Table 6)
- $F_v$  = Thermal service factor for air velocity correction (operating area) (see Table 7)

**Table 4. Ambient Temperature Factor (Ft)**

Unit Type	Ambient Temperature							
	-20°C	-10°C	0°C	15°C	25°C	30°C	35°C	45°C
All Units	1.65	1.50	1.35	1.14	1.00	0.93	0.86	0.71

**Table 5. Intermittent Duty Factor (Fd)**

Unit Output Speed (Rev / min)	% Running time per hour				
	100	80	60	40	20
0 to 10	1.00	1.18	1.45	1.72	2.38
>10 to 25	1.00	1.16	1.39	1.64	2.22
>25 to 50	1.00	1.14	1.31	1.54	2.00
>50 to 100	1.00	1.08	1.19	1.33	1.64
>100 to 150	1.00	1.04	1.08	1.19	1.41
>150 to 200	1.00	1.00	1.00	1.06	1.23
>200	1.00	1.00	1.00	1.00	1.00

**Table 6. Altitude Adjustment Factor (Fh)**

Altitude (m)	Factor Fh
Sea Level	1.0
500	0.97
1000	0.93
1500	0.90
2000	0.87
3000	0.81
4000	0.75
5000	0.70

**Table 7. Ambient Air Velocity Correction Factor (Fv)**

Use  $F_v = 1.0$  For Fan Cooled Units

Operating Area	If Vv is not known use this value for Fv	Air Velocity Vv m/sec	Factor Fv If Vv is known use this formula for Fv
Small confined space (no fan)	0.86	0 - 1.4	$F_v = 0.1 V_v + 0.86$
Large indoor space (& fan cooled)	1	> 1.4 - < 6	$F_v = 0.2 V_v + 0.72$
Sheltered outdoor space (no fan)	1.3	> 2 - < 6	$F_v = 0.17 V_v + 0.9$
Outdoor space (no fan)	1.5	> 2	$F_v = 0.17 V_v + 0.9$ (max $F_v = 1.92$ )

### General

When checking thermal capacities of units, use actual load required to be transmitted, not rating of prime mover.

## SELECTION PROCEDURE

### EXAMPLE APPLICATION DETAILS

Absorbed power of driven machine = 70 kW  
 Output speed of gearbox or Input speed of machine = 65 rev/min  
 Application = Uniformly loaded belt conveyor operating in a large indoor space  
 Duration of service (hours per day) = 24hrs  
 Motor speed = 3 phase electric motor, 4 pole, 1450 rev/min  
 Mounting position = Horizontal, Right Angle Shaft  
 Ambient temperature = 35°C  
 Running time (%) = 100%  
 Altitude = Sea Level

### 1 DETERMINE RATIO OF GEARBOX REQUIRED

$$\frac{\text{Motor speed}}{\text{Gearbox output speed}} = \frac{1450}{65} = 22.31$$

Refer to exact ratios (page 40) for nearest standard ratio = 22:1

### 3 DETERMINE REQUIRED MECHANICAL OUTPUT TORQUE CAPACITY OF GEARBOX

Required mechanical = Absorbed power x Fm rating (Pmech)

$$P_{mech} = 70 \times 1.25 = 87.5 \text{ kW}$$

### 2 DETERMINE MECHANICAL SERVICE FACTOR (Fm)

Refer to Load Classification by Application, table 3, page 6

Application = Uniformly loaded belt conveyor

#### Conveyors-uniformly loaded or fed

apron	U	U = Uniform load
assembly	U	
belt	U	
bucket	U	
chain	U	

Refer to mechanical service factor (Fm), table 1, page 5

Duration of service (hours per day) = 24hrs

Prime mover	Duration of service-hrs per day	Load classification-drive	
		Uniform	Moderate Shock
Electric motor, steam turbine or hydraulic motor	Under 3	0.80	1.00
	3 to 10	1.00	1.25
	Over 10	1.25	1.50

Therefore mechanical service factor (Fm) = 1.25

### 4 DETERMINE SIZE OF GEAR BOX REQUIRED

Unit input power capacity  $\geq$  Pmech

Refer to ratings tables, Input speed = 1450rev/min, therefore refer to page 42.

NOMINAL RATIO	NOMINAL OUTPUT SPEED REV / MIN	CAPACITY	RIGHT ANGLE UNIT - SIZE			
			G14	G15	G16	G17
22.	65.9	Input Power - kW	69.2	103	185	243
		Output Torque - Nm	9550	14000	23700	35300

Mechanical input power capacity must be equal or more than required mechanical input power capacity of the gear box (Pmech). Required mechanical input power = 87.5 kW. At a 22:1 ratio, nominal output speed 65.9 a G15 unit has a mechanical input power capacity of 103 kW. Therefore the unit is acceptable.

If the unit is subject to torque reversal or frequent stop /starts the input power capacity must be checked in accordance with the formulae on page 5.

### 5 DETERMINE EXACT RATIO OF GEARBOX

Refer to exact ratios table, page 40

Nominal Ratio Column Entry	14	15	16	17
6 7 8				
2 2 .	21.775	21.541	21.756	22.894
Exact ratio =	21.541			

Go to point 6 page 9

## SELECTION PROCEDURE

### 6 DETERMINE THERMAL SERVICE FACTOR (Ft)

Refer to table 4, page 7  
Ambient temperature = 35°C

Ambient temperature °C	-20	-10	0	15	25	30	35
Factor Ft	1.65	1.50	1.35	1.14	1.00	0.93	0.86

Ft = 0.86

### 7 DETERMINE THERMAL SERVICE FACTOR (Fd)

Refer to table 5, page 7  
Unit running time per hour = 100%  
Nominal output speed (rev/min) = 65.9

Unit Output Speed (Rev / min)	% Running time per hour	
	100	80
>10 to 25	1.0	1.16
>25 to 50	1.0	1.14
>50 to 100	1.0	1.08

Fd = 1.0

### 8 DETERMINE ALTITUDE ADJUSTMENT THERMAL SERVICE FACTOR (Fh)

Refer to table 6, page 7

Altitude (m)	Factor Fh
Sea Level	1.0
500	0.97
1000	0.93

Fh = 1.0

### 9 DETERMINE AMBIENT AIR VELOCITY FACTOR (Fv)

Operating Area	If Vv is not known use this value for Fv	Air Velocity Vv m/sec	Factor Fv If Vv is known use this formula for Fv
Small confined space	0.86	0 - 1.4	$Fv = 0.1 Vv + 0.86$
Large indoor space & fan cooled	1.0	> 1.4 - < 6	$Fv = 0.2 Vv + 0.72$

Fv = 1.0

### 10 CALCULATE REQUIRED THERMAL RATING P<sub>therm</sub>

$$P_{therm} = \frac{\text{Absorbed Power (kW)}}{F_t \times F_d \times F_h \times F_v}$$

$$P_{therm} = \frac{70}{0.86 \times 1.0 \times 1.0 \times 1.0}$$

$$P_{therm} = 81.4 \text{ kW}$$

### 11 CHECK THERMAL CAPACITY

Refer to Page 46

Thermal Rating  $\geq$  P<sub>therm</sub>

#### Thermal Ratings Kw

#### Right Angle Shaft Units - Triple Reduction

Type of Cooling	Input Speed (rev/min)	Ratio	G1430	G1530	G1630
No Additional Cooling	960	12:1	62	65	107
		25:1	49	54	91
		56:1	31	37	65
Fan Cooling	1750	12:1	179	181	288
		25:1	154	161	261
		56:1	111	124	211
	1450	12:1	158	161	259
		25:1	135	142	234
		56:1	96	108	187
	1160	12:1	138	140	230
		25:1	117	123	207
		56:1	83	93	163
	960	12:1	124	126	210
		25:1	104	110	188
		56:1	73	83	147
Cooling Coil	1750	12:1	174	180	281
		25:1	149	160	255
		56:1	106	123	205

P<sub>therm</sub> = 81.4 kW  
therefore unit requires cooling.

Thermal rating for the nearest fan cooled G15 unit is

25:1 ratio = 142 Kw.

Thermal capacity is therefore acceptable.

### 12 CHECK OVERHUNG LOADS

If sprocket, gear, etc is mounted on the input or output shaft then refer to Overhung loads procedure, pages 18 TO 24

### 13 CHECK COUPLING HUB CAPACITIES

**NOTE:** It is advisable that all selections are verified by our Application Engineers.

If any of the following conditions occur then our Application Engineers **must** be consulted:-

- a) Inertia of the Driven Machine (Referred to motor speed) >1.0      b) Ambient temperature is above 50°C  
Inertia of Gear Unit plus Motor

## LUBRICATION

All Series G units are despatched without oil (a warning label is attached), and therefore filled by the client. The grade and type of oil will be stamped on the nameplate in accordance with either of the types of oil from tables 2 and 3. Recommended oils are listed in the Approved Lubrication scheme booklet. The oil change period will be as stated in the lubrication section of Design Features page 4.

The approximate quantity of oil required is given in Table 1, but the unit should always be filled to the level marked on the dipstick or any other level indicator fitted (sight glass etc). Warning: Do not overfill the unit as this can cause leakage and overheating.

Where possible run the unit without load for a short time to circulate the lubricant thoroughly, then stop the unit and recheck the oil level after allowing the unit to stand for 10 minutes and if necessary top up to the correct mark on the dipstick or any other level indicator fitted (sight glass etc).

In addition where bearings are grease packed, the greases approved are NLGI grade 2 and recommended greases are listed in the Approved Lubrication scheme booklet.

**TABLE 1 LUBRICANT QUANTITY (Litres)**

Unit Type		UNIT SIZE							
		14	15	16	17	18	19	21	22
Parallel Shaft 2 Stage	Horizontal	22	20	47	42	92	95	180	161
	Vertical	18	18	40	37	80	85	140	150
Parallel Shaft 3 Stage	Horizontal	21	19	46	41	91	94	185	175
	Vertical	18	18	40	37	80	85	140	155
Parallel Shaft 4 Stage	Horizontal	21	19	46	41	91	94	185	175
	Vertical	18	18	40	37	80	85	140	155
Right Angle 3 Stage	Horizontal	21	19	47	42	92	95	185	175
	Vertical	20	20	43	39	87	92	140	170
Right Angle 4 Stage	Horizontal	-	-	48	43	94	96	190	175
	Vertical	-	-	45	39	89	89	140	185

**TABLE 2 OIL GRADES**

EP Mineral Oil (type E)

LUBRICANT	AMBIENT TEMPERATURE RANGE		
	-5°C to 20°C	0°C to 35°C	20°C to 50°C
Oil Grade	5E (VG 220)	6E (VG 320)	7E (VG 460)

**TABLE 3 OIL GRADES**

Polyalphaolefin based Synthetic (type H)

LUBRICANT	AMBIENT TEMPERATURE RANGE	
	-30°C to 35°C	20°C to 50°C
Oil Grade	5H (VG 220)	6H (VG 320)

# SERIES G

## UNIT HANDINGS & SHAFT ROTATIONS PARALLEL SHAFT UNITS

### Column 14 Entry - Output Shaft Positions

L SINGLE EXTENSION ON LEFT		R SINGLE EXTENSION ON RIGHT		D DOUBLE EXTENSION	
Horizontal	Vertical	Horizontal	Vertical	Horizontal (Not applicable on vertical units)	

Note: for shaft mounted units driven machine side (opposite to shrink disc) is assumed as extension side.

### Column 16 Entry - Shaft Rotations

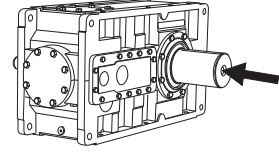

Rotation directions are defined as viewed from output shaft end\*\* (This side if double extended or keyed hollow sleeve)

\*\* Driven machine side for shaft mounted units, opposite side to shrink disc.

### Column 15 Entry - Input Shaft Positions

L SINGLE EXTENSION ON LEFT		R SINGLE EXTENSION ON RIGHT		D DOUBLE EXTENSION	
Horizontal	Vertical	Horizontal (Not applicable on vertical units)	Vertical	Horizontal (Not applicable on vertical units)	

Rotation		Parallel Shaft	
Outputshaft	Inputshaft	2 Stage & 4 Stage	3 Stage
Clockwise	Clockwise	<b>1 (std)</b>	n/a
Anticlockwise	Anticlockwise	2	n/a
Clockwise	Anticlockwise	n/a	<b>1 (std)</b>
Anticlockwise	Clockwise	n/a	2

All units are rotation reversible, except when fitted with a backstop (anti-runback device).

(std) if no rotation is entered rotation will be assumed as standard build.

<b>Double &amp; Quadruple Reduction</b>	<b>Horizontal Mounting</b>	<div style="display: flex; justify-content: space-around;"> <div style="text-align: center;">L R 1 </div> <div style="text-align: center;">R R 1 </div> <div style="text-align: center;">D R 1 </div> <div style="text-align: center;">R L 1 </div> <div style="text-align: center;">L L 1 </div> </div> <div style="display: flex; justify-content: space-around; margin-top: 10px;"> <div style="text-align: center;">D L 1 </div> <div style="text-align: center;">L D 1 </div> <div style="text-align: center;">R D 1 </div> <div style="text-align: center;">D D 1 </div> </div>
	<b>Vertical Mounting</b>	<div style="display: flex; justify-content: space-around;"> <div style="text-align: center;">R L 1 </div> <div style="text-align: center;">L L 1 </div> </div>
<b>Triple Reduction</b>	<b>Horizontal Mounting</b>	<div style="display: flex; justify-content: space-around;"> <div style="text-align: center;">L R 1 </div> <div style="text-align: center;">R R 1 </div> <div style="text-align: center;">D R 1 </div> <div style="text-align: center;">R L 1 </div> <div style="text-align: center;">L L 1 </div> </div> <div style="display: flex; justify-content: space-around; margin-top: 10px;"> <div style="text-align: center;">D L 1 </div> <div style="text-align: center;">L D 1 </div> <div style="text-align: center;">R D 1 </div> <div style="text-align: center;">D D 1 </div> </div>
	<b>Vertical Mounting</b>	<div style="display: flex; justify-content: space-around;"> <div style="text-align: center;">R L 1 </div> <div style="text-align: center;">L L 1 </div> </div>

Note: parallel shaft unit handings **R R** or **L L** are subject to a reduction in external overhung load capacities



# SERIES G

## UNIT HANDINGS & SHAFT ROTATIONS

### RIGHT ANGLE SHAFT UNITS

#### Column 14 Entry - Output Shaft Positions

L SINGLE EXTENSION ON LEFT		R SINGLE EXTENSION ON RIGHT		D DOUBLE EXTENSION	
Horizontal	Vertical	Horizontal	Vertical	Horizontal (Not applicable on vertical units)	

Note: for shaft mounted units driven machine side (opposite to shrink disc) is assumed as extension side.

#### Column 16 Entry - Shaft Rotations

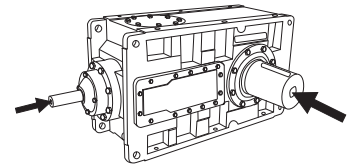

Rotation directions are defined as viewed from output shaft end\*\* (This side if double extended or keyed hollow sleeve)

\*\* Driven machine side for shaft mounted units, opposite side to shrink disc.

#### Column 15 Entry - Input Shaft Positions

B STANDARD RIGHT ANGLE EXTENSION		J RIGHT ANGLE UNIT TYPE J	
Horizontal	Vertical	Horizontal	Vertical

Note: Only available for ratios:  
 G14, G16, G18 Units - Ratios 22 to 63  
 G15, G17, G19, G22 Units - Ratios 28 to 80  
 G21 Units - Ratios 25 to 71

Rotation		Right Angle Shafts
Outputshaft	Inputshaft	3 Stage & 4 Stage
Clockwise	Clockwise	1 (std)
Anticlockwise	Anticlockwise	2
Clockwise	Anticlockwise	3 *
Anticlockwise	Clockwise	4 *

All units are rotation reversible, except when fitted with a backstop (anti-runback device).

(std) if no rotation is entered rotation will be assumed as standard build.

<b>Right Angle Shafts - Triple &amp; Quadruple Reduction</b>	<b>Horizontal Mounting</b>	L B 1 	R B 1 	D B 1 
	<b>Vertical Mounting</b>	R B 1 	L B 1 	
<b>Type J Shafts - Triple Reduction</b>	<b>Horizontal Mounting</b>	L J 1 	R J 1 	D J 1 
	<b>Vertical Mounting</b>	R J 1 	L J 1 	

Note: For units fitted with a backstop please see page 58 for backstop position.

# SERIES G

## STANDARD SHAFT SEALING ARRANGEMENTS

**Right Angle Unit Input Shaft**

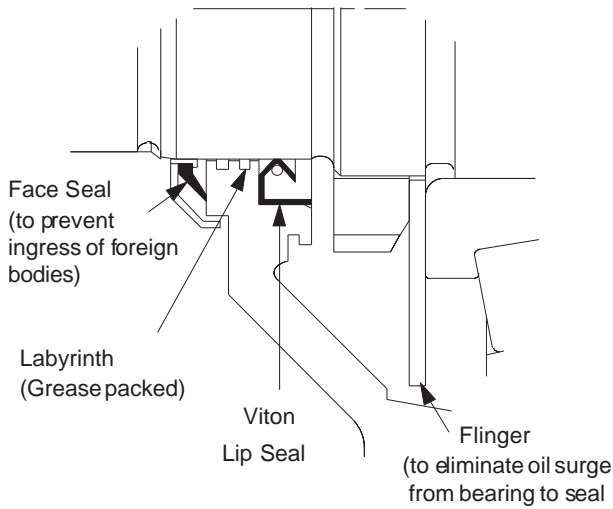

**Parallel Unit Input Shaft**

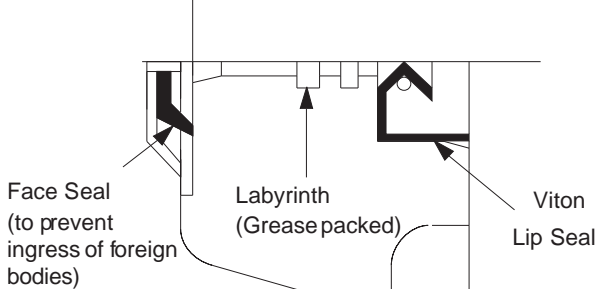

**G21 & G22 Units**

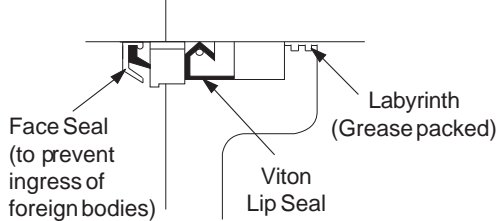

**Standard Unit Output Shaft**

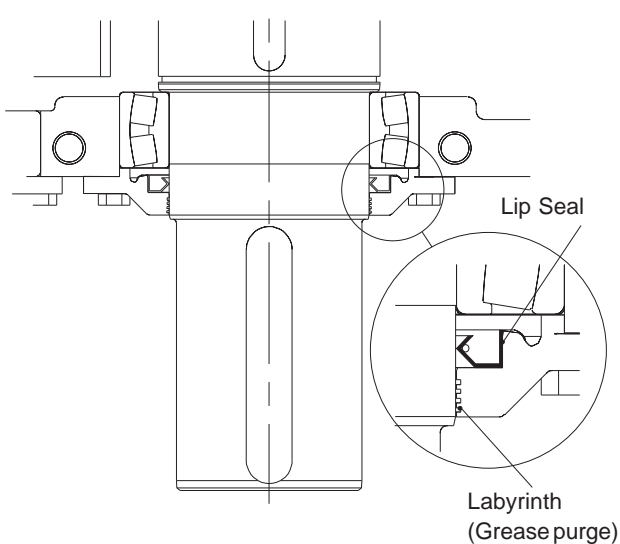

**Heavy Duty Agitator Unit Output Shaft**

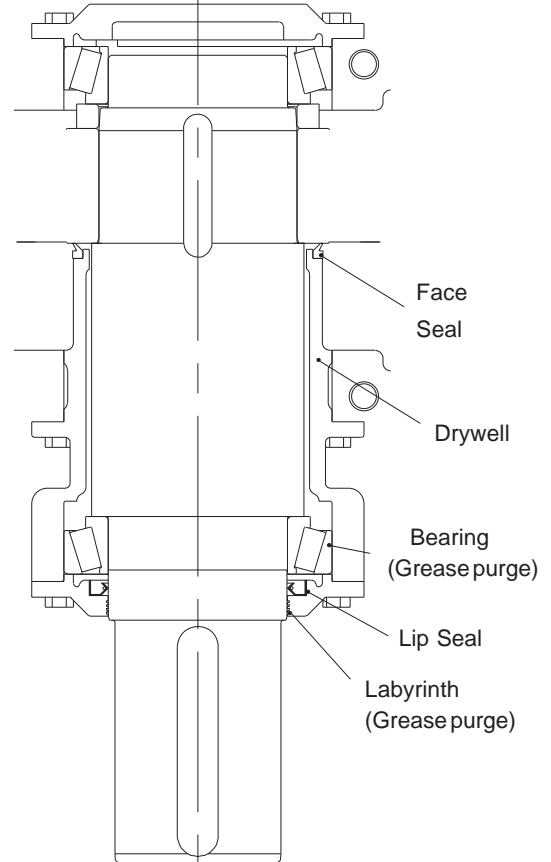

**Heavy Duty Tower Unit Output Shaft**

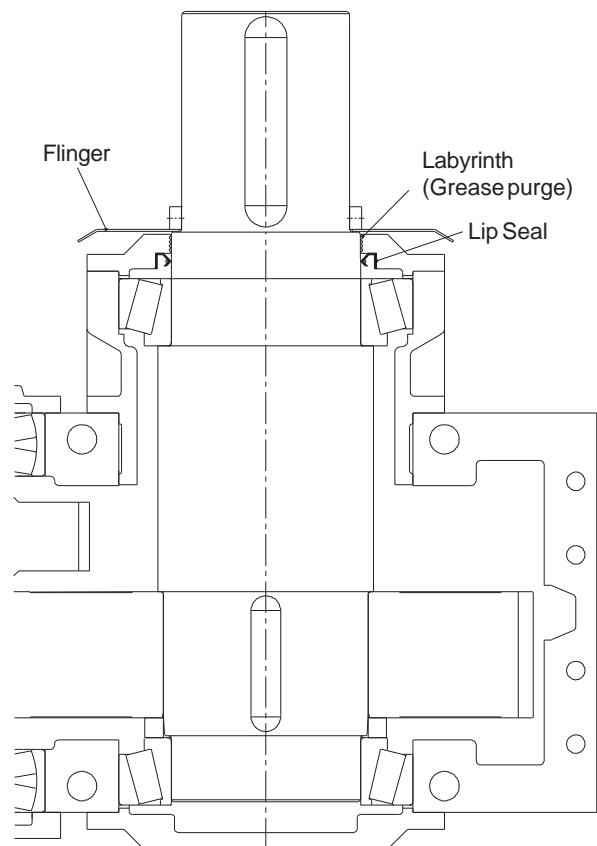

# SERIES G

## INPUTSHAFT OPTIONS

### INPUTSHAFT OPTIONS

\* Inch shaft has an open ended keyway, therefore no 'C' dimension is required.

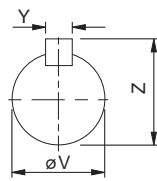
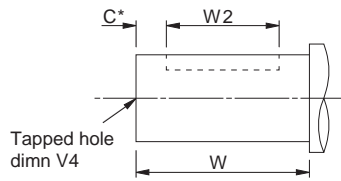

### Column 11 Entry

Metric

Single

Double

HD

Inch

Single

Double

### Parallel Shaft Units

SIZE OF UNIT	TYPE OF INPUTSHAFT	NO OF REDUCTIONS	DIMENSIONS IN MM (Inch Shaft in Inches)						
			C*	øV	V4	W	W2	Y	Z
14 AND 15	Standard Metric	2 Stage	3	50.018 50.002	M16 x 36	138	130	14	53.5
		3 and 4 Stage	3	35.018 35.002	M12 x 25	99	90	10	38
16 AND 17	Standard Metric	2 Stage	3	60.03 60.011	M20 x 43	148	140	18	64
		3 and 4 Stage	3	45.018 45.002	M16 x 36	118	110	14	48.5
18 AND 19	Standard Metric	2 Stage	3	85.035 85.013	M24 x 52	190	180	22	90
		3 and 4 Stage	3	60.03 60.011	M20 x 43	150	140	18	64
21 AND 22	Standard Metric	2 Stage	3	110.035 110.013	M30 x 63	210	200	28	116
		3 and 4 Stage	3	80.03 80.011	M20 x 43	190	180	22	85
14 AND 15	Inch	2 Stage	-	1.8750" 1.8740"	5/8" UNF x 1.25 deep	5.31"	4.13"	0.500"	2.10"
		3 and 4 Stage	-	1.3750" 1.3745"	1/2" UNF x 1 deep	3.74"	3.00"	0.3125"	1.51"
16 AND 17	Inch	2 Stage	-	2.2500" 2.2490"	3/4" UNF x 1.62 deep	5.71"	4.13"	0.500"	2.47"
		3 and 4 Stage	-	1.7500" 1.7490"	5/8" UNF x 1.25 deep	4.53"	4.13"	0.375"	1.92"
18 AND 19	Inch	2 Stage	-	3.2500" 3.2490"	1" UNF x 2 deep	7.48"	5.88"	0.750"	3.58"
		3 and 4 Stage	-	2.2500" 2.2490"	3/4" UNF x 1.62 deep	5.71"	4.13"	0.500"	2.47"
21 AND 22	Inch	2 Stage	-	4.2500" 4.2490"	1" UNF x 2 deep	8.27"	7.5"	1.000"	4.69"
		3 and 4 Stage	-	3.0000" 2.9990"	3/4" UNF x 1.62 deep	7.48"	6.50"	0.750"	3.33"

### Right Angle Shaft Units

SIZE OF UNIT	TYPE OF INPUTSHAFT	NO OF REDUCTIONS	DIMENSIONS IN MM (Inch Shaft in Inches)						
			C*	øV	V4	W	W2	Y	Z
14 AND 15	Standard Metric	3 Stage	3	38.018 / 38.002	M12 x 32	100	90	10	41
	HD Metric			50.018 / 50.002				14	53.5
16 AND 17	Standard Metric	3 Stage	3	50.018 / 50.002	M16 x 36	140	130	14	53.5
	HD Metric			60.030 / 60.011				18	64
	Standard Metric	4 Stage	3	38.018 / 38.002	M12 x 32	100	90	10	41
	HD Metric			50.018 / 50.002				14	53.5
18 AND 19	Standard Metric	3 Stage	3	75.011 / 75.030	M20 x 43	160	150	20	79.5
	HD Metric			90.035 / 90.013				25	95
	Standard Metric	4 Stage	3	50.018 / 50.002	M16 x 36	140	130	14	53.5
	HD Metric			60.030 / 60.011				18	64
21 AND 22	Standard Metric	3 Stage	3	100.035 100.013	M24 x 52	210	200	28	106
		4 Stage	3	75.03 75.011	M20 x 43	160	150	20	79.5

14 AND 15	Inch	3 Stage	-	1.5000" 1.4995"	5/8" UNF x 1.25 deep	3.94"	3.44"	0.375"	1.66"
16 AND 17	Inch	3 Stage	-	1.8750" 1.8740"	5/8" UNF x 1.25 deep	5.51"	4.13"	0.500"	2.10"
	Inch	4 Stage	-	1.5000" 1.4995"	5/8" UNF x 1.25 deep	3.94"	3.44"	0.375"	1.66"
18 AND 19	Inch	3 Stage	-	3.0000" 2.9990"	3/4" UNF x 1.62 deep	6.30"	5.25"	0.750"	3.33"
	Inch	4 Stage	-	1.8750" 1.8740"	5/8" UNF x 1.25 deep	5.51"	4.13"	0.500"	2.10"
21 AND 22	Inch	3 Stage	-	4.0000" 3.9990"	1" UNF x 2 deep	8.27"	7.5"	1.00"	4.44"
	Inch	4 Stage	-	3.0000" 2.9990"	3/4" UNF x 1.62 deep	6.30"	5.25"	0.750"	3.33"

# SERIES G

## OUTPUTSHAFT OPTIONS

### OUTPUTSHAFT OPTIONS

\* Inch shaft has an open ended keyway, therefore no 'C' dimension is required.

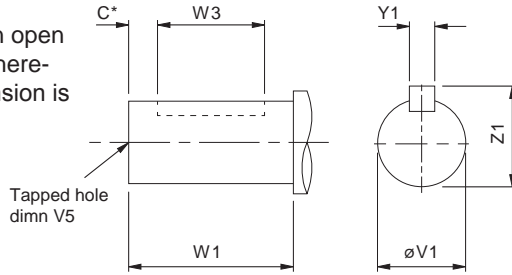

### Column 10 Entry

#### Metric

Single  -  
 Double  D  
 Agitator  A Tower  C

### Column 10 Entry

#### Inch

Single  N  
 Double  P  
 Agitator  S Tower  C

SIZE OF UNIT	TYPE OF OUTPUTSHAFT	DIMENSIONS IN MM (Inch Shaft in Inches)						
		C*	ØV1	V5	W1	W3	Y1	Z1
14	Standard Single	5	110.035	M30 x 3.5 63 deep	180	170	28	116
	Standard Double							
	Standard Agitator / Tower							
15	Standard Single	5	130.04	M30 x 3.5 63 deep	190	180	32	137
	Standard Double							
	Standard Agitator / Tower							
16	Standard Single	5	145.04	M42 x 4.5 81 deep	230	220	36	153
	Standard Double							
	Standard Agitator / Tower							
17	Standard Single	5	170.04	M42 x 4.5 81 deep	250	240	40	179
	Standard Double							
	Standard Agitator / Tower							
18	Standard Single	5	190.046	M42 x 4.5 81 deep	300	290	45	200
	Standard Double							
	Standard Agitator / Tower							
19	Standard Single	5	210.046	M42 x 4.5 81 deep	350	340	50	221
	Standard Double							
	Standard Agitator / Tower							
21	Standard Single	5	220.046	M42 x 4.5 81 deep	350	340	50	231
	Standard Double							
	Standard Agitator / Tower							
22	Standard Single	5	240.046	M42 x 4.5 81 deep	380	340	56	252
	Standard Double							
	Standard Agitator / Tower							

14	Inch Single	-	4.500"	1" UNF x 2" deep	7.09"	6.50"	1.00"	4.94"
	Inch Double							
	Inch Agitator / Tower							
15	Inch Single	-	5.000"	1" UNF x 2" deep	7.48"	7.13"	1.25"	5.55"
	Inch Double							
	Inch Agitator / Tower							
16	Inch Single	-	6.000"	1.25" UNF x 2.5" deep	9.06"	8.75"	1.50"	6.66"
	Inch Double							
	Inch Agitator / Tower							
17	Inch Single	-	6.750"	1.25" UNF x 2.5" deep	9.84"	9.38"	1.75"	7.39"
	Inch Double							
	Inch Agitator / Tower							
18	Inch Single	-	7.500"	1.5" UNF x 3 deep	11.81"	11.38"	1.75"	8.15"
	Inch Double							
	Inch Agitator / Tower							
19	Inch Single	-	8.250"	1.5" UNF x 3 deep	13.78"	13.00"	2.00"	8.88"
	Inch Double							
	Inch Agitator / Tower							
21	Inch Single	-	8.500"	1.5" UNF x 3 deep	13.78"	13.00"	2.00"	9.13"
	Inch Double							
	Inch Agitator / Tower							
22	Inch Single	-	9.250"	1.5" UNF x 3 deep	14.96"	14.25"	2.50"	9.95"
	Inch Double							
	Inch Agitator / Tower							

## OUTPUTBORE OPTIONS

### OUTPUTBORE OPTIONS

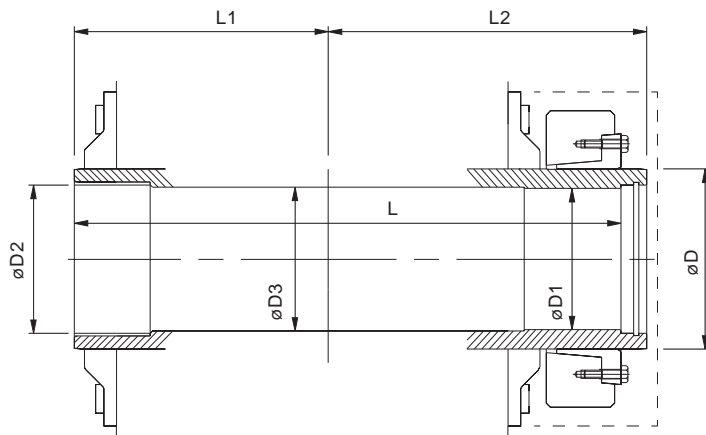

**Column 10 Entry \***

**Metric**

With Shrink Disc H

SIZE OF UNIT	TYPE OF OUTPUTBORE	DIMENSIONS IN MM (Inch Bore in Inches)						
		ØD	ØD1	ØD2	ØD3	L	L1	L2
14	Standard with Shrink Disc	120	95.035 95.000	100.087 100.000	96	415	180	255
15	Standard with Shrink Disc	140	110.035 110.000	115.087 115.000	111	420	180	260
16	Standard with Shrink Disc	160	125.040 125.000	130.100 130.000	126	533	230	325
17	Standard with Shrink Disc	180	145.040 145.000	150.100 150.000	147	548	230	340
18	Standard with Shrink Disc	200	160.040 160.000	170.100 170.000	162	688	300	410
19	Standard with Shrink Disc	220	170.040 170.000	180.100 180.000	172	708	300	430
21	Standard with Shrink Disc	260	210.046 210.000	220.100 220.000	212	824	350	500
22	Standard with Shrink Disc	280	230.046 230.000	240.100 240.000	232	839	350	515

\* Please see pages 55 & 56 for details of the hollow output shaft with Kibo bush



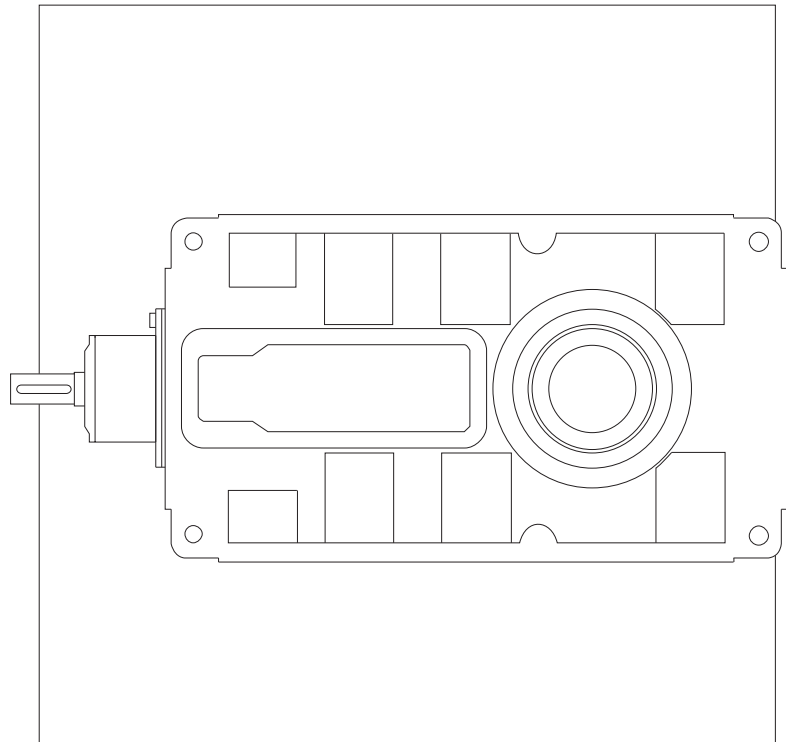

**REDUCER**  
**SERIES G**

# SERIES G

## OVERHUNG & AXIAL LOADS ON SHAFTS

### Maximum permissible overhung loads

When a sprocket, gear etc. is mounted on the shaft a calculation, as below, must be made to determine the overhung load on the shaft, and the results compared to the maximum permissible overhung loads tabulated. Overhung loads can be reduced by increasing the diameter of the sprocket, gear, etc. If the maximum permissible overhung load is exceeded, the sprocket, gear, etc. should be mounted on a separate shaft, flexibly coupled and supported in its own bearings, or the gear unit shaft should be extended to run in an outboard bearing. Alternatively, a larger gear is often a less expensive solution.

Permissible overhung loads vary according to the direction of rotation. The values tabulated are for the most unfavourable direction with the unit transmitting full rated power and the load P applied midway along the shaft extension. Hence they can sometimes be increased for a more favourable direction of rotation, or if the power transmitted is less than the rated capacity of the gear unit, or if the load is applied nearer to the gear unit case. Refer to our Application Engineers for further details. In any event, the sprocket, gear etc. should be positioned as close as possible to the gear unit case in order to reduce bearing loads and shaft stresses, and to prolong life.

All units will accept 100% momentary overload on stated capacities.

### Overhung load (Newtons)

$$P = \frac{\text{kW} \times 9,500,000 \times K}{N \times R}$$

where

- P = equivalent overhung load (Newtons)
- kW = power transmitted by the shaft (kilowatts)
- N = speed of shaft (rev/min)
- R = pitch radius of sprocket, etc. (mm)
- K = factor

### Overhung member K (factor)

Chain sprocket*	1.00
Spur or helical pinion	1.25
Vee belt sheave	1.50
Flat belt pulley	2.00

\* If multistrand chain drives are equally loaded and the outer strand is further than dimension A output or B input, refer to our Application Engineers.

Note: 1 Newton = 0.10197 kg = 0.2248 lbs.

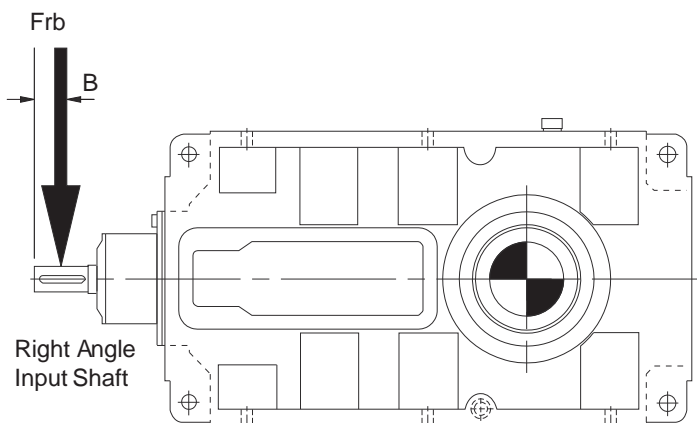
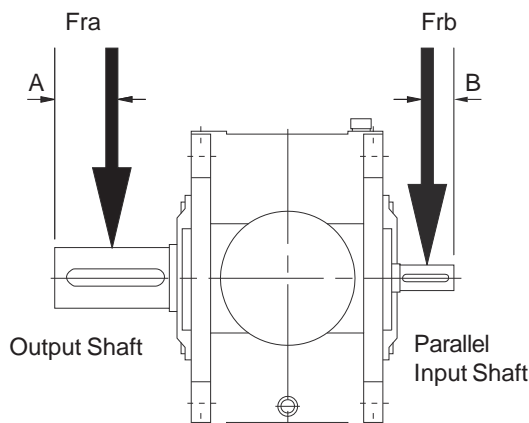

### Output Shaft - Distance 'A'

(midway along the shaft extension)

Size of unit	Dimension A(mm)
G14	90
G15	95
G16	115
G17	125
G18	150
G19	175
G21	175
G22	190

### Input Shaft - Distance 'B'

(midway along the shaft extension)

Size of unit	Parallel Shaft Unit		Right Angle Shaft Unit	
	2 Stage	3 & 4 Stage	3 Stage	4 Stage
G14 and G15	67.5	47.5	50	-
G16 and G17	72.5	57.5	70	50
G18 and G19	95	72.5	80	70
G21 and G22	105	95	105	80

### Axial Thrust Capacities (Newtons)

Permissible axial thrust capacities vary according to the direction of rotation and the direction of thrust, towards or away from the unit. The values tabulated are for the most unfavourable direction and hence can sometimes be increased. Similarly they can sometimes be increased if the power transmitted is less than the rated capacity of the gear unit.

Thrust capacities tabulated refer to outputshafts, and are calculated without any overhung loads being applied. In cases where combined axial thrusts and overhung loads are to be applied, refer to our Application Engineers.



# SERIES G

## OVERHUNG & AXIAL LOADS ON SHAFTS

### OVERHUNG LOADS (Fra) ON OUTPUTSHAFT (KN)

Parallel Shaft Units                      Handings:      LR, RL, DL and DR  
 Right Angle Shaft Units                All handings with preferred shaft rotations

Shaft Speed (Rev/min)	Unit Size							
	14	15	16	17	18	19	21	22
< 240	25	40	43	82	85	116	130	160
< 180	27	43	46	82	87	116	130	160
< 130	29	47	49	82	90	116	130	160
< 90	32	50	52	82	95	116	130	160
< 45	34	55	55	82	110	116	197	197
< 20	31	55	55	82	116	116	275	275

### OVERHUNG LOADS (Frb) ON OUTPUTSHAFT (KN)

Parallel Shaft Units                      Handings:      LL and RR  
 Right Angle Shaft Units                All handings with non-preferred shaft rotations

Shaft Speed (Rev/min)	Unit Size							
	14	15	16	17	18	19	21	22
< 240	25	32	28	60	60	80	80	80
< 180	27	35	29	60	61	80	80	80
< 130	29	37	31	60	63	80	80	80
< 90	32	40	31	60	68	80	80	80
< 45	34	45	31	60	80	80	130	130
< 20	31	45	31	60	80	80	250	250

### AXIAL THRUST ON OUTPUTSHAFT (KN)

Shaft Speed (Rev/min)	Unit Size							
	14	15	16	17	18	19	21	22
< 240	5.0	8.5	8.0	25	16	26	26	36
< 180	5.1	8.6	8.5	25	17	27	27	36
< 130	5.3	9.9	9.5	27	18	30	27	36
< 90	6.2	12	10	29	19	34	27	36
< 45	11	20	15	40	36	45	37	37
< 20	19	32	28	65	65	65	80	87

### OVERHUNG LOADS (Frb) ON INPUTSHAFT (KN)

Unit Type		Unit Size							
		14	15	16	17	18	19	21	22
Parallel Shaft	2 Stage	15	15	22	22	39	39	70	70
	3 and 4 Stage	6.9	6.9	9.1	9.1	16	16	25	25
Right Angle	2 Stage	11	11	16	16	41	41	56	56
	3 and 4 Stage	-	-	11	11	16	16	41	41

# SERIES G

## AGITATOR APPLICATIONS

### BENDING MOMENT CAPACITY

To calculate the Bending Moment on the gearbox output shaft using the method recommended in The Engineering Equipment Users' Association Handbook No. 9:-

$$\text{Bending Moment} = \frac{\text{Absorbed Power (kW)} \times 9.5 \times L}{\text{Shaft Speed} \times 0.75 R} = \text{kNm}$$

The above information is given for guidance. When more precise bending moment values are available they should be used.

Check the Bending Moment Capacity of the Gearbox  
Agitator units are suitable for supporting a paddle directly coupled to the gearbox output shaft and for accepting the bending moments and axial thrusts generated from the forces at the paddle. Agitator type units have an extended bearing span and taper bearings to accept higher loads than the standard unit.

Check the Bending Moment Capacity limited by shaft stress, using Table 2.

Check the Bending Moment Capacity limited by bearing life, using Table 3.

Note: Bearing Capacities are based on 10,000 hours, L10 life. For other bearing lives multiply the values in Table 3 by the factors in Table 1.

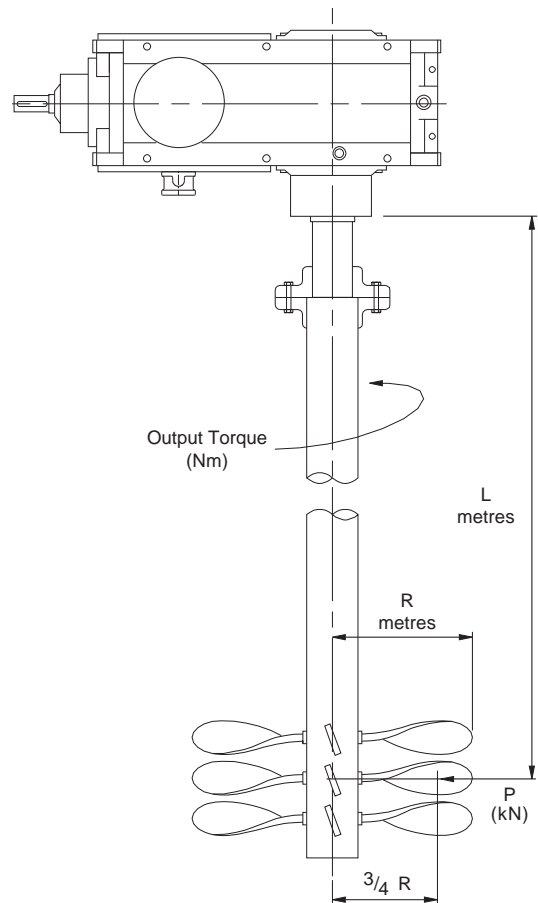

**Table 1 Bearing Life Factors ( $F_b$ )**

	Required Life (hours)				
	5000	10000	25000	50000	100000
Factor	1.23	1	0.76	0.62	0.50
For intermediate values					
$F_b = \left( \frac{10000}{\text{Required Life (hours)}} \right)^{0.3}$					

**Table 2 Bending Moment Capacity (kNm)**

Allowable Bending Moment at output shaft lower bearing, limited by SHAFT STRESS

Unit Type	Unit Size							
	14	15	16	17	18	19	21	22
Agitator Units	11.2	17.3	24.2	37.3	50	68	102	**

**Table 3 Bending Moment Capacity (kNm)**

Allowable Bending Moment on output shaft bearings, limited by BEARING LIFE (10,000 hrs L10)\*

Unit Type	Output Speed rev/min	Unit Size							
		14	15	16	17	18	19	21	22
Agitator Units	< 240	5.9	10.9	11.5	25.7	26.9	36.8	40	**
	< 180	7.4	12.9	14.5	30.1	33.7	45	53	
	< 130	10.6	16.8	21.2	38.9	48.8	61	84	
	< 90	11.5	18.4	22.9	42.6	53	68	91	
	< 45	16.6	25.2	33.3	55	73	89	133	
	< 20	24.1	32.9	46.7	71	97	117	176	

\* For other lives multiply values by the factors in table 1

\*\* Consult Application Engineering

# SERIES G

## AGITATOR APPLICATIONS

### AXIAL THRUST LOADS

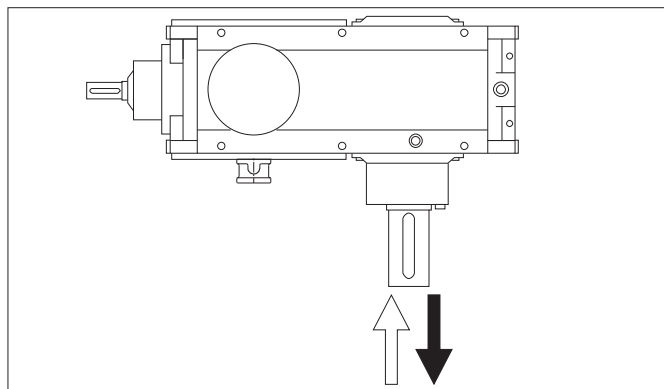

**Table 4 Axial thrust capacity (kN)**

Allowable thrust on output shaft, limited by COVER BOLT STRESS

Unit Type	Unit Size							
	14	15	16	17	18	19	21	22
Agitator Units	30	40	55	65	65	65	150	**

Note: The values in table 4 are calculated for the most adverse direction of rotation. For the opposite rotation they can be increased. Consult our Application Engineers for an analysis where necessary.

**Table 5 Axial thrust capacity (kN)**

Allowable thrust on output shaft, limited by BEARING LIFE (10,000 hrs L10)\*

Direction Of Thrust	Unit Type	Output Speed rev/min	Unit Size							
			14	15	16	17	18	19	21	22
↑	Agitator Units	< 240	14	26	23	51	40	55	56	**
		< 180	14	27	24	52	41	56	58	
		< 130	15	28	25	52	41	57	58	
		< 90	16	30	28	57	46	63	66	
		< 45	26	43	45	81	75	97	110	
		< 20	40	63	70	116	115	146	175	
↓	Agitator Units	< 240	10	22	17	44	31	45	40	**
		< 180	11	23	18	45	32	46	41	
		< 130	11	24	18	46	32	47	41	
		< 90	13	25	21	50	37	53	50	
		< 45	23	39	38	74	65	86	93	
		< 20	36	59	64	110	106	135	157	

\* For other lives multiply values by the factors in table 1 page 21.

Note: Values are based on the most unfavourable directions of rotation. Higher values may be permitted after analysis by our Application Engineers.



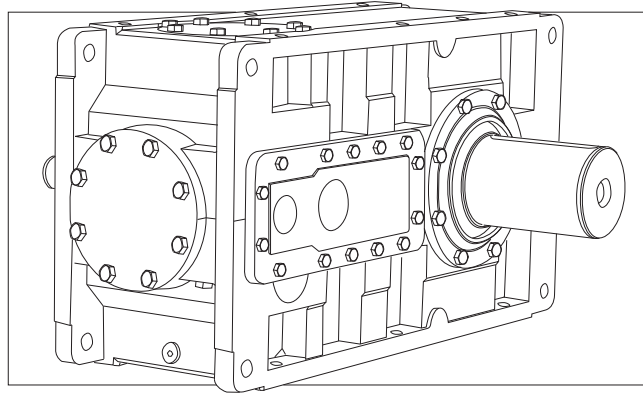

## PARALLEL SHAFT UNITS

<u>Contents</u>	<u>Page No</u>
Moments of Inertia _____	25
Exact Ratios _____	26
Mechanical Ratings - Input Power / Output Torque _____	27 - 31
Thermal Ratings _____	32
Dimension Sheets - Speed Reducers _____	33 - 37

# SERIES G

## MOMENTS OF INERTIA PARALLEL SHAFT UNITS

### MOMENTS OF INERTIA (Kg cm<sup>2</sup>) Referred to Input Shaft

#### PARALLEL SHAFT UNITS - without fans

NOMINAL RATIO COLUMN ENTRY	PARALLEL SHAFT UNITS - SIZE								
	G14	G15	G16	G17	G18	G19	G21	G22	
6.3	410	-	1420	-	6670	-	-	-	DOUBLE REDUCTION
7.1	335	-	1320	-	5760	-	23000	-	
8.0	295	485	1140	1765	4645	7960	20000	25190	
9.0	255	395	975	1620	4010	6860	17500	21900	
10.	225	345	835	1400	3735	5490	15200	18800	
11.	195	300	700	1165	3230	4685	12900	16400	
12.	170	260	585	985	2500	4310	11300	13900	
14.	145	220	485	825	2335	3685	9590	12000	
16.	125	190	445	690	1945	2860	8050	10200	
18.	105	165	415	565	1730	2610	7490	8480	
20.	98	135	380	505	1665	2150	6630	7860	TRIPLE REDUCTION
22.	90	115	350	460	1530	1910	6130	6910	
25.	85	105	320	420	1345	1810	5650	6360	
28.	79	97	296	380	1305	1650	5265	5830	
32.	73	89	292	345	1200	1430	4935	5400	
36.	45	83	150	315	610	1375	4765	5040	
40.	39	77	141	310	595	1250	2395	4850	
45.	37	43	133	165	560	655	2270	2470	
50.	35	41	126	150	515	630	2150	2330	
56.	34	39	120	140	505	590	2050	2190	
63.	33	37	118	135	475	535	1970	2090	QUADRUPLE REDUCTION
71.	31	35	112	125	435	520	1925	1990	
80.	31	34	108	122	430	490	1670	1950	
90.	30	32	107	115	415	445	1625	1825	
100	30	31	92	111	365	435	1600	170	
112	29	31	91	110	360	425	1300	1750	
125	29	30	90	95	350	365	1280	1450	
140	18	30	57	92	250	360	1270	1420	
160	18	29	53	91	225	355	840	1410	
180	18	18	52	60	220	250	730	960	
200	18	18	52	53	220	225	720	840	
225	-	18	-	52	-	220	715	835	
250	-	18	-	52	-	220	-	830	

#### PARALLEL SHAFT UNITS - with fans

If fan cooling is required the inertia of the fan must be added to the table above.

#### MOMENTS OF INERTIA of fans (Kg cm<sup>2</sup>)

	G14/G15	G16/G17	G18/G19	G21
DOUBLE REDUCTION	284	739	2365	4906
TRIPLE REDUCTION	N/A	284	739	2365

$$GD^2 \text{ (Kg cm}^2\text{)} = 4 \times \text{Moment of Inertia (Kg cm}^2\text{)}$$

# SERIES G

## EXACT RATIOS

### PARALLEL SHAFT UNITS

#### EXACT RATIOS - PARALLEL SHAFT UNITS

##### Double Reduction

Nominal Ratio Column Entry	UNIT - SIZE								
	6 7 8	G14	G15	G16	G17	G18	G19	G21	G22
6 . 3		6.1	-	6.528	-	6.324	-	-	-
7 . 1		7.029	-	7.06	-	6.986	-	7.36	-
8 . 0		7.752	7.7	7.729	8.393	8.016	7.93	8.153	8.221
9 . 0		8.578	8.873	8.82	9.078	8.935	8.76	9.221	9.106
1 0 .		9.531	9.785	9.929	9.938	9.765	10.051	10.104	10.293
1 1 .		10.643	10.828	11.063	11.34	10.957	11.204	11.324	11.285
1 2 .		11.957	12.031	12.641	12.766	12.797	12.245	12.765	12.647
1 4 .		13.534	13.435	14.36	14.223	14.092	13.739	14.494	14.257
1 6 .		15.462	15.094	15.504	16.253	15.982	16.047	16.608	16.188
1 8 .		-	17.084	-	18.463	-	17.671	17.851	18.549
2 0 .		-	19.517	-	19.934	-	20.04	-	19.938

##### Triple Reduction

Nominal Ratio Column Entry	UNIT - SIZE								
	6 7 8	G14	G15	G16	G17	G18	G19	G21	G22
1 8 .		17.401	-	17.934	-	17.539	-	-	-
2 0 .		19.335	-	20.19	-	19.168	-	20.569	-
2 2 .		21.591	21.966	22.494	23.058	21.507	21.994	23.051	22.973
2 5 .		24.256	24.406	25.704	25.958	25.12	24.036	25.985	25.746
2 8 .		27.455	27.254	29.199	28.921	27.662	26.969	29.506	29.023
3 2 .		31.365	30.619	31.525	33.048	31.371	31.499	33.809	32.955
3 6 .		34.721	34.657	35.77	37.542	35.182	34.688	36.34	37.761
4 0 .		38.579	39.592	40.269	40.532	38.45	39.339	41.011	40.587
4 5 .		43.08	43.828	44.865	45.99	43.141	44.117	45.96	45.804
5 0 .		48.399	48.698	51.268	51.774	50.388	48.215	51.81	51.332
5 6 .		54.782	54.379	58.239	57.683	55.488	54.098	58.829	57.865
6 3 .		62.583	61.094	62.877	65.916	62.928	63.185	67.408	65.705
7 1 .		-	69.151	-	74.879	-	69.58	72.455	75.287
8 0 .		-	78.999	-	80.842	-	78.909	-	80.924

##### Quadruple Reduction

Nominal Ratio Column Entry	UNIT - SIZE								
	6 7 8	G14	G15	G16	G17	G18	G19	G21	G22
7 1 .		70.494	-	71.59	-	73.105	-	-	-
8 0 .		78.327	-	81.324	-	80.504	-	79.169	-
9 0 .		87.465	88.984	87.8	92.044	91.298	91.671	90.715	88.423
1 0 0		98.265	98.872	104.001	104.559	102.455	100.949	97.506	101.318
1 1 2		111.224	110.407	118.142	112.886	112.825	114.485	115.479	108.903
1 2 5		127.063	124.039	127.55	133.716	127.953	128.475	132.32	128.977
1 4 0		136.419	140.398	140.233	151.897	140.825	141.479	142.226	147.786
1 6 0		153.263	160.392	166.109	163.993	158.034	160.449	159.476	158.85
1 8 0		173.476	172.201	188.694	180.299	174.029	176.59	188.872	178.116
2 0 0		198.181	193.464	203.721	213.568	197.364	198.17	216.416	210.948
2 2 5		-	218.978	-	242.607	-	218.227	232.618	241.712
2 5 0		-	250.163	-	261.927	-	247.488	-	259.808

# SERIES G

## PARALLEL SHAFT UNIT MECHANICAL RATINGS AT 1750 RPM INPUT

NOMINAL RATIO	NOMINAL OUTPUT SPEED rev / min	CAPACITY	PARALLEL SHAFT UNITS - SIZE								
			G14	G15	G16	G17	G18	G19	G21	G22	
6.3	278	Input Power - kW	288	-	551	-	1250	-	-	-	DOUBLE REDUCTION
		Output Torque - Nm	9330	-	19100	-	42300	-	-	-	
7.1	246	Input Power - kW	260	-	534	-	1170	-	2250	-	
		Output Torque - Nm	9680	-	20000	-	43900	-	89000	-	
8.0	219	Input Power - kW	242	291	497	551	1060	1250	2250	2250	
		Output Torque - Nm	9930	11900	20400	24600	45400	53000	98000	99300	
9.0	194	Input Power - kW	224	262	461	534	986	1170	2250	2250	
		Output Torque - Nm	10200	12300	21600	25800	47000	55000	110000	110000	
10.	175	Input Power - kW	206	244	424	497	950	1060	2150	2250	
		Output Torque - Nm	10400	12700	22300	26200	49500	57000	116000	124000	
11.	156	Input Power - kW	187	227	387	461	875	986	1980	2150	
		Output Torque - Nm	10500	13000	22700	27700	51000	59000	119000	130000	
12.	140	Input Power - kW	169	208	368	424	761	950	1815	1980	
		Output Torque - Nm	10700	13200	24500	28700	51700	62100	123000	134000	
14.	125	Input Power - kW	151	189	314	387	724	875	1630	1820	
		Output Torque - Nm	10800	13400	23800	29200	54100	64000	125000	139000	
16.	109.4	Input Power - kW	135	170	295	372	648	761	1470	1630	
		Output Torque - Nm	11000	13600	24200	31900	54800	64900	130000	141000	
18.	97.2	Input Power - kW	116	153	238	314	570	724	1360	1510	
		Output Torque - Nm	10600	13600	22400	30600	52700	67900	130000	149000	
20.	87.5	Input Power - kW	108	136	229	295	570	648	1185	1430	
		Output Torque - Nm	11000	14000	24200	31100	57500	68800	130000	152000	
22.	79.5	Input Power - kW	97.8	116	210	238	512	570	1060	1200	
		Output Torque - Nm	11000	13300	24700	28800	57900	66100	130000	147000	
25.	70.0	Input Power - kW	87.9	107	191	238	445	570	941	1180	
		Output Torque - Nm	11000	13700	25600	32400	58600	72200	130000	161000	
28.	62.5	Input Power - kW	78.4	96.6	168	230	405	512	830	1050	
		Output Torque - Nm	11000	13800	25600	34900	58600	76800	130000	161000	
32.	54.7	Input Power - kW	69.2	86.6	156	204	357	479	726	926	
		Output Torque - Nm	11000	13900	25600	35200	58600	79100	130000	161000	
36.	48.6	Input Power - kW	59.8	77.4	137	180	305	435	676	810	
		Output Torque - Nm	11000	14000	25600	35300	58600	79100	130000	161000	
40.	43.8	Input Power - kW	54.4	68.4	122	167	292	384	600	755	
		Output Torque - Nm	11000	14000	25600	35400	58600	79200	130000	161000	
45.	39.9	Input Power - kW	49.2	59.1	110	143	261	305	536	670	
		Output Torque - Nm	11000	13500	25600	34400	58600	70100	130000	161000	
50.	35.0	Input Power - kW	44.2	53.7	96	129	223	305	476	599	
		Output Torque - Nm	11000	13700	25600	34700	58600	76600	130000	161000	
56.	31.3	Input Power - kW	39.4	48.6	84.6	116	203	281	420	532	
		Output Torque - Nm	11000	13800	25600	34900	58600	79200	130000	161000	
63.	27.8	Input Power - kW	34.8	43.6	78.4	103	179	241	367	470	
		Output Torque - Nm	11000	14000	25600	35200	58600	79200	130000	161000	
71.	24.6	Input Power - kW	29.4	38.9	69.4	90.5	137	219	342	411	
		Output Torque - Nm	10700	14000	25600	35300	51500	79200	130000	161000	
80.	21.9	Input Power - kW	26.7	34.4	61.2	84.3	129	193	315	382	
		Output Torque - Nm	10800	14000	25600	35400	53300	79200	130000	161000	
90.	19.4	Input Power - kW	24.1	28.7	56.7	70.5	118	153	275	352	
		Output Torque - Nm	10900	13300	25600	33500	55600	72400	130000	162000	
100	17.5	Input Power - kW	21.7	25.8	47.9	62.7	108	144	256	308	
		Output Torque - Nm	11000	13200	25600	33800	57000	75200	130000	162000	
112	15.6	Input Power - kW	19.3	23.2	42.2	59	101	133	217	287	
		Output Torque - Nm	11000	13600	25600	34300	58600	78400	130000	162000	
125	14.0	Input Power - kW	17.1	20.6	39.2	49.7	89.3	120	190	243	
		Output Torque - Nm	11000	13800	25600	34200	58600	79300	130000	162000	
140	12.5	Input Power - kW	15.5	18.3	35.6	43.8	81	109	177	212	
		Output Torque - Nm	11000	14000	25600	34200	58600	79300	130000	162000	
160	10.9	Input Power - kW	13.9	16	30.1	40.7	72.3	96.3	158	198	
		Output Torque - Nm	11000	14000	25600	34300	58600	79300	130000	162000	
180	9.7	Input Power - kW	12.4	14.9	26.5	37	65.7	87.4	133	177	
		Output Torque - Nm	11000	14000	25600	34300	58600	79300	130000	162000	
200	8.8	Input Power - kW	10.9	13.2	24.6	31.2	58	78	116	149	
		Output Torque - Nm	11000	14000	25600	34200	58600	79300	130000	162000	
225	7.8	Input Power - kW	-	11.7	-	27.4	-	70.9	108	130	
		Output Torque - Nm	-	14000	-	34200	-	79300	130000	162000	
250	7.0	Input Power - kW	-	10.3	-	25.5	-	62.6	-	121.0	
		Output Torque - Nm	-	14000	-	34200	-	79300	-	162000	

**Bold Text: Forced lubrication System Required**



# SERIES G

## PARALLEL SHAFT UNIT MECHANICAL RATINGS AT 1450 RPM INPUT

NOMINAL RATIO	NOMINAL OUTPUT SPEED rev / min	CAPACITY	PARALLEL SHAFT UNITS - SIZE								
			G14	G15	G16	G17	G18	G19	G21	G22	
6.3	230	Input Power - kW	253	-	483	-	1090	-	-	-	DOUBLE REDUCTION
		Output Torque - Nm	9870	-	20200	-	44700	-	-	-	
7.1	204	Input Power - kW	228	-	468	-	1030	-	1860	-	
		Output Torque - Nm	10200	-	21200	-	46400	-	89000	-	
8.0	181	Input Power - kW	210	255	435	483	930	1090	1860	1860	
		Output Torque - Nm	10400	12600	21600	26000	48000	56100	98000	99300	
9.0	161	Input Power - kW	192	230	404	468	865	1030	1860	1860	
		Output Torque - Nm	10500	13100	22800	27200	49700	58200	110000	110000	
10.	145	Input Power - kW	175	213	372	435	833	930	1860	1860	
		Output Torque - Nm	10600	13300	23600	27700	52300	60200	122000	124000	
11.	129	Input Power - kW	159	194	339	404	767	865	1760	1860	
		Output Torque - Nm	10800	13500	24000	29300	53900	62300	129000	136000	
12.	116	Input Power - kW	143	177	313	372	667	833	1570	1740	
		Output Torque - Nm	10900	13600	25200	30400	54700	65600	130000	142000	
14.	104	Input Power - kW	129	160	275	339	635	767	1380	1590	
		Output Torque - Nm	11000	13800	25200	30800	57200	67600	130000	147000	
16.	90.6	Input Power - kW	115	144	259	320	568	667	1210	1430	
		Output Torque - Nm	11000	13900	25600	33200	58000	68600	130000	149000	
18.	80.6	Input Power - kW	96.6	129	209	275	500	635	1130	1300	
		Output Torque - Nm	10600	14000	23700	32400	55700	71800	130000	155000	
20.	72.5	Input Power - kW	89.6	114	201	259	482	568	984	1220	
		Output Torque - Nm	11000	14000	25600	32900	58600	72700	130000	156000	
22.	65.9	Input Power - kW	81	96.6	180	209	430	500	879	1040	
		Output Torque - Nm	11000	13400	25600	30400	58600	70000	130000	152000	
25.	58.0	Input Power - kW	72.8	88.5	158	209	369	500	780	980	
		Output Torque - Nm	11000	13700	25600	34300	58600	76300	130000	161000	
28.	51.8	Input Power - kW	64.9	80	139	191	335	449	689	871	
		Output Torque - Nm	11000	13800	25600	34900	58600	76800	130000	161000	
32.	45.3	Input Power - kW	57.3	71.9	129	169	296	397	602	769	
		Output Torque - Nm	11000	13900	25600	35200	58600	79100	130000	161000	
36.	40.3	Input Power - kW	49.5	64.1	114	149	265	361	561	672	
		Output Torque - Nm	11000	14000	25600	35300	58600	79100	130000	161000	
40.	36.3	Input Power - kW	45	56.6	101	139	242	319	498	627	
		Output Torque - Nm	11000	14000	25600	35400	58600	79200	130000	161000	
45.	32.2	Input Power - kW	40.7	48.9	90.8	119	216	267	445	557	
		Output Torque - Nm	11000	13500	25600	34400	58600	74200	130000	161000	
50.	29.0	Input Power - kW	36.6	44.5	79.6	107	185	261	395	497	
		Output Torque - Nm	11500	13700	25600	34700	58600	79200	130000	161000	
56.	25.9	Input Power - kW	32.6	40.2	70.1	96	168	233	349	442	
		Output Torque - Nm	11000	13800	25600	34900	58600	79200	130000	161000	
63.	23.0	Input Power - kW	28.8	36.1	65	84.9	148	200	304	390	
		Output Torque - Nm	11000	14000	25600	35200	58600	79200	130000	161000	
71.	20.4	Input Power - kW	24.3	32.2	57.5	75	120	181	283	341	
		Output Torque - Nm	10700	14000	25600	35300	54500	79200	130000	161000	
80.	18.1	Input Power - kW	22.1	28.5	50.7	69.8	113	160	261	317	
		Output Torque - Nm	10800	14000	25600	35400	56400	79200	130000	162000	
90.	16.1	Input Power - kW	20	23.8	47	59.6	103	134	228	292	
		Output Torque - Nm	10900	13300	25600	34200	58600	76600	130000	162000	
100	14.5	Input Power - kW	17.9	21.4	39.7	52.5	92.2	126	213	256	
		Output Torque - Nm	11000	13200	25600	34200	58600	79300	130000	162000	
112	12.9	Input Power - kW	16	19.2	35	48.8	83.8	111	180	238	
		Output Torque - Nm	11000	13600	25600	34200	58600	79300	130000	162000	
125	11.6	Input Power - kW	14.1	17.1	32.4	41.2	74	99.4	157	201	
		Output Torque - Nm	11000	13800	25600	34200	58600	79300	130000	162000	
140	10.4	Input Power - kW	12.8	15.1	29.4	36.3	67.1	90.4	146	176	
		Output Torque - Nm	11000	14000	25600	34200	58600	79300	130000	162000	
160	9.1	Input Power - kW	11.5	13.3	24.9	33.7	59.9	79.8	131	164	
		Output Torque - Nm	11000	14000	25600	34200	58600	79300	130000	162000	
180	8.1	Input Power - kW	10.3	12.3	21.9	30.6	54.4	72.4	110	146	
		Output Torque - Nm	11000	14000	25600	34200	58600	79300	130000	162000	
200	7.3	Input Power - kW	9.1	11	20.3	25.8	48	64.6	96.5	124	
		Output Torque - Nm	11000	14000	25600	34200	58600	79300	130000	162000	
225	6.4	Input Power - kW	-	9.7	-	22.7	-	58.7	89.2	108	
		Output Torque - Nm	-	14000	-	34200	-	79300	130000	162000	
250	5.8	Input Power - kW	-	8.5	-	21.1	-	51.8	-	101.0	
		Output Torque - Nm	-	14000	-	34200	-	79300	-	162000	

# SERIES G

## PARALLEL SHAFT UNIT MECHANICAL RATINGS AT 1160 RPM INPUT

NOMINAL RATIO	NOMINAL OUTPUT SPEED rev / min	CAPACITY	PARALLEL SHAFT UNITS - SIZE								
			G14	G15	G16	G17	G18	G19	G21	G22	
6.3	184	Input Power - kW	214	-	413	-	937	-	-	-	DOUBLE REDUCTION
		Output Torque - Nm	10400	-	21600	-	47700	-	-	-	
7.1	163	Input Power - kW	189	-	400	-	881	-	1490	-	
		Output Torque - Nm	10600	-	22600	-	49500	-	89000	-	
8.0	145	Input Power - kW	173	211	372	413	796	937	1490	1490	
		Output Torque - Nm	10700	13000	23000	27800	51200	59800	98000	99200	
9.0	129	Input Power - kW	158	187	345	400	740	881	1490	1490	
		Output Torque - Nm	10900	13300	24400	29100	53000	62100	110000	110000	
10.	116	Input Power - kW	144	171	318	372	713	796	1490	1490	
		Output Torque - Nm	11000	13400	25200	29600	55800	64300	122000	124000	
11.	104	Input Power - kW	130	156	289	345	656	740	1410	1490	
		Output Torque - Nm	11000	13500	25600	31300	57600	66500	129000	136000	
12.	93	Input Power - kW	117	142	254	318	570	713	1260	1490	
		Output Torque - Nm	11000	13700	25600	32400	58400	70000	130000	152000	
14.	83	Input Power - kW	104	129	223	290	520	656	1110	1350	
		Output Torque - Nm	11000	13800	25600	33000	58600	72300	130000	155000	
16.	72.5	Input Power - kW	92	115	207	264	460	570	970	1190	
		Output Torque - Nm	11000	13900	25600	34300	58600	73200	130000	155000	
18.	64.4	Input Power - kW	77.8	103	179	235	422	543	900	1070	
		Output Torque - Nm	10700	14000	25300	34600	58600	76700	130000	159000	
20.	58.0	Input Power - kW	71.7	90.9	161	222	386	486	788	1010	
		Output Torque - Nm	11000	14000	25600	35200	58600	77600	130000	161000	
22.	52.7	Input Power - kW	64.8	77.8	144	179	345	425	704	866	
		Output Torque - Nm	11000	13500	25600	32600	58600	74100	130000	159000	
25.	46.4	Input Power - kW	58.2	70.8	126	169	295	416	625	786	
		Output Torque - Nm	11000	13700	25600	34700	58600	79100	130000	161000	
28.	41.4	Input Power - kW	51.9	64	111	153	268	371	552	698	
		Output Torque - Nm	11000	13800	25600	34900	58600	79100	130000	161000	
32.	36.3	Input Power - kW	45.9	57.5	103	135	237	318	482	616	
		Output Torque - Nm	11000	13900	25600	35200	58600	79200	130000	161000	
36.	32.2	Input Power - kW	39.6	51.3	90.9	119	212	289	449	539	
		Output Torque - Nm	11000	14000	25600	35300	58600	79200	130000	161000	
40.	29.0	Input Power - kW	36	45.3	80.8	111	194	255	399	502	
		Output Torque - Nm	11000	14000	25600	35400	58600	79200	130000	161000	
45.	25.8	Input Power - kW	32.6	39.1	72.6	94.9	173	228	357	447	
		Output Torque - Nm	11000	13500	25600	34400	58600	79200	130000	161000	
50.	23.2	Input Power - kW	29.3	35.6	63.7	85.2	148	209	317	399	
		Output Torque - Nm	11000	13700	25600	34700	58600	79200	130000	161000	
56.	20.7	Input Power - kW	26.1	32.2	56.1	76.8	135	186	279	354	
		Output Torque - Nm	11000	13800	25600	34900	58600	79200	130000	162000	
63.	18.4	Input Power - kW	23	28.9	52	67.9	119	160	244	312	
		Output Torque - Nm	11000	14000	25600	35200	58600	79300	130000	162000	
71.	16.3	Input Power - kW	19.4	25.8	46	60	103	145	227	273	
		Output Torque - Nm	10700	14000	25600	35300	58300	79300	130000	162000	
80.	14.5	Input Power - kW	17.7	22.8	40.5	55.8	93.6	128	209	254	
		Output Torque - Nm	10800	14000	25600	35400	58600	79300	130000	162000	
90.	12.9	Input Power - kW	16	19	37.6	47.7	82.7	111	183	234	
		Output Torque - Nm	10900	13300	25600	34200	58600	79300	130000	162000	
100	11.6	Input Power - kW	14.3	17.1	31.7	42.1	73.7	101	170	205	
		Output Torque - Nm	11000	13400	25600	34300	58600	79300	130000	162000	
112	10.4	Input Power - kW	12.8	15.3	28	39.1	67	89.2	144	191	
		Output Torque - Nm	11000	13600	25600	34300	58600	79300	130000	162000	
125	9.3	Input Power - kW	11.3	13.7	25.9	32.9	59.2	79.5	126	161	
		Output Torque - Nm	11000	13600	25600	34200	58600	79300	130000	162000	
140	8.3	Input Power - kW	10.3	12.1	23.6	29	53.7	72.3	117	141	
		Output Torque - Nm	11000	14000	25600	34200	58600	79300	130000	162000	
160	7.3	Input Power - kW	9.2	10.6	19.9	27	47.9	63.8	104	131	
		Output Torque - Nm	11000	14000	25600	34300	58600	79300	130000	162000	
180	6.4	Input Power - kW	8.2	9.8	17.5	24.5	43.5	57.9	88.4	117	
		Output Torque - Nm	11000	14000	25600	34300	58600	79300	130000	162000	
200	5.8	Input Power - kW	7.3	8.8	16.3	20.6	38.4	51.7	77.2	99	
		Output Torque - Nm	11000	14000	25600	34200	58600	79300	130000	162000	
225	5.2	Input Power - kW	-	7.8	-	18.2	-	46.9	71.9	87	
		Output Torque - Nm	-	14000	-	34200	-	79300	130000	162000	
250	4.6	Input Power - kW	-	6.8	-	16.9	-	41.4	-	80.5	
		Output Torque - Nm	-	14000	-	34200	-	79300	-	162000	

# SERIES G

## PARALLEL SHAFT UNIT MECHANICAL RATINGS AT 960 RPM INPUT

NOMINAL RATIO	NOMINAL OUTPUT SPEED rev / min	CAPACITY	PARALLEL SHAFT UNITS - SIZE								
			G14	G15	G16	G17	G18	G19	G21	G22	
6.3	152	Input Power - kW	177	-	352	-	820	-	-	-	DOUBLE REDUCTION
		Output Torque - Nm	10400	-	22300	-	50400	-	-	-	
7.1	135	Input Power - kW	156	-	350	-	771	-	1230	-	
		Output Torque - Nm	10600	-	23900	-	52300	-	89000	-	
8.0	120	Input Power - kW	143	175	326	352	697	820	1230	1230	
		Output Torque - Nm	10800	13000	24400	28600	54200	63200	98000	99100	
9.0	107	Input Power - kW	131	155	300	350	648	771	1230	1230	
		Output Torque - Nm	10900	13300	25500	30800	56100	65600	110000	110000	
10.	96	Input Power - kW	119	142	267	326	619	697	1230	1230	
		Output Torque - Nm	11000	13400	25600	31300	58600	68000	122000	124000	
11.	86	Input Power - kW	108	129	240	303	553	648	1170	1230	
		Output Torque - Nm	11000	13500	25600	33200	58600	70400	12900	136000	
12.	77	Input Power - kW	96.7	118	210	279	474	624	1040	1230	
		Output Torque - Nm	11000	13700	25600	34300	58600	74100	130000	152000	
14.	69	Input Power - kW	86.2	106	185	254	431	575	920	1150	
		Output Torque - Nm	11000	13800	25600	34900	58600	76400	130000	159000	
16.	60.0	Input Power - kW	76.1	95.5	172	225	381	500	800	1010	
		Output Torque - Nm	11000	13900	25600	35200	58600	77500	130000	159000	
18.	53.3	Input Power - kW	64.7	85.2	149	198	350	464	750	897	
		Output Torque - Nm	10800	14000	25600	35300	58600	79100	130000	161000	
20.	48.0	Input Power - kW	59.3	75.2	133	185	320	410	653	835	
		Output Torque - Nm	11000	14000	25600	35400	58600	79100	130000	161000	
22.	43.6	Input Power - kW	53.6	64.4	119	156	285	352	583	729	
		Output Torque - Nm	11000	13500	25600	34400	58600	74000	130000	161000	
25.	38.4	Input Power - kW	48.2	58.6	105	140	245	345	518	652	
		Output Torque - Nm	11000	13700	25600	34700	58600	79200	130000	161000	
28.	34.3	Input Power - kW	43	53	92.2	126	222	307	457	579	
		Output Torque - Nm	11000	13800	25600	34900	58600	79200	130000	161000	
32.	30.0	Input Power - kW	37.9	47.6	85.5	112	196	264	400	511	
		Output Torque - Nm	11000	13900	25600	35200	58600	79100	130000	161000	
36.	26.7	Input Power - kW	32.8	42.4	75.3	98.7	175	240	372	447	
		Output Torque - Nm	10900	14000	25600	35300	58600	79100	130000	161000	
40.	24.0	Input Power - kW	29.8	37.5	66.9	91.8	160	212	331	416	
		Output Torque - Nm	11000	14000	25600	35400	58600	79200	130000	161000	
45.	21.3	Input Power - kW	27	32.4	60.1	78.5	143	189	295	370	
		Output Torque - Nm	11000	13500	25600	34400	58600	74200	130000	161000	
50.	19.2	Input Power - kW	24.2	29.4	52.7	70.5	123	173	262	330	
		Output Torque - Nm	11000	13700	25600	34700	58600	79200	130000	162000	
56.	17.1	Input Power - kW	21.6	26.6	46.4	63.6	111	154	231	293	
		Output Torque - Nm	11000	13800	25600	34900	58600	79200	130000	162000	
63.	15.2	Input Power - kW	19.1	23.9	43	56.2	98.3	132	202	259	
		Output Torque - Nm	11000	14000	25600	35200	58600	79200	130000	162000	
71.	13.5	Input Power - kW	16.1	21.3	38	49.6	85.3	120	188	226	
		Output Torque - Nm	10700	14000	25600	35300	58600	79200	130000	162000	
80.	12.0	Input Power - kW	14.6	18.8	33.5	46.2	77.5	106	173	210	
		Output Torque - Nm	10800	14000	25600	35400	58600	79200	130000	162000	
90.	10.7	Input Power - kW	13.2	15.7	31.1	39.5	68.4	91.9	151	194	
		Output Torque - Nm	10900	13300	25600	34200	58600	79300	130000	162000	
100	9.6	Input Power - kW	11.9	14.2	26.3	34.7	61	83.5	141	170	
		Output Torque - Nm	11000	13400	25600	34200	58600	79300	130000	162000	
112	8.6	Input Power - kW	10.6	12.7	23.1	32.3	55.4	73.8	119	158	
		Output Torque - Nm	11000	13600	25600	34300	58600	79300	130000	162000	
125	7.7	Input Power - kW	9.3	11.3	21.5	27.2	48.9	65.8	104	134	
		Output Torque - Nm	11000	13800	25600	34200	58600	79300	130000	162000	
140	6.9	Input Power - kW	8.5	10	19.5	24	44.4	59.8	96.9	117	
		Output Torque - Nm	11000	14000	25600	34200	58600	79300	130000	162000	
160	6.0	Input Power - kW	7.6	8.8	16.5	22.3	39.6	52.8	86.4	109	
		Output Torque - Nm	11000	14000	25600	34300	58600	79300	130000	162000	
180	5.3	Input Power - kW	6.8	8.1	14.5	20.3	36	47.9	73.1	97	
		Output Torque - Nm	11000	14000	25600	34300	58600	79300	130000	162000	
200	4.8	Input Power - kW	6	7.3	13.5	17.1	31.8	42.7	63.8	82	
		Output Torque - Nm	11000	14000	25600	34200	58600	79300	130000	162000	
225	4.3	Input Power - kW	-	6.4	-	15	-	38.8	59.4	72	
		Output Torque - Nm	-	14000	-	34200	-	79300	130000	162000	
250	3.8	Input Power - kW	-	5.6	-	14	-	34.3	-	66.6	
		Output Torque - Nm	-	14000	-	34300	-	79300	-	162000	

# SERIES G

## PARALLEL SHAFT UNIT MECHANICAL RATINGS AT 725 RPM INPUT

NOMINAL RATIO	NOM	M,P	PARALLEL SHAFT UNITS - SIZE								
			G14	G15	G16	G17	G18	G19	G21	G22	
6.3	115	Input Power - kW	134	-	266	-	634	-	-	-	DOUBLE REDUCTION
		Output Torque - Nm	10400	-	22300	-	51500	-	-	-	
7.1	102	Input Power - kW	118	-	266	-	634	-	935	-	
		Output Torque - Nm	10600	-	24000	-	56900	-	89000	-	
8.0	91	Input Power - kW	108	132	258	266	570	634	935	935	
		Output Torque - Nm	10800	13000	25600	28600	58600	64600	98000	99200	
9.0	81	Input Power - kW	98.9	117	227	266	512	634	935	935	
		Output Torque - Nm	10900	13300	25600	30900	58600	71300	110000	109000	
10.	73	Input Power - kW	89.9	107	202	266	468	573	935	935	
		Output Torque - Nm	11000	13400	25600	33800	58600	73900	122000	124000	
11.	65	Input Power - kW	81.3	97.7	181	237	418	532	885	932	
		Output Torque - Nm	11000	13500	25600	34400	58600	76500	129000	135000	
12.	58	Input Power - kW	73.1	88.8	159	213	358	504	785	932	
		Output Torque - Nm	11000	13700	25600	34700	58600	79100	130000	152000	
14.	52	Input Power - kW	65.1	70.3	140	192	326	450	695	879	
		Output Torque - Nm	11000	13800	25600	34900	58600	79100	130000	161000	
16.	45.3	Input Power - kW	57.5	72.1	130	170	287	386	603	776	
		Output Torque - Nm	11000	14000	25600	35200	58600	79100	130000	161000	
18.	40.3	Input Power - kW	49.2	64.3	113	150	264	351	562	679	
		Output Torque - Nm	10800	14000	25600	35300	58600	79200	130000	161000	
20.	36.3	Input Power - kW	44.8	56.8	100	139	242	310	494	632	
		Output Torque - Nm	11000	14000	25600	35400	58600	79200	130000	161000	
22.	33.0	Input Power - kW	40.5	48.7	90.2	118	216	266	441	552	
		Output Torque - Nm	11000	13500	25600	34400	58600	74000	130000	161000	
25.	29.0	Input Power - kW	36.4	44.2	79	106	185	261	392	494	
		Output Torque - Nm	11000	13700	25600	34700	58600	79200	130000	161000	
28.	25.9	Input Power - kW	32.4	40	69.6	95.4	168	232	346	439	
		Output Torque - Nm	11000	13800	25600	34900	58600	79200	130000	161000	
32.	22.7	Input Power - kW	28.6	35.9	64.5	84.3	148	264	302	387	
		Output Torque - Nm	11000	13900	25600	35200	58600	79100	130000	161000	
36.	20.1	Input Power - kW	24.8	32	56.9	74.5	132	181	281	338	
		Output Torque - Nm	11000	14000	25600	35300	58600	79100	130000	162000	
40.	18.1	Input Power - kW	22.5	28.3	50.5	69.3	121	160	250	315	
		Output Torque - Nm	11000	14000	25600	35400	58600	79200	130000	162000	
45.	16.1	Input Power - kW	20.4	24.5	45.4	59.3	108	143	223	280	
		Output Torque - Nm	11000	13500	25600	34400	58600	74200	130000	162000	
50.	14.5	Input Power - kW	18.3	22.2	39.8	53.3	92.5	131	198	250	
		Output Torque - Nm	11000	13700	25600	34700	58600	79200	130000	162000	
56.	12.9	Input Power - kW	16.3	20.1	35	48	84	116	174	222	
		Output Torque - Nm	11000	13800	25600	34900	58600	79200	130000	162000	
63.	11.5	Input Power - kW	14.4	18.1	32.5	42.4	74.2	99.8	152	195	
		Output Torque - Nm	11000	14000	25600	35200	58600	79200	130000	162000	
71.	10.2	Input Power - kW	12.1	16.1	28.7	37.5	64.4	90.7	142	171	
		Output Torque - Nm	10700	14000	25600	35300	58600	79200	130000	162000	
80.	9.1	Input Power - kW	11	14.2	25.3	34.9	58.5	80	131	161	
		Output Torque - Nm	10800	14000	25600	35400	58600	79200	130000	165000	
90.	8.1	Input Power - kW	10	11.9	23.5	29.8	51.6	69.4	114	147	
		Output Torque - Nm	10900	13200	25600	34200	58600	79300	130000	162000	
100	7.3	Input Power - kW	9	10.7	19.8	26.2	46	63.1	106	128	
		Output Torque - Nm	11000	13400	25600	34200	58600	79300	130000	162000	
112	6.5	Input Power - kW	8	9.6	17.5	24.4	41.8	55.7	90	119	
		Output Torque - Nm	11000	13600	25600	34300	58600	79300	130000	162000	
125	5.8	Input Power - kW	7	8.5	16.2	20.6	36.9	49.7	78.6	101	
		Output Torque - Nm	11000	13800	25600	34200	58600	79300	130000	162000	
140	5.2	Input Power - kW	6.4	7.5	14.7	18.1	33.5	45.1	73.2	88	
		Output Torque - Nm	11000	14000	25600	34200	58600	79300	130000	162000	
160	4.5	Input Power - kW	5.8	6.6	12.4	16.8	29.9	39.9	65.3	82	
		Output Torque - Nm	11000	14000	25600	34300	58600	79300	130000	162000	
180	4.0	Input Power - kW	5.1	6.2	11	15.3	27.2	36.2	55.2	73	
		Output Torque - Nm	11000	14000	25600	34300	58600	79300	130000	162000	
200	3.6	Input Power - kW	4.5	5.5	10.2	12.9	24	32.3	48.2	62	
		Output Torque - Nm	11000	14000	25600	34200	58600	79300	130000	162000	
225	3.2	Input Power - kW	-	4.8	-	11.4	-	29.3	55.9	55	
		Output Torque - Nm	-	14000	-	34200	-	79300	130000	164000	
250	2.9	Input Power - kW	-	4.3	-	10.6	-	25.9	-	51.1	
		Output Torque - Nm	-	14000	-	34300	-	79300	-	164000	

# SERIES G

## PARALLEL SHAFT UNIT

### THERMAL RATINGS

#### Thermal Ratings kW

These thermal ratings assume the gear unit is in constant use working in an ambient temperature of 25°C \* installed in a large indoor space at sea level.

These ratings must be adjusted for alternative operating and environment conditions refer to Thermal ratings and service factors on page 6.

\*maximum bulk oil temperature 95°C

#### Parallel Shaft Units - Double Reduction

Type of Cooling	Input Speed (rev/min)	Ratio	G1420	G1520	G1620	G1720	G1820	G1920	G2120	G2220
No Additional Cooling	1750	8:1	82	92	138	131	217	165	196	208
		16:1	63	73	114	111	180	163	176	188
	1450	8:1	82	91	142	136	228	184	234	248
		16:1	63	73	119	116	191	182	212	227
	1160	8:1	81	89	146	140	239	200	267	281
		16:1	63	72	122	121	201	199	244	260
	960	8:1	81	89	149	143	245	211	287	303
		16:1	64	72	125	124	208	209	264	281
Fan Cooling	1750	8:1	148	151	239	231	374	348	415	438
		16:1	121	127	209	205	323	346	386	412
	1450	8:1	131	134	218	209	338	316	388	411
		16:1	106	112	189	185	291	314	361	385
	1160	8:1	114	117	197	187	303	286	362	383
		16:1	92	98	170	165	260	283	336	359
	960	8:1	103	106	182	172	279	264	344	364
		16:1	82	88	156	151	239	262	319	340
Cooling Coil	1750	8:1	224	238	372	378	653	558	584	612
		16:1	191	209	336	348	588	555	553	583
	1450	8:1	219	233	371	376	651	560	600	628
		16:1	188	206	336	346	588	557	568	600
	1160	8:1	215	229	371	375	649	561	614	644
		16:1	185	202	336	345	587	558	582	615
	960	8:1	213	226	371	373	648	562	623	654
		16:1	183	200	336	344	586	559	592	625
Fan and Cooling Coil	1750	8:1	265	273	431	434	746	663	713	748
		16:1	231	243	394	402	677	660	680	717
	1450	8:1	250	259	415	417	716	637	692	726
		16:1	217	231	379	386	650	633	660	696
	1160	8:1	235	246	400	401	688	611	672	706
		16:1	204	218	365	371	624	608	640	676
	960	8:1	225	236	390	390	669	594	658	691
		16:1	195	210	355	360	606	591	627	662

#### Parallel Shaft Units - Triple Reduction

Type of Cooling	Input Speed (rev/min)	Ratio	G1430	G1530	G1630	G1730	G1830	G1930	G2130	G2230
No Additional Cooling	1750	22:1	58	62	92	89	147	126	136	145
		56:1	39	45	68	69	109	97	115	124
	1450	22:1	56	60	92	91	151	139	160	170
		56:1	39	44	69	72	114	110	138	149
	1160	22:1	55	58	92	93	155	150	181	191
		56:1	39	44	70	74	119	120	158	169
	960	22:1	54	57	93	94	158	156	193	204
		56:1	38	43	71	75	122	127	170	182
Fan Cooling	1750	22:1	-	-	177	180	307	331	383	401
		56:1	-	-	143	152	249	282	351	370
	1450	22:1	-	-	158	161	272	296	351	368
		56:1	-	-	126	135	220	251	321	339
	1160	22:1	-	-	139	142	239	262	319	334
		56:1	-	-	110	118	192	221	290	307
	960	22:1	-	-	125	129	216	238	296	311
		56:1	-	-	99	107	173	200	268	284
Cooling Coil	1750	22:1	156	163	251	257	431	428	398	419
		56:1	124	136	211	225	365	374	366	388
	1450	22:1	151	158	247	253	425	426	406	427
		56:1	120	132	209	223	361	374	374	397
	1160	22:1	147	154	243	250	420	425	414	435
		56:1	117	129	206	220	358	373	382	405
	960	22:1	144	151	241	248	416	423	419	441
		56:1	115	126	204	219	355	373	387	411

#### Parallel Shafts - Quadruple Reduction

Type of Cooling	Input Speed (rev/min)	Ratio	G1440	G1540	G1640	G1740	G1840	G1940	G2140	G2240
No Additional Cooling	1750	100:1	36	41	63	65	103	102	116	129
		200:1	26	30	45	51	81	82	92	104
	1450	100:1	35	40	63	65	106	109	134	148
		200:1	26	30	46	52	84	89	109	122
	1160	100:1	35	39	63	66	109	115	149	163
		200:1	26	29	47	53	88	95	124	137
	960	100:1	34	38	63	66	111	118	159	172
		200:1	26	29	47	54	90	99	133	146

# SERIES G

## DIMENSIONS HORIZONTAL PARALLEL SHAFTS DOUBLE REDUCTION

**G 20 H** Double Reduction Parallel Shaft Units Horizontal

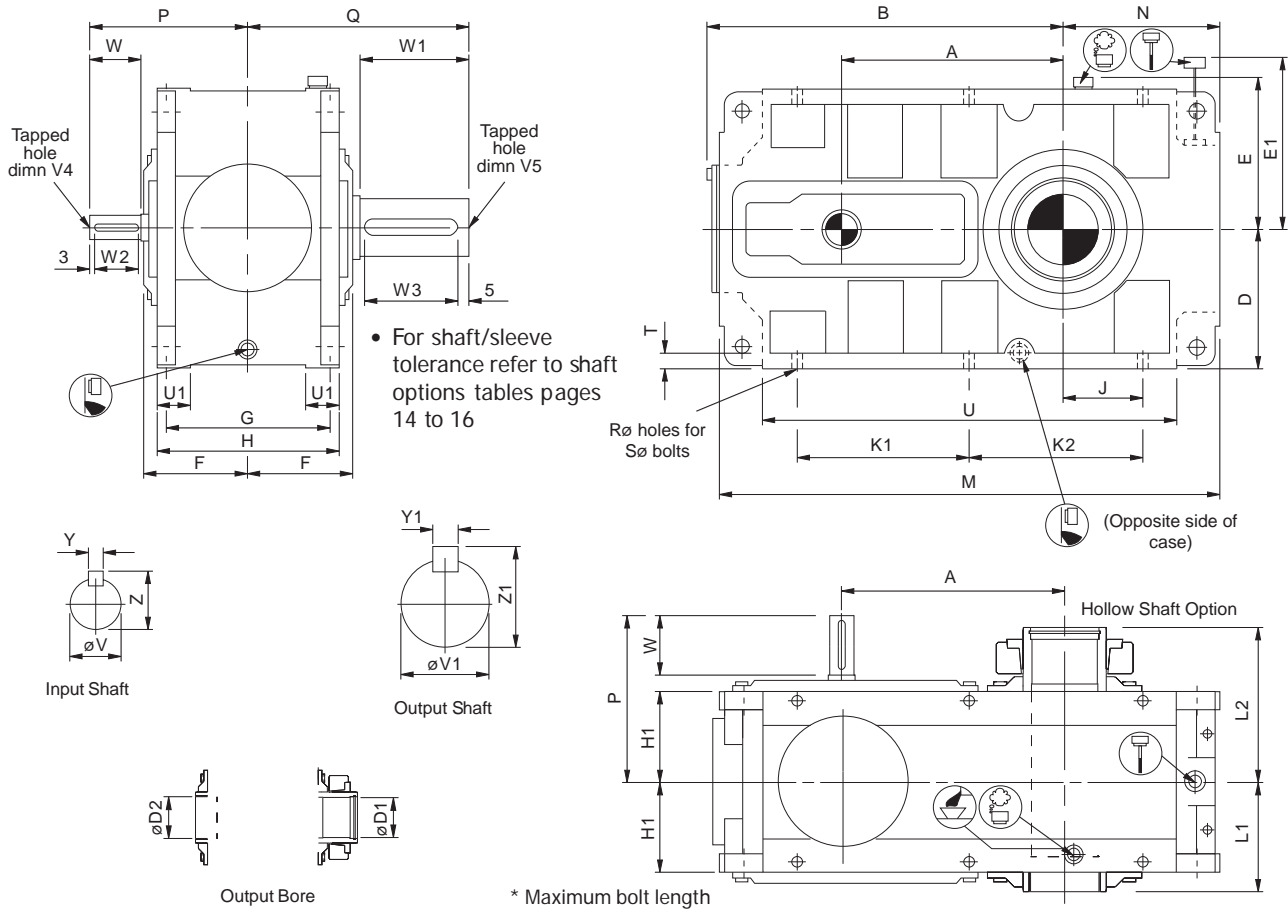

Unit Size	A	B	D	E	E1	F	G	H	H1	J	K1	K2	M	N	P	Q	R	S	T	U	U1
G14	325	554	230	250	370	177	265	300	150	170	285	820	295	315	360	18.5	6 x M16 x 60*	25	684	55	
G15	365	594	230	250	370	177	265	300	150	130	285	820	255	315	370	18.5	6 x M16 x 60*	25	684	55	
G16	430	728	300	335	515	225	330	380	190	225	385	1060	370	370	460	28	6 x M24 x 80*	30	898	70	
G17	485	783	300	335	515	225	330	380	190	170	385	1060	315	370	480	28	6 x M24 x 80*	30	898	70	
G18	570	953	385	420	710	290	440	500	250	153	520	350	1240	338	480	600	33	6 x M30 x 100*	37	1036	90
G19	635	1018	385	420	710	290	440	500	250	220	500	1374	407	480	650	33	6 x M30 x 100*	40	1170	90	
G21	765	1240	465	507	750	340	530	600	300	225	695	480	1655	465	560	700	39	6 x M36 x 100*	50	1380	120
G22	805	1280	465	507	750	340	530	600	300	245	755	490	1715	485	560	730	39	6 x M36 x 100*	50	1440	120

Unit Size	Input Shaft ●						Output Shaft ●						Output Bore ●			
	V	V4	W	W2	Y	Z	V1	V5	W1	W3	Y1	Z1	D1	D2	L1	L2
G14	50 k6	M16 x 36	138	130	14	53.5	110 m6	M30 x63	180	170	28	116	95	100	180	255
G15	50 k6	M16 x 36	138	130	14	53.5	130 m6	M30 x63	190	180	32	137	110	115	180	260
G16	60 m6	M20 x 43	148	140	18	64	145 m6	M42 x81	230	220	36	153	125	130	230	325
G17	60 m6	M20 x 43	148	140	18	64	170 m6	M42 x81	250	240	40	179	145	150	230	340
G18	85 m6	M24 x 52	190	180	22	90	190 m6	M42 x81	300	290	45	200	160	170	300	410
G19	85 m6	M24 x 52	190	180	22	90	210 m6	M42 x81	350	340	50	221	170	180	300	430
G21	110 m6	M30 x 63	210	200	28	116	220 m6	M42 x81	350	340	50	231	210	220	350	500
G22	110 m6	M30 x 63	210	200	28	116	240 m6	M42 x81	380	340	56	252	230	240	350	515

# SERIES G

## DIMENSIONS VERTICAL PARALLEL SHAFTS DOUBLE REDUCTION

### G 20 V Double Reduction Parallel Shaft Units Vertical

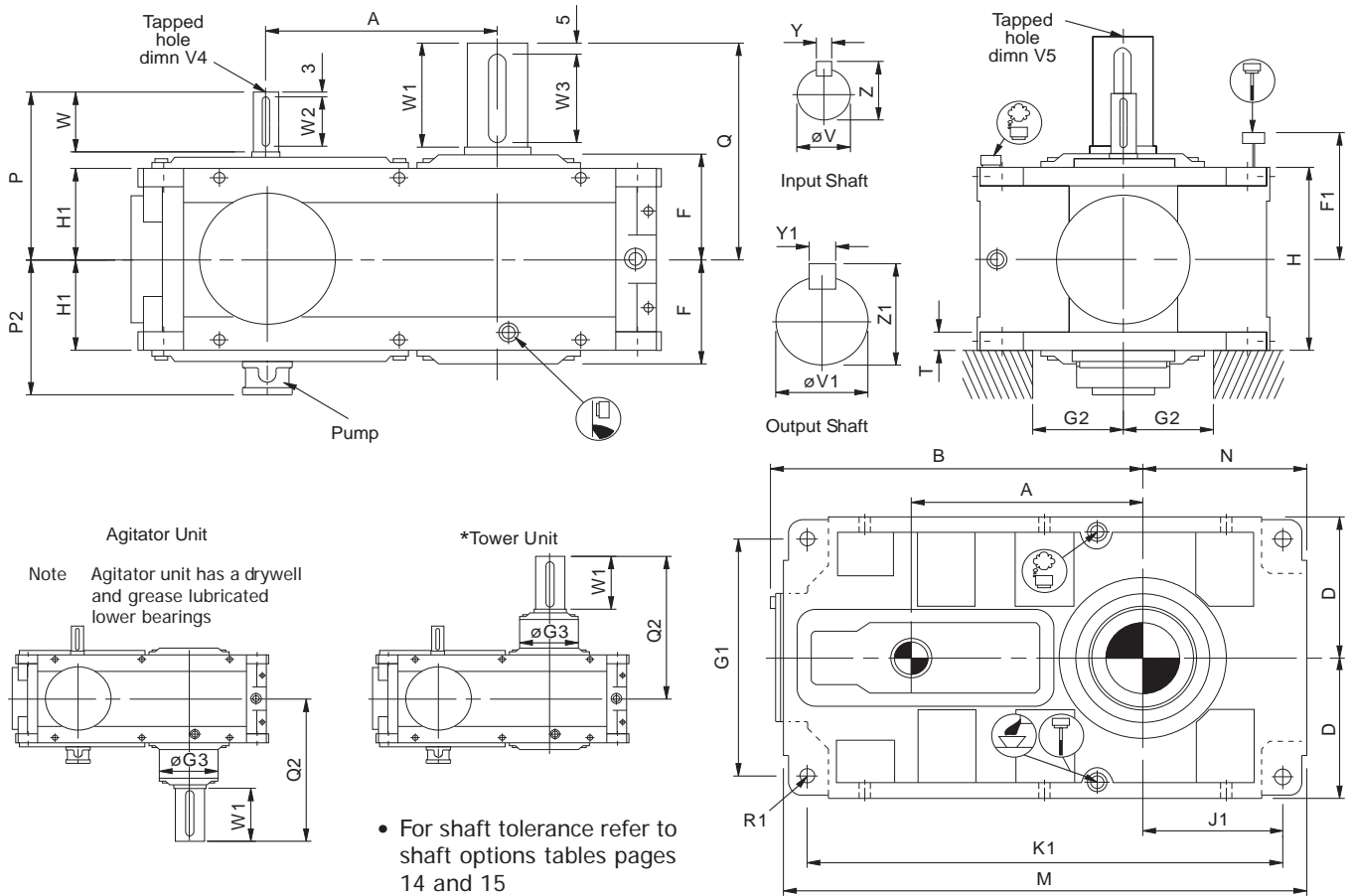

Unit Size	A	B	D	F	F1	G1	G2 (min)	G3	H	H1	J1	K1	M	N	P	P2	Q	Q2	R1	T
G14	325	554	230	177	390	390	135	230	300	150	260	750	820	295	315	236	360	475	4 X Ø 24	30
G15	365	594	230	177	390	390	135	260	300	150	220	750	820	255	315	236	370	495	4 X Ø 24	30
G16	430	728	300	225	515	506	175	300	380	190	325	970	1060	370	370	285	460	595	4 X Ø 33	45
G17	485	783	300	225	515	506	175	340	380	190	270	970	1060	315	370	285	480	615	4 X Ø 33	45
G18	570	953	385	290	700	656	205	370	500	250	281	1126	1240	338	480	345	600	760	4 X Ø 40	55
G19	635	1018	385	290	700	656	205	400	500	250	350	1260	1374	407	480	345	650	815	4 X Ø 40	55
G21	765	1240	465	340	750	790	255	500	600	300	395	1515	1655	465	560	400	700	925	4 X Ø 48	70
G22	805	1280	465	340	750	790	265	*	600	300	415	1575	1715	485	560	400	730	*	4 X Ø 48	70

Unit Size	Input Shaft •						Output Shaft •					
	V	V4	W	W2	Y	Z	V1	V5	W1	W3	Y1	Z1
G14	50 k6	M16 x 36	138	130	14	53.5	110 m6	M30 x63	180	170	28	116
G15	50 k6	M16 x 36	138	130	14	53.5	130 m6	M30 x63	190	180	32	137
G16	60 m6	M20 x 43	148	140	18	64	145 m6	M42 x81	230	220	36	153
G17	60 m6	M20 x 43	148	140	18	64	170 m6	M42 x81	250	240	40	179
G18	85 m6	M24 x 52	190	180	22	90	190 m6	M42 x81	300	290	45	200
G19	85 m6	M24 x 52	190	180	22	90	210 m6	M42 x81	350	340	50	221
G21	110 m6	M30 x 63	210	200	28	116	220 m6	M42 x81	350	340	50	231
G22	110 m6	M30 x 63	210	200	28	116	240 m6	M42 x81	380	340	56	252

\* = Contact Application Engineering

# SERIES G

## DIMENSIONS HORIZONTAL PARALLEL SHAFTS TRIPLE & QUADRUPLE REDUCTION

**G** 3 0 H Triple and Quadruple Reduction Parallel Shaft Units Horizontal

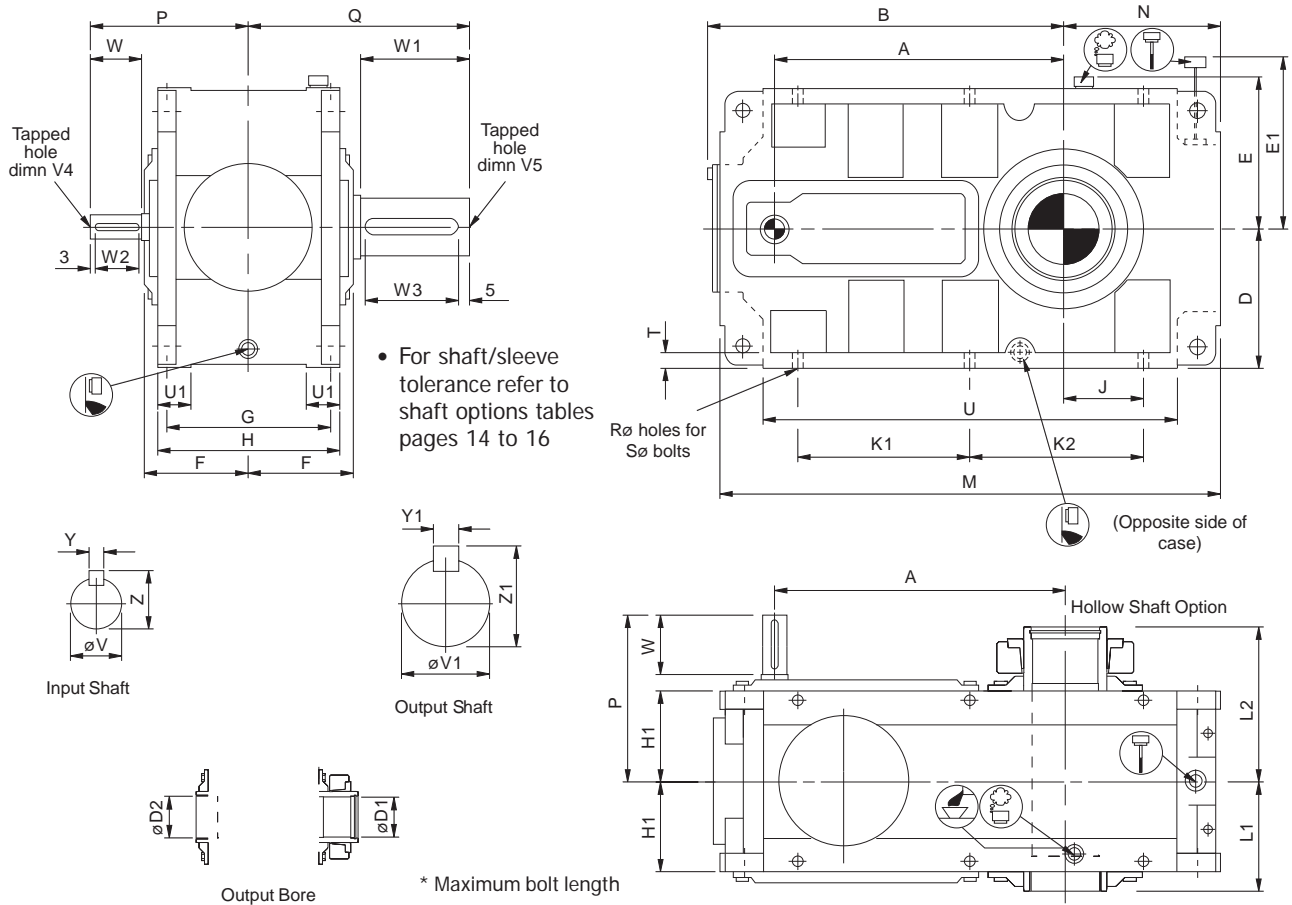

Unit Size	A	B	D	E	E1	F	G	H	H1	J	K1	K2	M	N	P	Q	R	S	T	U	U1
G14	435	554	230	250	370	177	265	300	150	170	285	820	295	275	360	18.5	6 X m16 X 60*	25	684	55	
G15	475	594	230	250	370	177	265	300	150	130	285	820	255	275	370	18.5	6 X m16 X 60*	25	684	55	
G16	570	728	300	335	515	225	330	380	190	225	385	1060	370	340	460	28	6 X m24 X 80*	30	898	70	
G17	625	783	300	335	515	225	330	380	190	170	385	1060	315	340	480	28	6 X m24 X 80*	30	898	70	
G18	755	953	385	420	710	290	440	500	250	153	520	350	1240	338	440	600	33	6 X m30 X 100*	37	1036	90
G19	820	1018	385	420	710	290	440	500	250	220	500	1374	407	440	650	33	6 X m30 X 100*	40	1170	90	
G21	1010	1240	465	507	750	340	530	600	300	225	695	480	1655	465	540	700	39	6 X m36 X 100*	50	1380	120
G22	1050	1280	465	507	750	340	530	600	300	245	745	490	1715	485	540	730	39	6 X m36 X 100*	50	1440	120

Unit Size	Input Shaft ●						Output Shaft ●						Output Bore ●			
	V	V4	W	W2	Y	Z	V1	V5	W1	W3	Y1	Z1	D1	D2	L1	L2
G14	35 k6	M12 x 25	99	90	10	38	110 m6	M30 x63	180	170	28	116	95	100	180	255
G15	35 k6	M12 x 25	99	90	10	38	130 m6	M30 x63	190	180	32	137	110	115	180	260
G16	45 m6	M16 x 36	118	110	14	48.5	145 m6	M42 x81	230	220	36	153	125	130	230	325
G17	45 m6	M16 x 36	118	110	14	48.5	170 m6	M42 x81	250	240	40	179	145	150	230	340
G18	60 m6	M20 x 43	150	140	18	64	190 m6	M42 x81	300	290	45	200	160	170	300	410
G19	60 m6	M20 x 43	150	140	18	64	210 m6	M42 x81	350	340	50	221	170	180	300	430
G21	80 m6	M20 x 43	190	180	22	85	220 m6	M42 x81	350	340	50	231	210	220	350	500
G22	80 m6	M20 x 43	190	180	22	85	240 m6	M42 x81	380	340	56	252	230	240	350	515



# SERIES G

## DIMENSIONS VERTICAL PARALLEL SHAFTS

### TRIPLE & QUADRUPLE REDUCTION

**G** 3 4 0 V Triple and Quadruple Reduction Parallel Shaft Units Vertical

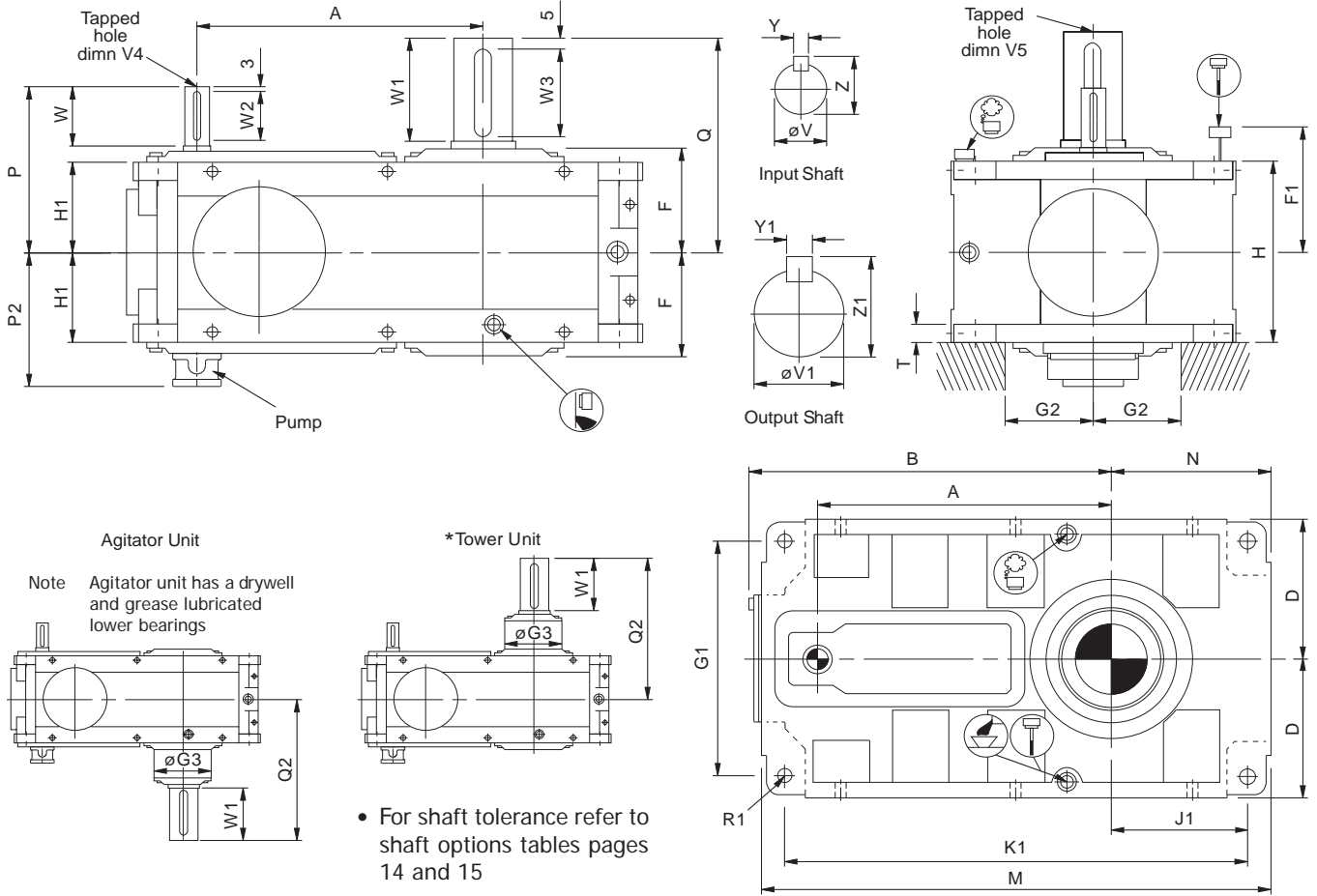

Unit Size	A	B	D	F	F1	G1	G2 min	G3	H	H1	J1	K1	M	N	P	P2	Q	Q2	R1	T
G14	435	554	230	177	390	390	135	230	300	150	260	750	820	295	275	236	360	475	4 X Ø 24	30
G15	475	594	230	177	390	390	135	260	300	150	220	750	820	255	275	236	370	495	4 X Ø 24	30
G16	570	728	300	225	515	506	175	300	380	190	325	970	1060	370	340	285	460	595	4 X Ø 33	45
G17	625	783	300	225	515	506	175	340	380	190	270	970	1060	315	340	285	480	615	4 X Ø 33	45
G18	755	953	385	290	700	656	205	370	500	250	281	1126	1240	338	440	345	600	760	4 X Ø 40	55
G19	820	1018	385	290	700	656	205	400	500	250	350	1260	1374	407	440	345	650	815	4 X Ø 40	55
G21	1010	1240	465	340	750	790	255	500	600	300	395	1515	1655	465	540	400	700	925	4 X 48	70
G22	1050	1280	465	340	750	790	265	*	600	300	415	1575	1715	485	540	400	730	*	4 X 48	70

Unit Size	Input Shaft •						Output Shaft •					
	V	V4	W	W2	Y	Z	V1	V5	W1	W3	Y1	Z1
G14	35 k6	M12 x 25	99	90	10	38	110 m6	M30 x63	180	170	28	116
G15	35 k6	M12 x 25	99	90	10	38	130 m6	M30 x63	190	180	32	137
G16	45 m6	M16 x 36	118	110	14	48.5	145 m6	M42 x81	230	220	36	153
G17	45 m6	M16 x 36	118	110	14	48.5	170 m6	M42 x81	250	240	40	179
G18	60 m6	M20 x 43	150	140	18	64	190 m6	M42 x81	300	290	45	200
G19	60 m6	M20 x 43	150	140	18	64	210 m6	M42 x81	350	340	50	221
G21	80 m6	M20 x 43	190	180	22	85	220 m6	M42 x81	350	340	50	231
G22	80 m6	M20 x 43	190	180	22	85	240 m6	M42 x81	380	340	56	252

\* = Contact Application Engineering

# SERIES G

## FAN COOLING DIMENSIONS PARALLEL SHAFTS

### Parallel Shaft Units with Mechanical Fans

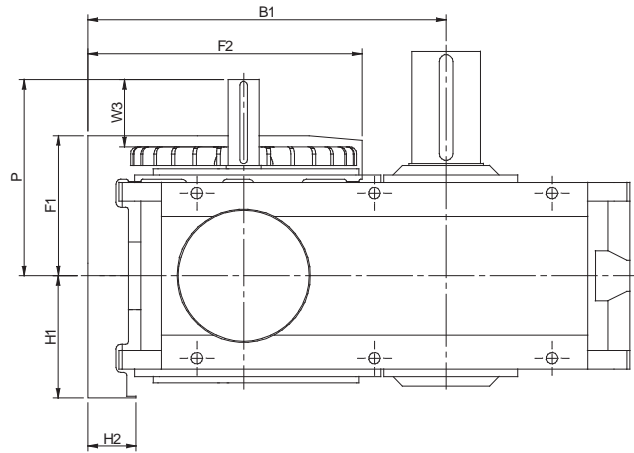
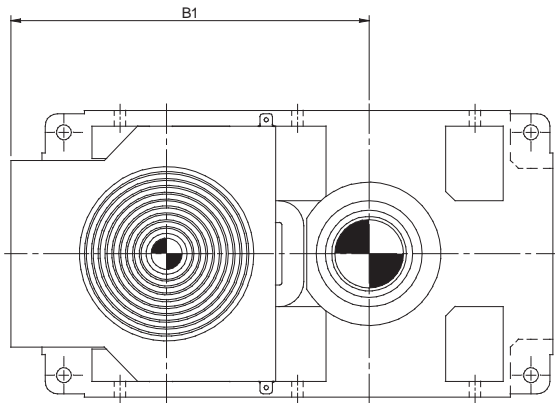

#### Double Reduction

Unit Size	B1	F1	F2	H1	H2	P	W3 (Useable shaft extension)
G14	585	225	452	200	63	315	108
G15	625	225	452	200	63	315	108
G16	766	281	581	245	85	370	108
G17	821	281	581	245	85	370	108
G18	1005	361	758	304	110	480	135
G19	1070	361	758	304	110	480	135
G21	1333	428	961	358	155	560	155
G22	1373	428	961	358	155	560	155

#### Triple and Quadruple Reduction

Unit Size	B1	F1	F2	H1	H2	P	W3 (Useable shaft extension)
G14	Not Available						
G15	Not Available						
G16	766	268	471	245	85	340	78
G17	821	268	471	245	85	340	78
G18	1005	350	623	304	110	440	110
G19	1070	350	623	304	110	440	110
G21	1333	428	803	358	155	540	135
G22	1373	428	803	358	155	540	135

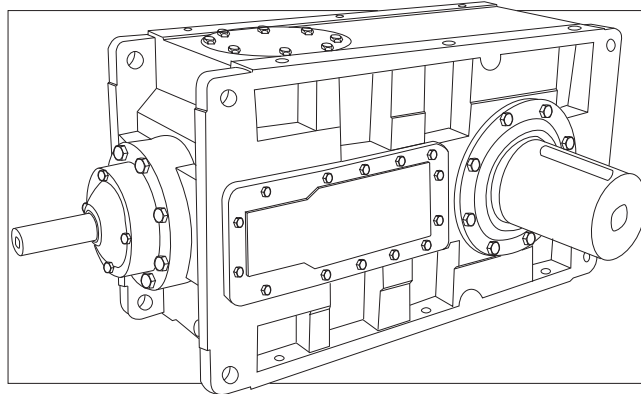

## RIGHT ANGLE UNITS

<u>Contents</u>	<u>Page No</u>
Moments of Inertia _____	39
Exact Ratios _____	40
Mechanical Ratings - Input Power / Output Torque _____	41 - 45
Thermal Ratings _____	46
Dimension Sheets - Speed Reducers _____	47 - 53

# SERIES G

## MOMENTS OF INERTIA RIGHT ANGLE SHAFTS

### MOMENTS OF INERTIA (Kg cm<sup>2</sup>) Referred to Input Shaft

#### RIGHT ANGLE UNITS - without fans

NOMINAL RATIO COLUMN ENTRY	RIGHT ANGLE SHAFT UNITS - SIZE								
	G14	G15	G16	G17	G18	G19	G21	G22	
	6	7	8						
8.0	610	-	2100	-	10900	-	-	-	TRIPLE REDUCTION
9.0	565	-	2060	-	10350	-	31200	-	
10.	540	-	1940	-	9630	-	29000	31600	
11.	515	-	1830	-	9210	-	27000	29400	
12.	495	565	1740	2110	9040	10180	25400	27400	
14.	475	540	1660	1960	8710	9650	23900	25800	
16.	460	515	1580	1840	8240	9410	22600	24300	
18.	445	490	1515	1740	8140	9000	21400	22900	
20.	435	470	1505	1640	7870	8460	20400	21700	
22.	115	455	430	1560	1875	8320	19000	20700	
25.	110	440	412	1545	1835	8010	7900	20200	
28.	105	120	393	450	1755	1980	7570	8070	
32.	100	115	374	430	1645	1920	7260	7713	
36.	96	110	360	411	1620	1825	7010	7370	
40.	93	105	348	391	1555	1695	6800	7100	
45.	50	100	187	376	780	1660	6690	6860	
50.	45	95	180	364	750	1590	3040	6740	
56.	43	50	177	196	740	830	2940	3080	
63.	41	45	171	189	715	775	2860	2980	
71.	-	44	435	186	1520	760	2820	2890	
80.	-	42	435	179	1500	730	7500	2840	
90.	-	-	110	440	420	1530	7420	7930	
100	-	-	105	435	410	1510	1610	7900	
112	-	-	105	110	394	430	1580	1790	
125	-	-	95	107	371	425	1570	1760	
140	-	-	95	106	360	397	1460	1750	
160	-	-	95	96	348	370	1450	1570	
180	-	-	46	95	187	360	1440	1550	
200	-	-	42	94	178	348	725	1545	
225	-	-	42	47	175	188	680	800	
250	-	-	41	42	172	178	670	720	
280	-	-	-	42	-	176	670	715	
315	-	-	-	42	-	173	-	710	

#### RIGHT ANGLE UNITS - with fans

If fan cooling is required the inertia of the fan must be added to the table above.

#### MOMENTS OF INERTIA of fans (Kg cm<sup>2</sup>)

	G14/G15	G16/G17	G18/G19	G21
TRIPLE REDUCTION	284	739	2365	4906

$GD^2$  (Kg cm<sup>2</sup>) = 4 x Moment of Inertia (Kg cm<sup>2</sup>)

# SERIES G

## EXACT RATIOS

### RIGHT ANGLE SHAFTS

#### EXACT RATIOS - RIGHT ANGLE UNITS

##### Triple Reduction

Nominal Ratio Column Entry	RIGHT ANGLE SHAFT UNITS - SIZE								
	6   7   8	G14	G15	G16	G17	G18	G19	G21	G22
8.0		7.691	-	8.095	-	7.842	-	-	-
9.0		8.863	-	8.755	-	8.663	-	9.127	-
10.		9.774	-	9.584	-	9.939	-	10.11	10.194
11.		10.816	-	10.937	-	11.08	-	11.434	11.291
12.		12.018	12.338	12.312	12.323	12.109	12.464	12.529	12.77
14.		13.42	13.653	13.718	14.062	13.586	13.893	14.041	13.993
16.		15.077	15.17	15.675	15.83	15.868	15.184	15.828	15.682
18.		17.065	16.94	17.807	17.637	17.474	17.037	17.973	17.678
20.		19.495	19.031	19.225	20.154	19.817	19.898	20.594	20.073
22.		21.775	21.541	21.756	22.894	22.636	21.912	22.136	23.001
25.		24.195	24.609	24.492	24.718	24.738	24.85	25.597	24.723
28.		27.017	27.487	27.288	27.972	27.757	28.384	28.686	28.589
32.		30.353	30.541	31.182	31.49	32.419	31.021	32.337	32.039
36.		34.356	34.104	35.422	35.084	35.7	34.806	36.718	36.117
40.		39.249	38.315	38.243	40.091	40.487	40.652	42.073	41.01
45.		41.605	43.368	43.244	45.543	42.83	44.767	45.223	46.991
50.		46.743	49.544	49.417	49.17	50.024	50.769	52.335	50.509
56.		52.907	52.518	56.136	55.6	55.087	53.708	59.426	58.452
63.		60.442	59.003	60.606	63.536	62.474	62.729	68.092	66.372
71.		-	66.784	-	72.174	-	69.078	73.19	76.051
80.		-	76.295	-	77.922	-	78.34	-	81.745

##### Quadruple Reduction

Nominal Ratio Column Entry	RIGHT ANGLE SHAFT UNITS - SIZE								
	6   7   8	G14	G15	G16	G17	G18	G19	G21	G22
71.		-	-	73.432	-	68.805	-	-	-
80.		-	-	79.28	-	78.03	-	83.586	-
90.		-	-	89.584	94.412	88.634	86.279	89.844	93.356
100		-	-	101.765	101.931	97.661	97.847	102.173	100.345
112		-	-	109.869	115.18	110.755	111.207	117.073	114.115
125		-	-	130.142	130.84	124.29	122.463	125.838	130.757
140		-	-	147.837	141.26	136.87	138.883	149.034	140.546
160		-	-	159.611	167.326	155.221	155.855	170.768	166.453
180		-	-	169.192	190.077	175.521	171.63	183.552	190.728
200		-	-	200.412	205.214	196.97	194.643	194.176	205.007
225		-	-	227.661	217.533	216.906	220.098	229.968	216.872
250		-	-	245.792	257.672	245.99	246.994	263.505	256.847
280		-	-	-	292.708	-	271.994	283.223	294.304
315		-	-	-	316.018	-	308.463	-	316.338

# SERIES G

## RIGHT ANGLE SHAFT MECHANICAL RATINGS AT 1750 RPM INPUT

NOMINAL RATIO	NOMINAL OUTPUT SPEED rev / min	CAPACITY	RIGHT ANGLE SHAFT UNITS - SIZE							
			G14	G15	G16	G17	G18	G19	G21	G22
8.0	219	Input Power - kW	196	-	417	-	<b>925</b>	-	-	-
		Output Torque - Nm	7920	-	17800	-	<b>38600</b>	-	-	-
9.0	194	Input Power - kW	196	-	417	-	<b>925</b>	-	<b>1825</b>	-
		Output Torque - Nm	9130	-	19300	-	<b>42600</b>	-	<b>88500</b>	-
10.	175	Input Power - kW	196	-	417	-	<b>925</b>	-	<b>1825</b>	<b>1825</b>
		Output Torque - Nm	10100	-	21100	-	<b>48900</b>	-	<b>98000</b>	<b>99300</b>
11.	156	Input Power - kW	190	-	417	-	<b>925</b>	-	<b>1825</b>	<b>1825</b>
		Output Torque - Nm	10800	-	24000	-	<b>54400</b>	-	<b>111000</b>	<b>110000</b>
12.	140	Input Power - kW	173	196	393	417	<b>913</b>	<b>925</b>	<b>1809</b>	<b>1825</b>
		Output Torque - Nm	11000	12700	25500	27100	<b>58600</b>	<b>61300</b>	<b>120000</b>	<b>124000</b>
14.	125	Input Power - kW	157	189	354	417	<b>815</b>	<b>925</b>	<b>1710</b>	<b>1800</b>
		Output Torque - Nm	11000	13600	25500	30900	<b>58600</b>	<b>68200</b>	<b>127000</b>	<b>135000</b>
16.	109	Input Power - kW	141	171	310	404	<b>699</b>	<b>925</b>	<b>1543</b>	<b>1700</b>
		Output Torque - Nm	11000	13700	25500	33700	<b>58600</b>	<b>74500</b>	<b>130000</b>	<b>142000</b>
18.	97	Input Power - kW	126	155	273	375	<b>635</b>	<b>863</b>	<b>1361</b>	<b>1560</b>
		Output Torque - Nm	11000	13800	25600	34800	<b>58600</b>	<b>77800</b>	<b>130000</b>	<b>147000</b>
20.	87.5	Input Power - kW	111	139	253	325	<b>561</b>	<b>750</b>	<b>1190</b>	<b>1410</b>
		Output Torque - Nm	11000	14000	25600	34400	<b>58600</b>	<b>79000</b>	<b>130000</b>	<b>150000</b>
22.	79.5	Input Power - kW	83.5	124	210	293	471	<b>682</b>	<b>1109</b>	<b>1300</b>
		Output Torque - Nm	9550	14000	24000	35300	56100	<b>79000</b>	<b>130000</b>	<b>158000</b>
25.	70	Input Power - kW	83.5	110	199	273	450	<b>603</b>	941	<b>1220</b>
		Output Torque - Nm	10600	14000	25600	35400	58600	<b>79000</b>	127000	<b>160000</b>
28.	62.5	Input Power - kW	78.1	83.5	179	210	402	471	857	936
		Output Torque - Nm	11000	13000	25600	31000	58600	70500	130000	142000
32.	54.7	Input Power - kW	70.2	82.5	157	210	344	457	761	901
		Output Torque - Nm	11000	13400	25600	34700	58600	74600	130000	153000
36.	48.6	Input Power - kW	62.6	77.1	138	189	313	432	671	844
		Output Torque - Nm	11000	13800	25600	35000	58600	79000	130000	161000
40.	43.8	Input Power - kW	55.2	69.3	128	167	276	371	587	745
		Output Torque - Nm	11000	14000	25600	35200	58600	79200	130000	161000
45.	38.9	Input Power - kW	50.2	61.8	113	148	261	337	546	652
		Output Torque - Nm	11000	14000	25600	35300	58600	79200	130000	161000
50.	35	Input Power - kW	45.6	54.5	99.2	138	224	297	473	607
		Output Torque - Nm	11000	14000	25600	35400	58600	79200	130000	161000
56.	31.3	Input Power - kW	40.7	50.2	87.4	118	203	265	418	491
		Output Torque - Nm	11000	14000	25600	34500	58600	74600	130000	150000
63.	27.8	Input Power - kW	35.9	45.1	81	106	180	241	365	465
		Output Torque - Nm	11000	14000	25600	35200	58600	79200	130000	161000
71.	24.6	Input Power - kW	-	40.2	67.6	93.5	165	219	340	406
		Output Torque - Nm	-	14000	25600	35300	58600	79200	130000	161000
80.	21.9	Input Power - kW	-	35.5	62.7	87	145	194	300	378
		Output Torque - Nm	-	14000	25600	35400	58600	79200	130000	161000
90.	19.4	Input Power - kW	-	-	55.4	72.3	126	166	278	334
		Output Torque - Nm	-	-	25600	35400	51500	74100	130000	162000
100	17.5	Input Power - kW	-	-	48.8	67.3	116	157	244	311
		Output Torque - Nm	-	-	25600	35400	53300	79300	130000	162000
112	15.6	Input Power - kW	-	-	45.2	58.3	102	126	213	273
		Output Torque - Nm	-	-	25600	34700	55600	72400	130000	162000
125	14	Input Power - kW	-	-	38.2	52.2	91.4	125	199	239
		Output Torque - Nm	-	-	25600	35400	57000	79300	130000	162000
140	12.5	Input Power - kW	-	-	33.7	48.6	83	111	168	222
		Output Torque - Nm	-	-	25600	35400	58600	79300	130000	162000
160	10.9	Input Power - kW	-	-	31.2	40.8	73.3	98.5	147	188
		Output Torque - Nm	-	-	25600	35200	58600	79300	130000	162000
180	9.7	Input Power - kW	-	-	26.7	36	64.8	89.5	137	164
		Output Torque - Nm	-	-	25600	35300	58600	79300	130000	162000
200	8.8	Input Power - kW	-	-	23.6	33.5	57.8	79	129	153
		Output Torque - Nm	-	-	25600	35400	58600	79300	130000	162000
225	7.8	Input Power - kW	-	-	21.9	26.7	52.5	69.9	109	145
		Output Torque - Nm	-	-	25600	30000	58600	79300	130000	162000
250	7	Input Power - kW	-	-	20.3	23.6	46.3	62.3	95	122
		Output Torque - Nm	-	-	25600	31500	58600	79300	130000	162000
280	6.3	Input Power - kW	-	-	-	23.4	-	56.6	89	107
		Output Torque - Nm	-	-	-	35300	-	79300	130000	162000
315	5.6	Input Power - kW	-	-	-	21.8	-	50	-	99.4
		Output Torque - Nm	-	-	-	35400	-	79300	-	162000

TRIPLE REDUCTION

QUADRUPLE REDUCTION

**Bold Text: Forced lubrication System Required**

# SERIES G

## RIGHT ANGLE SHAFT MECHANICAL RATINGS AT 1450 RPM INPUT

NOMINAL RATIO	NOMINAL OUTPUT SPEED rev / min	CAPACITY	RIGHT ANGLE SHAFT UNITS - SIZE							
			G14	G15	G16	G17	G18	G19	G21	G22
8.0	181	Input Power - kW	172	-	365	-	767	-	-	-
		Output Torque - Nm	8400	-	18900	-	38600	-	-	-
9.0	161	Input Power - kW	166	-	365	-	767	-	<b>1500</b>	-
		Output Torque - Nm	9400	-	20400	-	42600	-	<b>88000</b>	-
10.	145	Input Power - kW	162	-	365	-	767	-	<b>1500</b>	<b>1500</b>
		Output Torque - Nm	10100	-	22300	-	48800	-	<b>97000</b>	<b>98800</b>
11.	129	Input Power - kW	157	-	365	-	767	-	<b>1500</b>	<b>1500</b>
		Output Torque - Nm	10800	-	25400	-	54300	-	<b>110000</b>	<b>109000</b>
12.	116	Input Power - kW	144	162	327	373	757	767	<b>1500</b>	<b>1500</b>
		Output Torque - Nm	11000	12700	25500	29300	58600	61200	<b>120000</b>	<b>124000</b>
14.	104	Input Power - kW	130	156	293	365	676	767	<b>1432</b>	<b>1500</b>
		Output Torque - Nm	11000	13500	25600	32700	58600	68100	<b>129000</b>	<b>135000</b>
16.	91	Input Power - kW	117	142	257	345	580	767	<b>1273</b>	<b>1490</b>
		Output Torque - Nm	11000	13700	25600	34700	58600	74400	<b>130000</b>	<b>150000</b>
18.	81	Input Power - kW	104	128	227	311	527	726	<b>1123</b>	<b>1370</b>
		Output Torque - Nm	11000	13800	25600	34900	58600	79000	<b>130000</b>	<b>155000</b>
20.	72.5	Input Power - kW	91.9	115	210	275	466	623	<b>983</b>	<b>1230</b>
		Output Torque - Nm	11000	14000	25600	35200	58600	79000	<b>130000</b>	<b>158000</b>
22.	65.9	Input Power - kW	69.2	103	185	243	407	567	<b>915</b>	<b>1100</b>
		Output Torque - Nm	9550	14000	23700	35300	58500	79000	<b>130000</b>	<b>161000</b>
25.	58.0	Input Power - kW	69.2	82.5	165	226	373	501	776	<b>1020</b>
		Output Torque - Nm	10700	14000	25600	35400	58600	79100	127000	<b>161000</b>
28.	51.8	Input Power - kW	64.7	69.2	148	185	333	407	706	776
		Output Torque - Nm	11000	12000	25600	32700	58600	73300	130000	141000
32.	45.3	Input Power - kW	58.1	69.2	130	174	286	392	627	747
		Output Torque - Nm	11000	13400	25600	34700	58600	77100	130000	153000
36.	40.3	Input Power - kW	51.8	63.9	114	157	259	359	554	701
		Output Torque - Nm	11000	14000	25600	34900	58600	79100	130000	161000
40.	36.3	Input Power - kW	45.8	57.4	106	139	229	308	484	619
		Output Torque - Nm	11000	14000	25600	35200	58600	79200	130000	161000
45.	32.2	Input Power - kW	41.6	51.2	93.8	123	216	279	451	541
		Output Torque - Nm	11000	14000	25600	35300	58600	78200	130000	161000
50.	29.0	Input Power - kW	37.8	45.2	82.2	114	185	247	391	504
		Output Torque - Nm	11000	14000	25600	35400	58600	79200	130000	161000
56.	25.9	Input Power - kW	33.7	41.6	72.4	99.2	169	220	345	407
		Output Torque - Nm	11000	14000	25600	35000	58600	75000	130000	150000
63.	23.0	Input Power - kW	29.8	37.3	67.1	87.7	149	200	301	385
		Output Torque - Nm	11000	14000	25600	35200	58600	79200	130000	161000
71.	20.4	Input Power - kW	-	<b>33.3</b>	<b>56</b>	<b>77.5</b>	<b>136</b>	<b>182</b>	<b>280</b>	<b>337</b>
		Output Torque - Nm	-	<b>14000</b>	<b>25600</b>	<b>35200</b>	<b>58600</b>	<b>79200</b>	<b>130000</b>	<b>162000</b>
80.	18.1	Input Power - kW	-	<b>29.4</b>	<b>51.9</b>	<b>72.1</b>	<b>120</b>	<b>160</b>	<b>248</b>	<b>313</b>
		Output Torque - Nm	-	<b>14000</b>	<b>25600</b>	<b>35300</b>	<b>58600</b>	<b>79300</b>	<b>130000</b>	<b>162000</b>
90.	16.1	Input Power - kW	-	-	45.9	59.9	106	145	231	277
		Output Torque - Nm	-	-	25600	35300	54500	78400	130000	162000
100	14.5	Input Power - kW	-	-	40.4	55.8	96.2	130	202	258
		Output Torque - Nm	-	-	25600	35400	56400	79300	130000	162000
112	12.9	Input Power - kW	-	-	37.5	49	84.9	107	177	227
		Output Torque - Nm	-	-	25600	35200	58600	74300	130000	162000
125	11.6	Input Power - kW	-	-	31.7	43.2	75.7	104	165	198
		Output Torque - Nm	-	-	25600	35300	58600	79300	130000	162000
140	10.4	Input Power - kW	-	-	27.9	40.2	68.8	91.6	139	184
		Output Torque - Nm	-	-	25600	35400	58600	79300	130000	162000
160	9.1	Input Power - kW	-	-	25.9	33.8	60.7	81.7	122	156
		Output Torque - Nm	-	-	25600	35200	58600	79300	130000	162000
180	8.1	Input Power - kW	-	-	22.1	29.8	53.7	74.2	113	136
		Output Torque - Nm	-	-	25600	35300	58600	79300	130000	162000
200	7.3	Input Power - kW	-	-	19.6	27.8	47.9	65.5	107	127
		Output Torque - Nm	-	-	25600	35400	58600	79300	130000	162000
225	6.4	Input Power - kW	-	-	18.1	22.1	43.5	57.9	90	120
		Output Torque - Nm	-	-	25600	30000	58600	79300	130000	162000
250	5.8	Input Power - kW	-	-	16.8	19.6	38.4	51.6	79	101
		Output Torque - Nm	-	-	25600	31500	58600	79300	130000	162000
280	5.2	Input Power - kW	-	-	-	19.4	-	46.9	74	88.5
		Output Torque - Nm	-	-	-	35300	-	79300	130000	162000
315	4.6	Input Power - kW	-	-	-	18	-	41.4	-	82.4
		Output Torque - Nm	-	-	-	35400	-	79300	-	162000

TRIPLE REDUCTION

QUADRUPLE REDUCTION

**Bold Text: Forced lubrication System Required**

# SERIES G

## RIGHT ANGLE SHAFT MECHANICAL RATINGS AT 1160 RPM INPUT

NOMINAL RATIO	NOMINAL OUTPUT SPEED rev / min	CAPACITY	RIGHT ANGLE SHAFT UNITS - SIZE								
			G14	G15	G16	G17	G18	G19	G21	G22	
8.0	145	Input Power - kW	138	-	299	-	613	-	-	-	
		Output Torque - Nm	8450	-	19300	-	38500	-	-	-	
9.0	129	Input Power - kW	133	-	299	-	613	-	1200	-	
		Output Torque - Nm	9380	-	20800	-	42500	-	88000	-	
10.	116	Input Power - kW	130	-	299	-	613	-	1200	1200	
		Output Torque - Nm	10100	-	22700	-	48700	-	97000	98600	
11.	104	Input Power - kW	126	-	294	-	613	-	1200	1200	
		Output Torque - Nm	10800	-	25600	-	54200	-	110000	109000	
12.	93	Input Power - kW	115	130	262	299	607	613	1200	1200	
		Output Torque - Nm	11000	12700	25600	29300	58600	61100	120000	123000	
14.	83	Input Power - kW	104	125	235	297	541	613	1148	1200	
		Output Torque - Nm	11000	13500	25600	33200	58600	68000	129000	135000	
16.	73	Input Power - kW	93.4	114	206	276	464	613	1020	1200	
		Output Torque - Nm	11000	13700	25600	34700	58400	74300	130000	151000	
18.	64	Input Power - kW	83.3	103	182	249	422	583	900	1140	
		Output Torque - Nm	11000	13800	25600	35000	58600	79000	130000	161000	
20.	58.0	Input Power - kW	73.5	90.2	168	220	373	500	787	1000	
		Output Torque - Nm	11000	14000	25600	35200	58600	79100	130000	161000	
22.	52.7	Input Power - kW	55.3	82.2	148	195	326	454	733	878	
		Output Torque - Nm	9550	14000	25300	35300	58600	79100	130000	161000	
25.	46.4	Input Power - kW	55.3	72.6	132	181	299	401	621	818	
		Output Torque - Nm	10600	14000	25600	35400	58600	79100	127000	161000	
28.	41.4	Input Power - kW	51.8	55.3	119	148	267	326	566	621	
		Output Torque - Nm	11000	12000	25600	33000	58600	73300	130000	141000	
32.	36.3	Input Power - kW	46.5	55.3	104	139	228	314	503	598	
		Output Torque - Nm	11000	13400	25600	34700	58600	77100	130000	152000	
36.	32.2	Input Power - kW	41.5	51.1	91.6	126	208	287	444	562	
		Output Torque - Nm	11000	13800	25600	35000	58600	79200	130000	161000	
40.	29.0	Input Power - kW	36.6	45.9	84.9	111	183	246	388	496	
		Output Torque - Nm	11000	14000	25600	35200	58600	79200	130000	161000	
45.	25.8	Input Power - kW	33.3	40.9	75.1	98	173	224	361	434	
		Output Torque - Nm	11000	14000	25600	35300	58600	79200	130000	161000	
50.	23.2	Input Power - kW	30.2	36.2	65.8	91.2	148	197	313	404	
		Output Torque - Nm	11000	14000	25600	35400	58600	79200	130000	161000	
56.	20.7	Input Power - kW	27	33.2	57.9	79.4	135	176	276	325	
		Output Torque - Nm	11000	14000	25600	35000	58600	75000	130000	150000	
63.	18.4	Input Power - kW	23.8	29.9	53.7	70.2	119	160	241	308	
		Output Torque - Nm	11000	14000	25600	35200	58600	79200	130000	162000	
71.	16.3	Input Power - kW	-	26.6	44.8	62	109	145	224	269	
		Output Torque - Nm	-	14000	25600	35300	58600	79200	130000	162000	
80.	14.5	Input Power - kW	-	23.5	41.5	57.7	96.4	128	198	251	
		Output Torque - Nm	-	14000	25600	35400	58600	79300	130000	162000	
90.	12.9	Input Power - kW	-	-	36.7	47.9	84.7	118	185	222	
		Output Torque - Nm	-	-	25600	35300	58300	79300	130000	162000	
100	11.6	Input Power - kW	-	-	32.3	44.6	76.9	104	162	207	
		Output Torque - Nm	-	-	25600	35400	58600	79300	130000	162000	
112	10.4	Input Power - kW	-	-	30	39.2	67.9	88.7	141	181	
		Output Torque - Nm	-	-	25600	35200	58600	77000	130000	162000	
125	9.3	Input Power - kW	-	-	25.3	34.6	60.6	83	132	158	
		Output Torque - Nm	-	-	25600	35300	58600	79300	130000	162000	
140	8.3	Input Power - kW	-	-	22.3	32.2	55	73.3	111	147	
		Output Torque - Nm	-	-	25600	35400	58600	79300	130000	162000	
160	7.3	Input Power - kW	-	-	20.7	27	48.6	65.3	97	125	
		Output Torque - Nm	-	-	25600	35200	58600	79300	130000	162000	
180	6.4	Input Power - kW	-	-	17.7	23.9	42.9	59.3	91	109	
		Output Torque - Nm	-	-	23500	35300	58600	79300	130000	162000	
200	5.8	Input Power - kW	-	-	15.7	22.2	38.3	52.4	86	101	
		Output Torque - Nm	-	-	24500	35400	58600	79300	130000	162000	
225	5.2	Input Power - kW	-	-	14.5	17.7	34.8	46.3	72	95.8	
		Output Torque - Nm	-	-	25600	30000	58600	79300	130000	162000	
250	4.6	Input Power - kW	-	-	13.4	15.7	30.7	41.3	63	81	
		Output Torque - Nm	-	-	25600	31500	58600	79300	130000	162000	
280	4.1	Input Power - kW	-	-	-	15.5	-	37.5	59	70.7	
		Output Torque - Nm	-	-	-	35300	-	79300	130000	162000	
315	3.7	Input Power - kW	-	-	-	14.5	-	33.1	-	65.9	
		Output Torque - Nm	-	-	-	35400	-	79300	-	162000	

TRIPLE REDUCTION

QUADRUPLE REDUCTION



# SERIES G

## RIGHT ANGLE SHAFT MECHANICAL RATINGS AT 960 RPM INPUT

NOMINAL RATIO	NOMINAL OUTPUT SPEED rev / min	CAPACITY	RIGHT ANGLE SHAFT UNITS - SIZE								
			G14	G15	G16	G17	G18	G19	G21	G22	
8.0	120	Input Power - kW	114	-	247	-	507	-	-	-	TRIPLE REDUCTION
		Output Torque - Nm	8450	-	19200	-	38400	-	-	-	
9.0	107	Input Power - kW	110	-	247	-	507	-	995	-	
		Output Torque - Nm	9380	-	20800	-	42400	-	88000	-	
10.	96	Input Power - kW	107	-	247	-	507	-	995	996	
		Output Torque - Nm	10100	-	22700	-	48600	-	97000	98500	
11.	86	Input Power - kW	104	-	244	-	507	-	995	996	
		Output Torque - Nm	10800	-	25600	-	54200	-	110000	109000	
12.	77	Input Power - kW	95.1	107	217	247	503	507	995	996	
		Output Torque - Nm	11000	12700	25600	29200	58600	61000	120000	123000	
14.	69	Input Power - kW	86	103	195	246	448	507	950	996	
		Output Torque - Nm	11000	13500	25600	33200	58600	68000	129000	135000	
16.	60	Input Power - kW	77.3	94	171	229	385	507	845	996	
		Output Torque - Nm	11000	13700	25600	34700	58600	74200	130000	151000	
18.	53	Input Power - kW	68.9	85	150	206	350	482	746	943	
		Output Torque - Nm	11000	13800	25600	34900	58600	79100	130000	161000	
20.	48.0	Input Power - kW	60.8	76.3	139	182	309	414	652	832	
		Output Torque - Nm	11000	14000	25600	35200	58600	79100	130000	161000	
22.	43.6	Input Power - kW	45.8	68	122	161	269	376	607	728	
		Output Torque - Nm	9550	14000	25600	35300	58600	79100	130000	161000	
25.	38.4	Input Power - kW	45.8	60.1	109	150	247	332	514	678	
		Output Torque - Nm	10700	14000	25600	35400	58600	79200	126000	161000	
28.	34.3	Input Power - kW	42.8	45.8	98.2	122	221	269	469	514	
		Output Torque - Nm	11000	12000	25600	33000	58600	73500	130000	141000	
32.	30.0	Input Power - kW	38.5	45.8	86	115	189	260	417	495	
		Output Torque - Nm	11000	13400	25600	34700	58600	77100	130000	152000	
36.	26.7	Input Power - kW	34.3	42.3	75.8	104	172	238	368	466	
		Output Torque - Nm	11000	14000	25600	34900	58600	79200	130000	161000	
40.	24.0	Input Power - kW	30.3	38	70.2	91.8	152	204	321	411	
		Output Torque - Nm	11000	14000	25600	35200	58600	79200	130000	161000	
45.	21.3	Input Power - kW	27.5	33.9	62.1	81.1	143	185	300	359	
		Output Torque - Nm	10800	14000	25600	35300	58600	79200	130000	161000	
50.	19.2	Input Power - kW	25	29.9	54.4	75.5	123	163	259	334	
		Output Torque - Nm	10900	14000	25600	35400	58600	79300	130000	162000	
56.	17.1	Input Power - kW	22.3	27.5	48	65.7	112	145	228	269	
		Output Torque - Nm	11000	14000	25600	35000	58600	75000	130000	150000	
63.	15.2	Input Power - kW	19.7	24.7	44.4	58.1	98.5	132	200	255	
		Output Torque - Nm	11000	14000	25600	35200	58600	79200	130000	162000	
71.	13.5	Input Power - kW	-	22	37.1	51.3	90.4	120	185	223	
		Output Torque - Nm	-	14000	25600	35300	58600	79300	130000	162000	
80.	12.0	Input Power - kW	-	19.5	34.4	47.7	79.8	106	164	208	
		Output Torque - Nm	-	14000	25600	35400	58600	79300	130000	162000	
90.	10.7	Input Power - kW	-	-	30.4	39.7	70.1	97.5	153	184	
		Output Torque - Nm	-	-	25600	35300	58600	79300	130000	162000	
100	9.6	Input Power - kW	-	-	26.8	36.9	63.7	86.1	134	171	
		Output Torque - Nm	-	-	25600	35400	58600	79300	130000	162000	
112	8.6	Input Power - kW	-	-	24.8	32.4	56.2	75.6	117	150	
		Output Torque - Nm	-	-	25600	35300	58600	79300	130000	162000	
125	7.7	Input Power - kW	-	-	21	28.6	50.1	68.7	109	131	
		Output Torque - Nm	-	-	25600	35300	58600	79300	130000	162000	
140	6.9	Input Power - kW	-	-	18.5	26.6	45.5	60.6	92	122	
		Output Torque - Nm	-	-	25600	35400	58600	79300	130000	162000	
160	6.0	Input Power - kW	-	-	17.1	22.4	40.2	54.1	81	103	
		Output Torque - Nm	-	-	25600	35400	58600	79300	130000	162000	
180	5.3	Input Power - kW	-	-	14.6	19.7	35.5	49.1	75	90.2	
		Output Torque - Nm	-	-	23500	35400	58600	79300	130000	162000	
200	4.8	Input Power - kW	-	-	13	18.4	31.7	43.4	71	83.9	
		Output Torque - Nm	-	-	24500	35400	58600	79300	130000	162000	
225	4.3	Input Power - kW	-	-	12	14.6	28.8	38.3	60	79.3	
		Output Torque - Nm	-	-	25700	30000	58600	79300	130000	162000	
250	3.8	Input Power - kW	-	-	11.1	13	25.4	34.2	52	67	
		Output Torque - Nm	-	-	25700	31500	58600	79300	130000	162000	
280	3.4	Input Power - kW	-	-	-	12.8	-	31.1	49	58.8	
		Output Torque - Nm	-	-	-	35400	-	79300	130000	162000	
315	3.0	Input Power - kW	-	-	-	11.9	-	27.4	-	55.1	
		Output Torque - Nm	-	-	-	35400	-	79300	-	164000	

# SERIES G

## RIGHT ANGLE SHAFT MECHANICAL RATINGS AT 725 RPM INPUT

NOMINAL RATIO	NOM	M,P	RIGHT ANGLE SHAFT UNITS - SIZE								
			G14	G15	G16	G17	G18	G19	G21	G22	
8.0	91	Input Power - kW	86.4	-	187	-	383	-	-	-	TRIPLE REDUCTION
		Output Torque - Nm	8450	-	19200	-	38400	-	-	-	
9.0	81	Input Power - kW	83.2	-	187	-	383	-	752	-	
		Output Torque - Nm	9380	-	20800	-	42400	-	88000	-	
10.	73	Input Power - kW	81	-	187	-	383	-	752	752	
		Output Torque - Nm	10100	-	22700	-	48600	-	97000	98200	
11.	65	Input Power - kW	78.5	-	184	-	383	-	752	752	
		Output Torque - Nm	10800	-	25600	-	54100	-	110000	109000	
12.	58	Input Power - kW	71.8	81	164	187	380	383	752	752	
		Output Torque - Nm	11000	12700	25600	29200	58600	61000	120000	123000	
14.	52	Input Power - kW	65	78.1	147	186	339	383	720	752	
		Output Torque - Nm	11000	13500	25600	33200	58600	68000	129000	135000	
16.	45	Input Power - kW	58.4	71	129	173	291	383	639	752	
		Output Torque - Nm	11000	13700	25600	34700	58600	74100	130000	151000	
18.	40	Input Power - kW	52	64.2	114	156	264	365	564	714	
		Output Torque - Nm	11000	13800	25600	34900	58600	79100	130000	161000	
20.	36.3	Input Power - kW	45.9	57.6	105	138	233	313	493	630	
		Output Torque - Nm	11000	14000	25600	35200	58600	79200	130000	161000	
22.	33.0	Input Power - kW	34.6	51.4	92.4	122	204	285	459	551	
		Output Torque - Nm	9550	14000	25600	35300	58600	79200	130000	161000	
25.	29.0	Input Power - kW	34.6	45.4	82.6	113	187	251	389	514	
		Output Torque - Nm	10700	14000	25600	35400	58600	79200	126000	161000	
28.	25.9	Input Power - kW	32.4	34.6	74.2	92.4	167	204	355	389	
		Output Torque - Nm	11000	12000	25600	33000	58600	73500	130000	141000	
32.	22.7	Input Power - kW	29.1	34.6	65	87	143	196	315	374	
		Output Torque - Nm	11000	13400	25600	34700	58600	77100	130000	152000	
36.	20.1	Input Power - kW	25.9	32	57.3	78.4	130	180	278	353	
		Output Torque - Nm	11000	14000	25600	34900	58600	79200	130000	162000	
40.	18.1	Input Power - kW	22.9	28.7	53.1	69.4	114	154	243	311	
		Output Torque - Nm	11000	14000	25600	35200	58600	79300	130000	162000	
45.	16.1	Input Power - kW	20.8	25.6	46.9	61.3	108	140	226	272	
		Output Torque - Nm	10800	14000	25600	35300	58600	79300	130000	162000	
50.	14.5	Input Power - kW	18.9	22.6	41.1	57	92.7	123	195	253	
		Output Torque - Nm	11000	14000	25600	35400	58600	79300	130000	162000	
56.	12.9	Input Power - kW	16.8	20.8	36.2	49.6	84.2	110	172	203	
		Output Torque - Nm	11000	14000	25600	35000	58600	75000	130000	150000	
63.	11.5	Input Power - kW	14.9	18.7	33.6	43.9	74.4	100	150	193	
		Output Torque - Nm	11000	14000	25600	35200	58600	79300	130000	162000	
71.	10.2	Input Power - kW	-	16.6	28	38.7	68.2	90	140	168	
		Output Torque - Nm	-	14000	25600	35300	58600	79300	130000	162000	
80.	9.1	Input Power - kW	-	14.7	25.9	36	60.2	80.2	124	157	
		Output Torque - Nm	-	14000	25600	35400	58600	79300	130000	162000	
90.	8.1	Input Power - kW	-	-	22.9	29.9	52.9	73.6	115	139	
		Output Torque - Nm	-	-	25600	35300	58600	79300	130000	162000	
100	7.3	Input Power - kW	-	-	20.2	27.9	48.1	65	101	129	
		Output Torque - Nm	-	-	25600	35400	58600	79300	130000	162000	
112	6.5	Input Power - kW	-	-	18.7	24.5	42.4	57.1	88	113	
		Output Torque - Nm	-	-	25600	35300	58600	79300	130000	162000	
125	5.8	Input Power - kW	-	-	15.8	21.6	37.8	51.9	82	99	
		Output Torque - Nm	-	-	25600	35400	58600	79300	130000	162000	
140	5.2	Input Power - kW	-	-	13.9	20.1	34.4	45.8	70	92.2	
		Output Torque - Nm	-	-	25600	35400	58600	79300	130000	162000	
160	4.5	Input Power - kW	-	-	12.9	16.9	30.3	40.8	61	77.9	
		Output Torque - Nm	-	-	25600	35400	58600	79300	130000	162000	
180	4.0	Input Power - kW	-	-	11	14.9	26.8	37.1	57	68.1	
		Output Torque - Nm	-	-	23500	35400	58600	79300	130000	162000	
200	3.6	Input Power - kW	-	-	9.8	13.9	23.9	32.7	53	63.4	
		Output Torque - Nm	-	-	24500	35400	58600	79300	130000	162000	
225	3.2	Input Power - kW	-	-	9.1	11	21.7	29	45	59.9	
		Output Torque - Nm	-	-	25700	30000	58600	79300	130000	162000	
250	2.9	Input Power - kW	-	-	8.4	9.8	19.2	25.8	39	51.4	
		Output Torque - Nm	-	-	25700	31500	58600	79300	130000	164000	
280	2.6	Input Power - kW	-	-	-	9.7	-	23.5	37	44.9	
		Output Torque - Nm	-	-	-	35400	-	79300	130000	164000	
315	2.3	Input Power - kW	-	-	-	9	-	20.7	-	41.8	
		Output Torque - Nm	-	-	-	35400	-	79300	-	164000	

TRIPLE REDUCTION

QUADRUPLE REDUCTION

# SERIES G

## RIGHT ANGLE SHAFT THERMAL RATINGS

### Thermal Ratings kW

These thermal ratings assume the gear unit is in constant use working in an ambient temperature of 25°C (77°F) \* installed in a large indoor space at sea level.

These ratings must be adjusted for alternative operating and environment conditions refer to Thermal ratings and service factors on page 6.

\*maximum bulk oil temperature 95°C (203°F)

### Right Angle Shafts - Triple Reduction

Type of Cooling	Input Speed (rev/min)	Ratio	G1430	G1530	G1630	G1730	G1830	G1930	G2130	G2230
No Additional Cooling	1750	12:1	67	72	107	102	167	146	176	186
		25:1	50	58	89	87	139	124	154	166
		56:1	30	38	61	63	97	89	117	129
	1450	12:1	65	69	107	104	171	160	208	220
		25:1	50	56	90	89	145	138	185	198
		56:1	31	38	63	66	103	102	144	158
	1160	12:1	63	67	107	105	176	173	235	247
		25:1	49	55	90	91	150	150	211	225
		56:1	31	37	64	68	109	113	167	182
	960	12:1	62	65	107	106	178	180	252	265
		25:1	49	54	91	93	153	158	227	242
		56:1	31	37	65	70	112	120	182	198
Fan Cooling	1750	12:1	179	181	288	285	485	541	763	785
		25:1	154	161	261	264	441	502	722	748
		56:1	111	124	211	221	357	424	634	669
	1450	12:1	158	161	259	257	436	489	696	717
		25:1	135	142	234	237	395	452	656	682
		56:1	96	108	187	197	317	379	573	606
	1160	12:1	138	140	230	229	388	437	629	649
		25:1	117	123	207	211	350	403	591	616
		56:1	83	93	163	173	278	335	512	544
	960	12:1	124	126	210	210	354	400	581	601
		25:1	104	110	188	192	318	368	544	568
		56:1	73	83	147	157	251	304	469	500
Cooling Coil	1750	12:1	174	180	281	283	473	479	554	573
		25:1	149	160	255	261	430	441	516	539
		56:1	106	123	205	219	347	367	439	468
	1450	12:1	168	175	277	279	467	477	563	582
		25:1	145	156	251	258	425	441	526	549
		56:1	104	121	203	217	345	368	449	479
	1160	12:1	164	170	272	275	461	476	571	591
		25:1	141	151	248	255	421	440	534	558
		56:1	102	118	200	215	343	369	459	489
	960	12:1	161	166	269	273	458	475	576	596
		25:1	138	149	245	254	418	440	540	564
		56:1	101	116	199	214	341	370	465	495
Fan and Cooling Coil	1750	12:1	249	252	399	399	681	737	967	992
		25:1	221	231	371	376	633	695	923	953
		56:1	170	188	313	329	537	608	828	868
	1450	12:1	231	234	375	376	640	693	909	933
		25:1	204	214	348	354	594	652	866	895
		56:1	156	174	292	308	501	568	774	813
	1160	12:1	213	217	351	354	600	649	851	875
		25:1	188	198	325	332	556	611	809	838
		56:1	143	160	272	288	467	530	721	759
	960	12:1	201	206	335	338	572	619	810	834
		25:1	177	187	309	317	529	581	770	798
		56:1	134	150	258	274	444	503	684	721

### Right Angle Shafts - Quadruple Reduction

Type of Cooling	Input Speed (rev/min)	Ratio	G1440	G1540	G1640	G1740	G1840	G1940	G2140	G2240
No Additional Cooling	1750	100:1	-	-	62	61	83	75	92	94
		250:1	-	-	45	46	63	59	72	76
	1450	100:1	-	-	62	61	86	82	109	110
		250:1	-	-	45	47	67	66	88	92
	1160	100:1	-	-	61	62	89	88	123	124
		250:1	-	-	45	48	70	72	101	105
	960	100:1	-	-	61	62	90	92	132	133
		250:1	-	-	46	48	72	76	109	113

# SERIES G

## DIMENSIONS HORIZONTAL RIGHT ANGLE SHAFTS TRIPLE REDUCTION

### G 3 0 B Triple Reduction Right Angle Units Horizontal

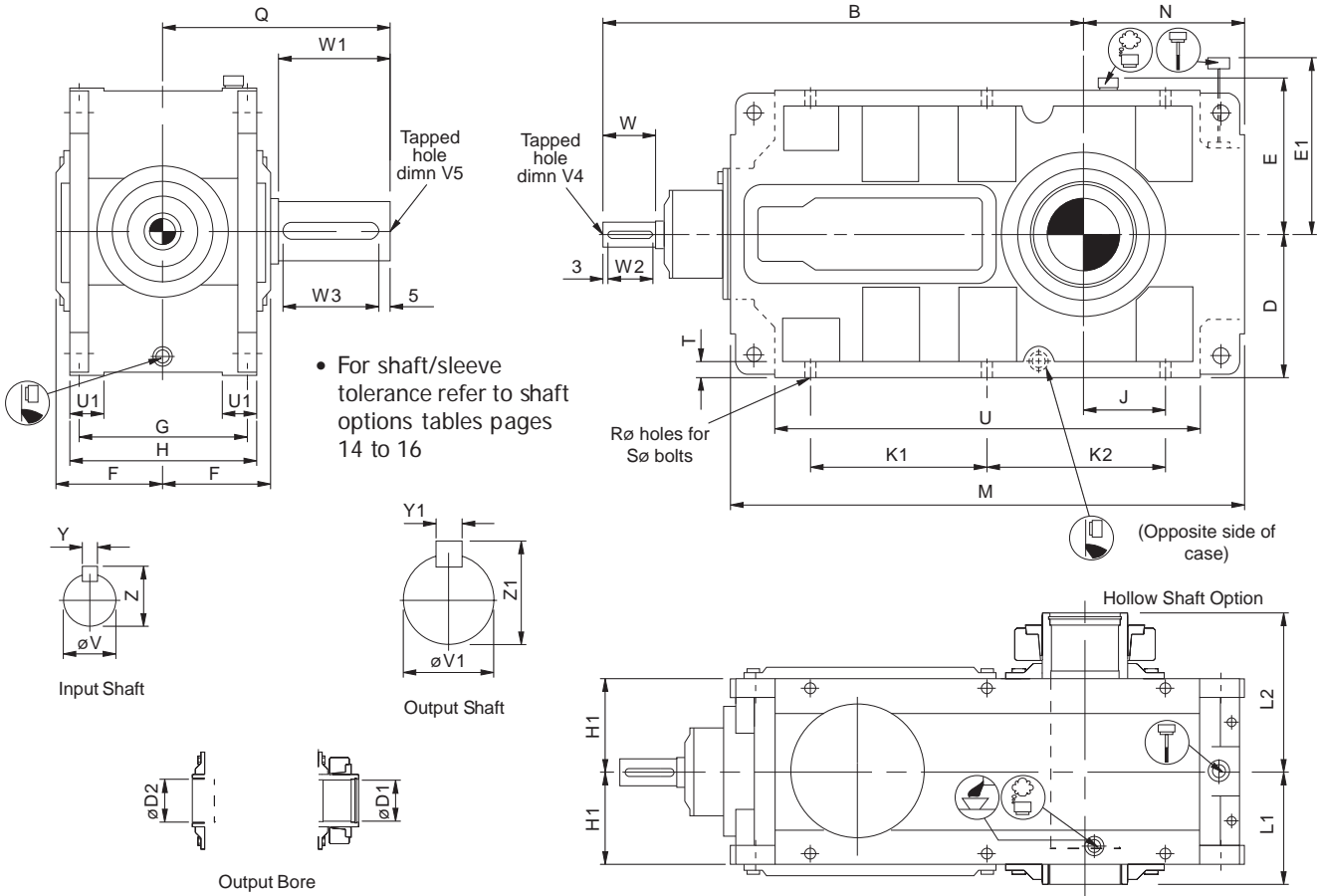

Unit Size	B	D	E	E1	F	G	H	H1	J	K1	K2	M	N	Q	R	S	T	U	U1
G14	720	230	250	370	177	265	300	150	170	285		820	295	360	18.5	6 x m16 x 60*	25	684	55
G15	760	230	250	370	177	265	300	150	130	285		820	255	370	18.5	6 x m16 x 60*	25	684	55
G16	940	300	335	515	225	330	380	190	225	385		1060	370	460	28	6 X m24 X 80*	30	898	70
G17	995	300	335	515	225	330	380	190	170	385		1060	315	480	28	6 x m24 x 80*	30	898	70
G18	1220	385	420	710	290	440	500	250	153	520	350	1240	338	600	33	6 x m30 x 100*	37	1036	90
G19	1285	385	420	710	290	440	500	250	220	500		1374	407	650	33	6 x m30 x 100*	40	1170	90
G21	1630	465	507	750	340	530	600	300	225	695	480	1655	465	700	39	6 x m36 x 100*	50	1380	120
G22	1670	465	507	750	340	530	600	300	245	745	490	1715	485	730	39	6 x m36 x 100*	50	1440	120

Unit Size	Input Shaft ●						Output Shaft ●						Output Bore ●			
	V	V4	W	W2	Y	Z	V1	V5	W1	W3	Y1	Z1	D1	D2	L1	L2
G14	38 k6	M12 x 32	100	90	10	41	110 m6	M30 x63	180	170	28	116	95	100	180	255
G15	38 k6	M12 x32	100	90	10	41	130 m6	M30 x63	190	180	32	137	110	115	180	260
G16	50 k6	M16 x 36	140	130	14	53.5	145 m6	M42 x81	230	220	36	153	125	130	230	325
G17	50 k6	M16 x 36	140	130	14	53.5	170 m6	M42 x81	250	240	40	179	145	150	230	340
G18	75 m6	M20 x 43	160	150	20	79.5	190 m6	M42 x81	300	290	45	200	160	170	300	410
G19	75 m6	M20 x 43	160	150	20	79.5	210 m6	M42 x81	350	340	50	221	170	180	300	430
G21	100 m6	M24 x 52	210	200	28	106	220 m6	M42 x81	350	340	50	231	210	220	350	500
G22	100 m6	M24 x 52	210	200	28	106	240 m6	M42 x81	380	340	56	252	230	240	350	515

# SERIES G

## DIMENSIONS VERTICAL RIGHT ANGLE SHAFTS TRIPLE REDUCTION

### G 3 0 R Triple Reduction Right Angle Units Vertical

- For shaft tolerance refer to shaft options tables pages 14 and 15

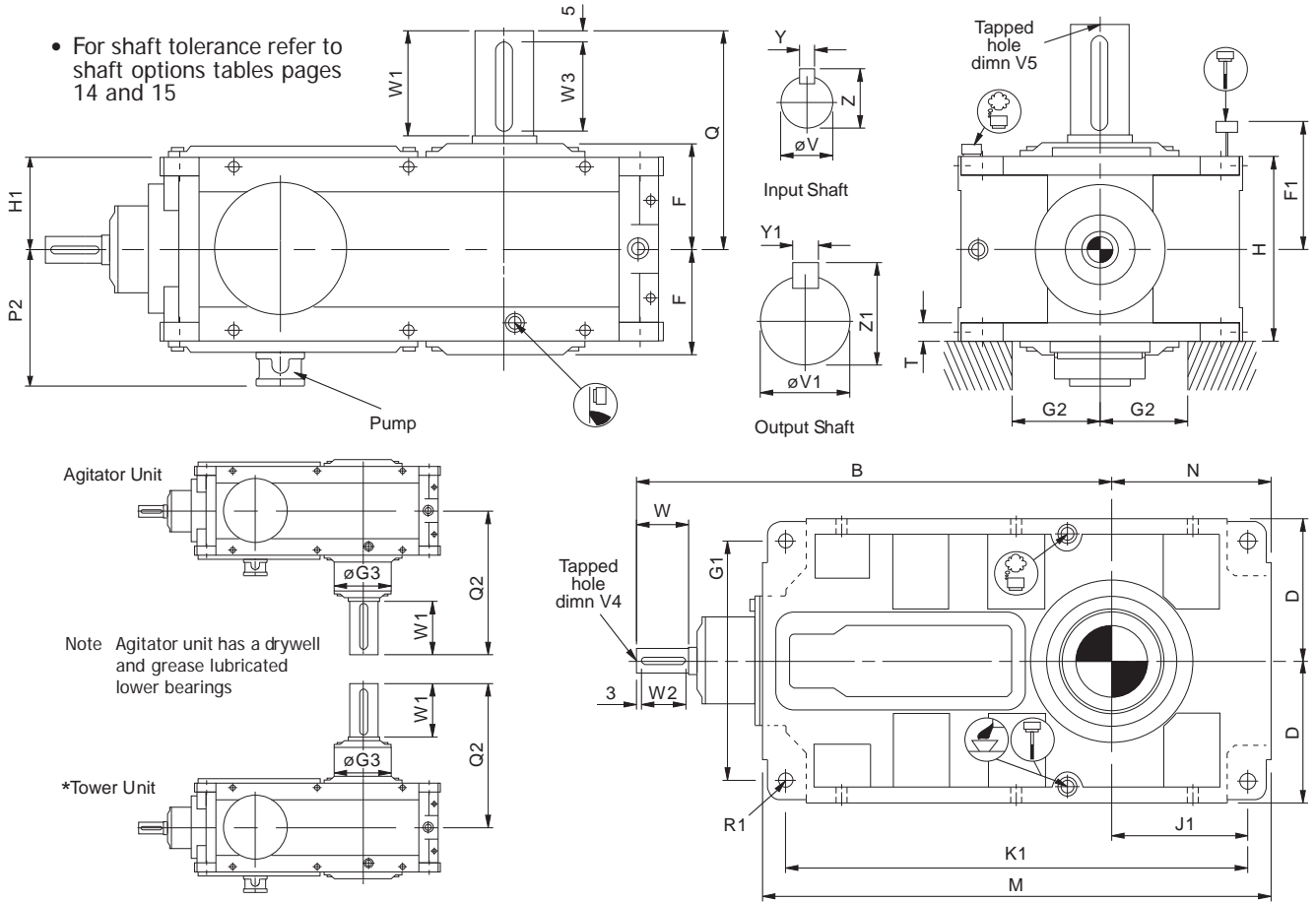

Unit Size	B	D	F	F1	G1	G2 (min)		G3	H	H1	J1	K1	M	N	P2	Q	Q2	R1	T
						No Fan	With Fan												
G14	720	230	177	390	390	135	155	230	300	150	260	750	820	295	236	360	475	4 x Ø24	30
G15	760	230	177	390	390	135	155	260	300	150	220	750	820	255	236	370	495	4 x Ø24	30
G16	940	300	225	515	506	175	205	300	380	190	325	970	1060	370	285	460	595	4 x Ø33	45
G17	995	300	225	515	506	175	205	340	380	190	270	970	1060	315	285	480	615	4 x Ø33	45
G18	1220	385	290	700	656	205	245	370	500	250	281	1126	1240	338	345	600	760	4 x Ø40	55
G19	1285	385	290	700	656	205	245	400	500	250	350	1260	1374	407	345	650	815	4 x Ø40	55
G21	1630	465	340	750	790	255	315	500	600	300	395	1515	1655	465	400	700	925	4 x Ø48	70
G22	1670	465	340	750	790	265	315	*	600	300	415	1575	1715	485	400	730	*	4 x Ø48	70

Unit Size	Input Shaft ●						Output Shaft ●					
	V	V4	W	W2	Y	Z	V1	V5	W1	W3	Y1	Z1
G14	38 k6	M12 x 32	100	90	10	41	110 m6	M30 x63	180	170	28	116
G15	38 k6	M12 x32	100	90	10	41	130 m6	M30 x63	190	180	32	137
G16	50 k6	M16 x 36	140	130	14	53.5	145 m6	M42 x81	230	220	36	153
G17	50 k6	M16 x 36	140	130	14	53.5	170 m6	M42 x81	250	240	40	179
G18	75 m6	M20 x 43	160	150	20	79.5	190 m6	M42 x81	300	290	45	200
G19	75 m6	M20 x 43	160	150	20	79.5	210 m6	M42 x81	350	340	50	221
G21	100 m6	M24 x 52	210	200	28	106	220 m6	M42 x81	350	340	50	231
G22	100 m6	M24 x 52	210	200	28	106	240 m6	M42 x81	380	340	56	252

\* = Contact Application Engineering

# SERIES G

## DIMENSIONS HORIZONTAL RIGHT ANGLE SHAFTS QUADRUPLE REDUCTION

### G 40 B Quadruple Reduction Right Angle Units Horizontal

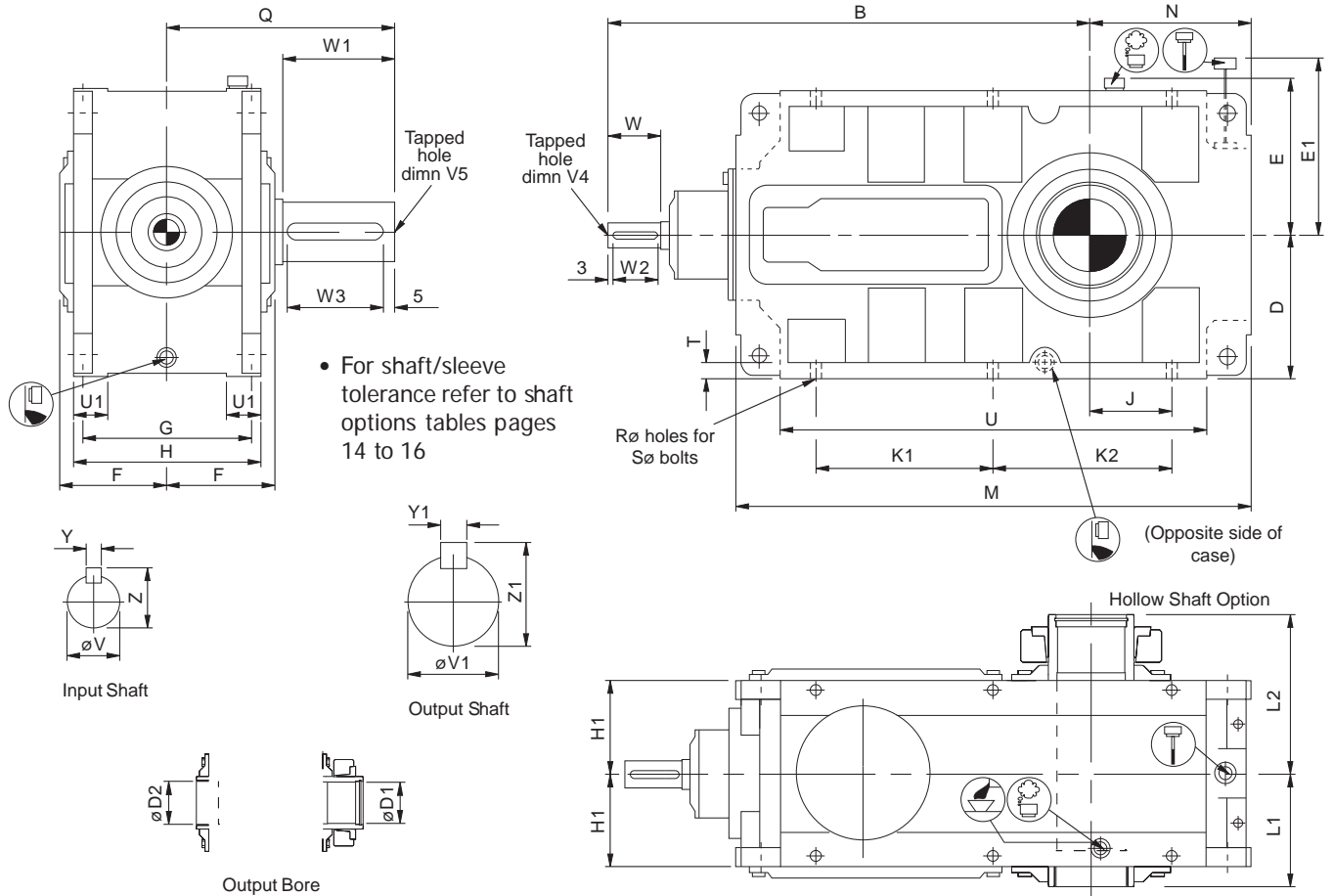

Unit Size	B	D	E	E1	F	G	H	H1	J	K1	K2	M	N	Q	R	S	T	U	U1
G16	965	300	335	515	225	330	380	190	225	385	1060	370	460	28	6 X m24 X 80*	30	898	70	
G17	1020	300	335	515	225	330	380	190	170	385	1060	315	480	28	6 x m24 x 80*	30	898	70	
G18	1265	385	420	710	290	440	500	250	153	520	350	1240	338	600	33	6 x m30 x 100*	37	1036	90
G19	1330	385	420	710	290	440	500	250	220	500	1374	407	650	33	6 x m30 x 100*	40	1170	90	
G21	1660	465	507	750	340	530	600	300	225	695	480	1655	465	700	39	6 x m36 x 100*	50	1380	120
G22	1700	465	507	750	340	530	600	300	245	745	490	1715	485	730	39	6 x m36 x 100*	50	1440	120

Unit Size	Input Shaft ●						Output Shaft ●						Output Bore ●			
	V	V4	W	W2	Y	Z	V1	V5	W1	W3	Y1	Z1	D1	D2	L1	L2
G16	38 k6	M12 x 32	100	90	10	41	145 m6	M42 x81	230	220	36	153	125	130	230	325
G17	38 k6	M12 x 32	100	90	10	41	170 m6	M42 x81	250	240	40	179	145	150	230	340
G18	50 k6	M16 x 36	140	130	14	53.5	190 m6	M42 x81	300	290	45	200	160	170	300	410
G19	50 k6	M16 x 36	140	130	14	53.5	210 m6	M42 x81	350	340	50	221	170	180	300	430
G21	75 m6	M20 x 43	160	150	20	79.5	220 m6	M42 x81	350	340	50	231	210	220	350	500
G22	75 m6	M20 x 43	160	150	20	79.5	240 m6	M42 x81	380	340	56	252	230	240	350	515

# SERIES G

## DIMENSIONS VERTICAL RIGHT ANGLE SHAFTS QUADRUPLE REDUCTION

### G 4 0 R Quadruple Reduction Right Angle Units Vertical

- For shaft tolerance refer to shaft options tables pages 14 and 15

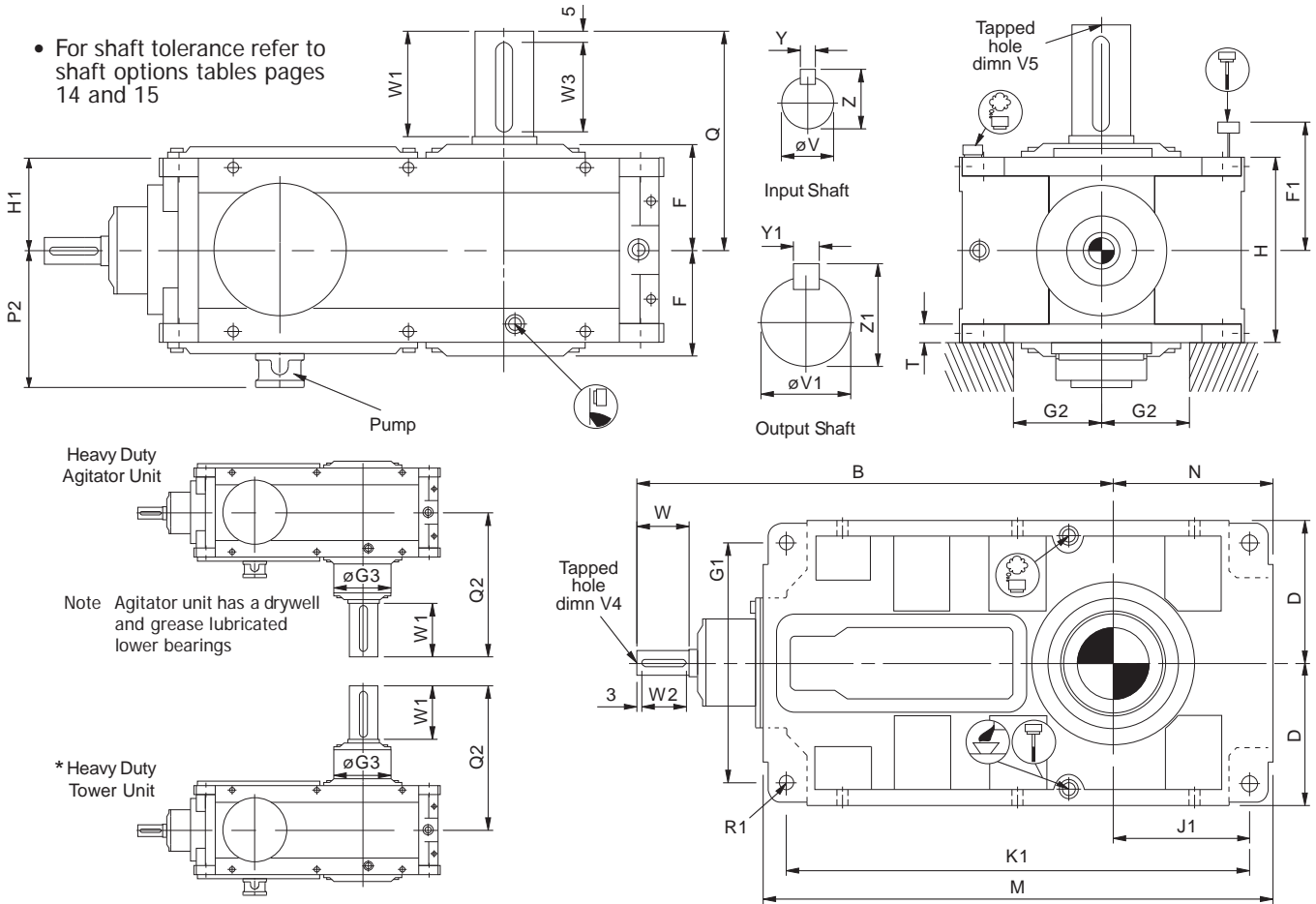

Unit Size	B	D	F	F1	G1	G2 (min)	G3	H	H1	J1	K1	M	N	P2	Q	Q2	R1	T
G16	965	300	225	515	506	175	300	380	190	325	970	1060	370	285	460	595	4 x Ø33	45
G17	1020	300	225	515	506	175	340	380	190	270	970	1060	315	285	480	615	4 x Ø33	45
G18	1265	385	290	700	656	205	370	500	250	281	1126	1240	338	345	600	760	4 x Ø40	55
G19	1330	385	290	700	656	205	400	500	250	350	1260	1374	407	345	650	815	4 x Ø40	55
G21	1660	465	340	750	790	255	500	600	300	395	1515	1655	465	400	700	925	4 x Ø48	70
G22	1700	465	340	750	790	265	*	600	300	415	1575	1715	485	400	730	*	4 x Ø48	70

Unit Size	Input Shaft ●						Output Shaft ●					
	V	V4	W	W2	Y	Z	V1	V5	W1	W3	Y1	Z1
G16	38 k6	M12 x 32	100	90	10	41	145 m6	M42 x81	230	220	36	153
G17	38 k6	M12 x 32	100	90	10	41	170 m6	M42 x81	250	240	40	179
G18	50 m6	M16 x 36	140	130	14	53.5	190 m6	M42 x81	300	290	45	200
G19	50 m6	M16 x 36	140	130	14	53.5	210 m6	M42 x81	350	340	50	221
G21	75 m6	M20 x 43	160	150	20	79.5	220 m6	M42 x81	350	340	50	231
G22	75 m6	M20 x 43	160	150	20	79.5	240 m6	M42 x81	380	340	56	252

\* = Contact Application Engineering

# SERIES G

## DIMENSIONS HORIZONTAL 'J' TYPE RIGHT ANGLE SHAFTS TRIPLE REDUCTION

### G

30

### B

### Triple Reduction 'J' Type Right Angle Units Horizontal

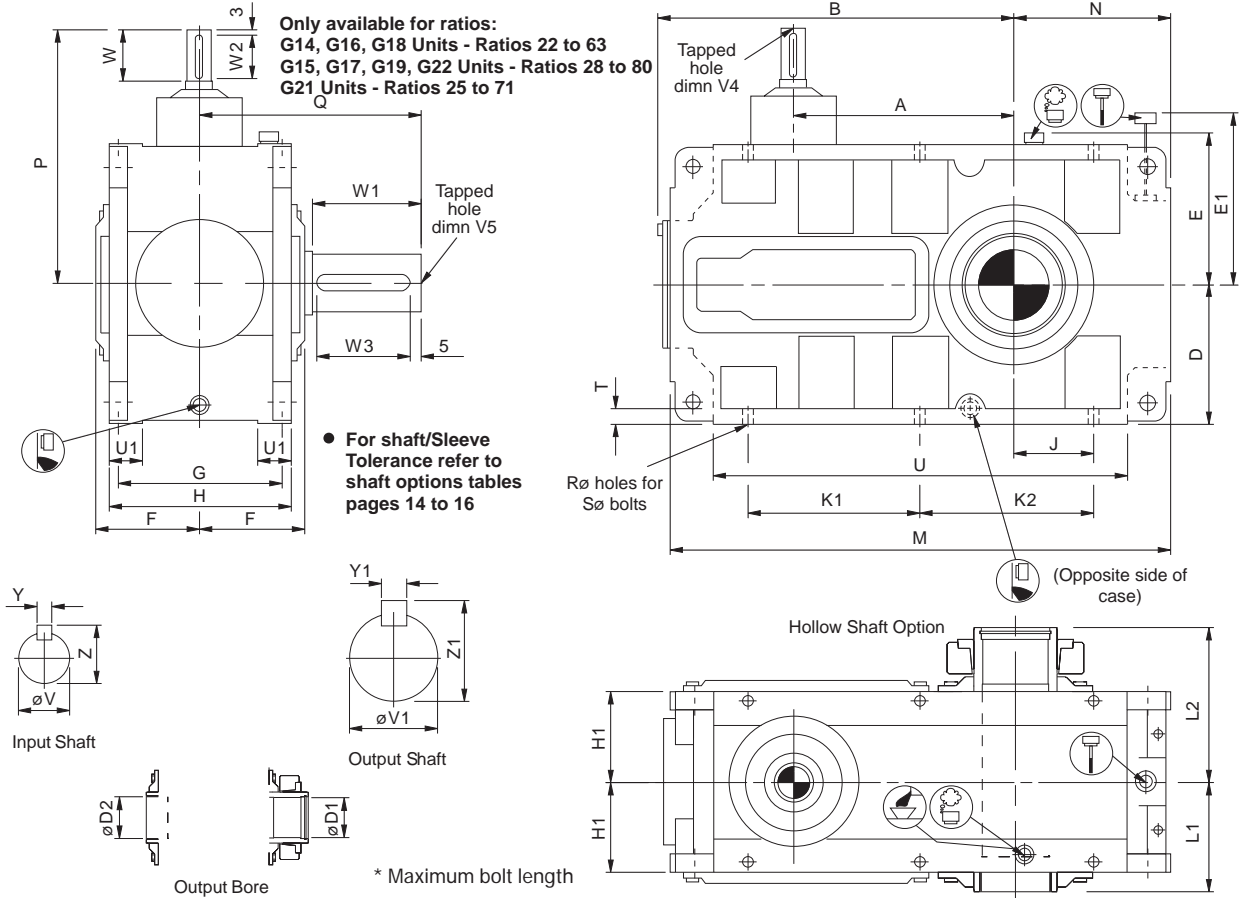

Unit Size	A	B	D	E	E1	F	G	H	H1	J	K1	K2	M	N	P	Q	R	S	T	U	U1
G14	325	554	230	250	370	177	265	300	150	170	285		820	295	395	360	18.5	6 x m16 x 60*	25	684	55
G15	365	594	230	250	370	177	265	300	150	130	285		820	255	395	370	18.5	6 x m16 x 60*	25	684	55
G16	430	728	300	335	515	225	330	380	190	225	385		1060	370	510	460	28	6 X m24 X 80*	30	898	70
G17	485	783	300	335	515	225	330	380	190	170	385		1060	315	510	480	28	6 x m24 x 80*	30	898	70
G18	570	953	385	420	710	290	440	500	250	153	520	350	1240	338	650	600	33	6 x m30 x 100*	37	1036	90
G19	635	1018	385	420	710	290	440	500	250	220	500		1374	407	650	650	33	6 x m30 x 100*	40	1170	90
G21	765	1240	465	507	750	340	530	600	300	225	695	480	1655	465	865	700	39	6 x m36 x 100*	50	1380	120
G22	805	1280	465	507	750	340	530	600	300	245	745	490	1715	485	865	730	39	6 x m36 x 100*	50	1440	120

Unit Size	Input Shaft ●						Output Shaft ●						Output Bore ●			
	V	V4	W	W2	Y	Z	V1	V5	W1	W3	Y1	Z1	D1	D2	L1	L2
G14	38 k6	M12 x 32	100	90	10	41	110 m6	M30 x63	180	170	28	116	95	100	180	255
G15	38 k6	M12 x 32	100	90	10	41	130 m6	M30 x63	190	180	32	137	110	115	180	260
G16	50 k6	M16 x 36	140	130	14	53.5	145 m6	M42 x81	230	220	36	153	125	130	230	325
G17	50 k6	M16 x 36	140	130	14	53.5	170 m6	M42 x81	250	240	40	179	145	150	230	340
G18	75 m6	M20 x 43	160	150	20	79.5	190 m6	M42 x81	300	290	45	200	160	170	300	410
G19	75 m6	M20 x 43	160	150	20	79.5	210 m6	M42 x81	350	340	50	221	170	180	300	430
G21	100 m6	M24 x 52	210	200	28	106	220 m6	M42 x81	350	340	50	231	210	220	350	500
G22	100 m6	M24 x 52	210	200	28	106	240 m6	M42 x81	380	340	56	252	230	240	350	515



# SERIES G

## DIMENSIONS VERTICAL 'J' TYPE RIGHT ANGLE SHAFTS TRIPLE REDUCTION

### G 3 0 R Triple Reduction 'J' Type Right Angle Units Vertical

Only available for ratios:  
 G14, G16, G18 Units - Ratios 22 to 63  
 G15, G17, G19, G22 Units - Ratios 28 to 80  
 G21 Units - Ratios 25 to 71

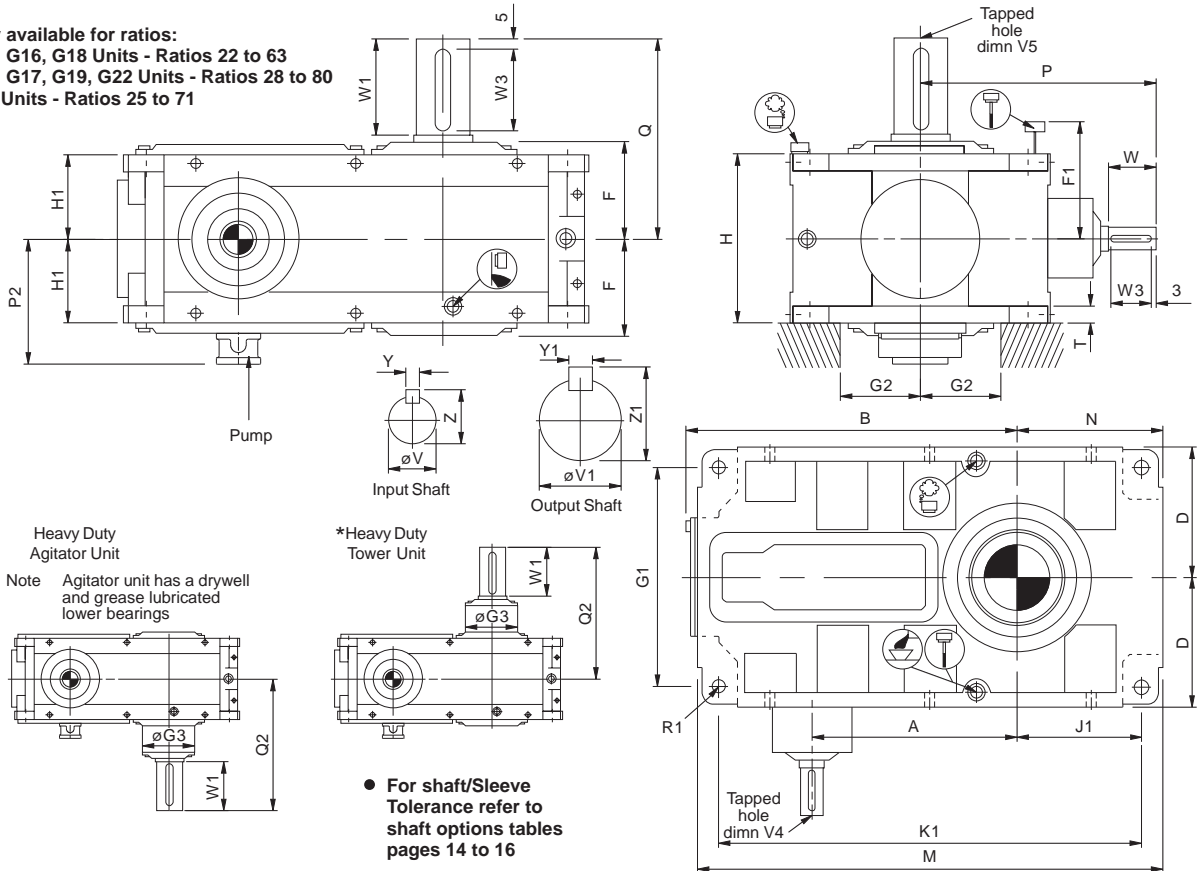

● For shaft/Sleeve Tolerance refer to shaft options tables pages 14 to 16

Unit Size	A	B	D	F	F1	G1	G2 (min)	G3	H	H1	J1	K1	M	N	P	P2	Q	Q2	R1	T
G14	325	554	230	177	390	390	135	230	300	150	260	750	820	295	395	236	360	475	4 x Ø24	30
G15	365	594	230	177	390	390	135	260	300	150	220	750	820	255	395	236	370	495	4 x Ø24	30
G16	430	728	300	225	515	506	175	300	380	190	325	970	1060	370	510	285	460	595	4 x Ø33	45
G17	485	783	300	225	515	506	175	340	380	190	270	970	1060	315	510	285	480	615	4 x Ø33	45
G18	570	953	385	290	700	656	205	370	500	250	281	1126	1240	338	650	345	600	760	4 x Ø40	55
G19	635	1018	385	290	700	656	205	400	500	250	350	1260	1374	407	650	345	650	815	4 x Ø40	55
G21	765	1240	465	340	750	790	255	500	600	300	395	1515	1655	465	865	400	700	925	4 x Ø48	70
G22	805	1280	465	340	750	790	265	*	600	300	415	1575	1715	485	865	400	730	*	4 x Ø48	70

Unit Size	Input Shaft ●						Output Shaft ●					
	V	V4	W	W2	Y	Z	V1	V5	W1	W3	Y1	Z1
G14	38 k6	M12 x 32	100	90	10	41	110 m6	M30 x63	180	170	28	116
G15	38 k6	M12 x 32	100	90	10	41	130 M6	M30 x63	190	180	32	137
G16	50 m6	M16 x 36	140	130	14	53.5	145 M6	M42 x81	230	220	36	153
G17	50 m6	M16 x 36	140	130	14	53.5	170 M6	M42 x81	250	240	40	179
G18	75 m6	M20 x 43	160	150	20	79.5	190 M6	M42 x81	300	290	45	200
G19	75 m6	M20 x 43	160	150	20	79.5	210 M6	M42 x81	350	340	50	221
G21	100 m6	M24 x 52	210	200	29	106	220 M6	M42 x81	350	340	50	231
G22	100 m6	M24 x 52	210	200	28	106	240 M6	M42 x81	380	340	56	252

\* = Contact Application Engineering

# SERIES G

## FAN COOLING DIMENSIONS

### RIGHT ANGLE SHAFTS

#### Right Angle Shaft Units with Mechanical Fans

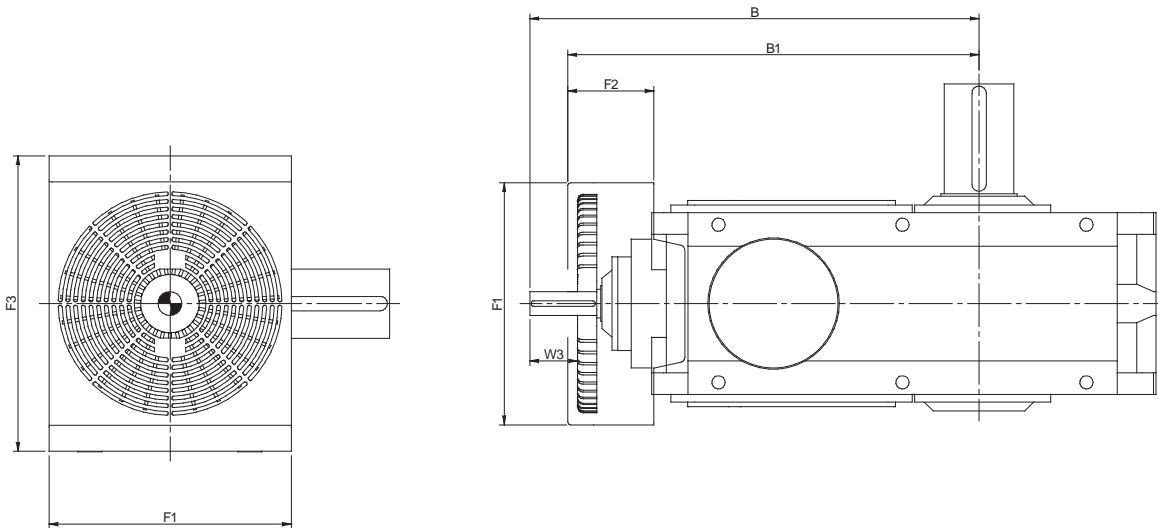

#### Triple Reduction Only

Unit Size	B	B1	F1	F2	F3	W3 (useable shaft extension)
G14	720	670	387	140	480	70
G15	760	710	387	140	480	70
G16	940	860	507	180	620	100
G17	995	915	507	180	620	100
G18	1220	1133	625	230	790	105
G19	1285	1198	625	230	790	105
G21	1630	1496	762	297	955	155
G22	1670	1536	762	297	955	155

# SERIES G

## HOLLOW OUTPUT SHAFT WITH SHRINK DISC

The gear unit is fitted with a 'shrink disc' device located on the hollow output shaft to provide a positive outer locking connection between gear unit and driven shaft. The 'shrink disc' is a friction device, without keys, which exerts an external clamping force on the hollow output shaft, thus establishing a mechanical shrink fit between the gear unit hollow shaft and driven shaft. 'Shrink disc' capacities have ample margins in dealing with transmitted torques and external loading imposed on gear units.

### WORKING PRINCIPLE

The 'shrink disc' consists of a locking collar, a tapered inner ring and locking screws. By tightening the locking screws, the locking collar and tapered inner ring are pulled together, exerting radial forces on the inner ring, thus creating a positive friction connection between hollow shaft and driven shaft.

As the tapered surfaces of locking collar and inner ring are lubricated with Molykote 321R or similar and the taper angle is not self locking, locking collar will not seize on the inner ring and can be released easily when removal is necessary.

When the shrink disc is clamped in position the high contact pressures between tapered surfaces and screw heads and their seatings ensure hermetic sealing and eliminate the possibility of fretting corrosion.

Unit Size	CUSTOMERS SHAFT								SHRINK DISC						
	ød1	ød2	ød3	ød4	I	I1	I2	K	Type	B	øD	øG	H	M	Torque Ta (Nm)
14	95 h6	100 h6	94.5	115	413	55	50	M24 x50	HSD 120-81-95	22	120	197	53	M12	121
15	110 h6	115 h6	109.5	130	418	60	60	M24 x50	HSD 140-81-110	22	140	230	58	M14	193
16	125 h6	130 h6	124.5	147	530	70	70	M24 x50	HSD 160-81-125	28	160	290	68	M16	295
17	145 h6	150 h6	144.5	167	545	90	90	M30 x60	HSD 180-81-145	28	180	320	85	M16	295
18	160 h6	170 g6	159.5	185	685	90	90	M30 x60	HSD 200-81-160	30	200	340	85	M16	295
19	170 g6	180 g6	169.5	195	705	105	105	M30 x60	HSD 220-81-170	30	220	370	103	M20	570
21	210 g6	220 g6	209.5	225	820	130	105	M30 x60	HSD 260-81-210	30	260	430	119	M20	570
22	230 g6	240 g6	229.5	235	835	145	105	M30 x60	HSD 280-81-230	30	280	460	132	M20	570

Unit Size	HOLLOW SHAFT							END PLATE							
	ød1	ød2	ød3	L	L1	L2	L3	C	C1	ød5	ød6	øK1	M crs	P	Circlip
14	95	100	96	415	180	255	276	20	10.0 9.8	99.75 99.5	78	26	55	M12	D1300-1000
15	110	115	111	420	180	260	276	20	10.0 9.8	114.75 114.50	90	26	65	M12	D1300-1150
16	125	130	126	533	230	325	348	25	12.0 11.8	129.75 129.50	103	26	70	M16	D1300-1300
17	145	150	147	548	230	340	348	25	12.0 11.8	149.75 149.50	120	33	85	M16	D1300-1500
18	160	170	162	688	300	410	442	25	12.0 11.8	169.75 169.5	135	33	100	M16	D1300-1700
19	170	180	172	708	300	430	442	25	12.0 11.8	184.75 184.50	150	33	110	M16	D1300-1850
21	210	220	212	824	350	500	510	28	14.0 13.8	219.75 219.50	170	33	130	M20	D1300-2200
22	230	240	232	839	350	515	535	28	14.0 13.8	239.75 239.50	190	33	150	M20	D1300-2400

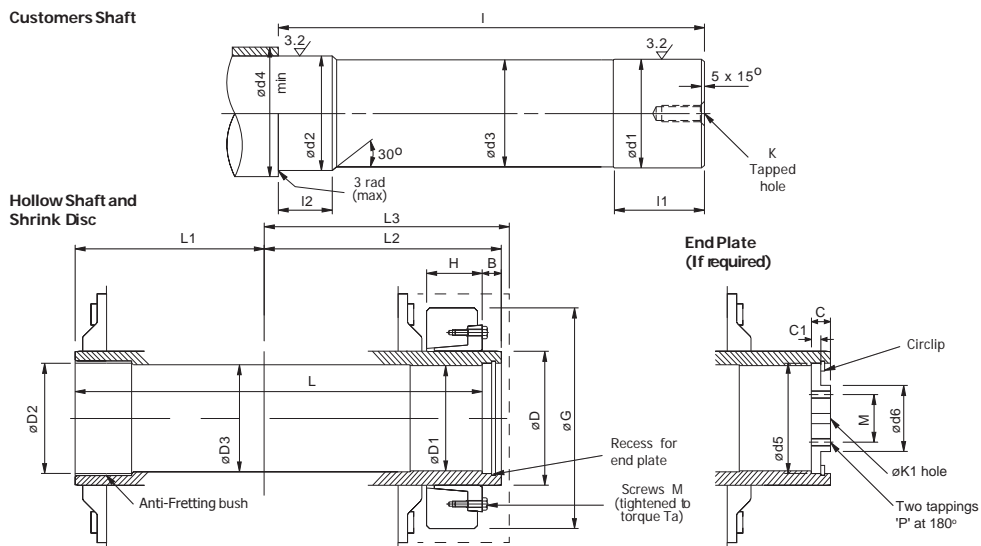

# SERIES G

## KEYED SLEEVES

### Column 10 Entry

Metric

K

Inch

W

Consult Application Engineering for dimensions of Inch sleeves

Customers Shaft

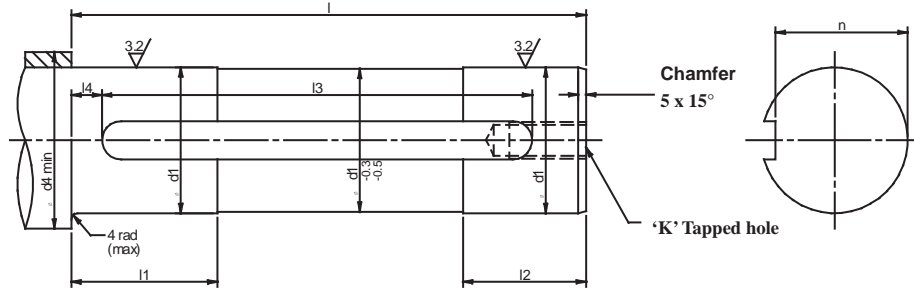

Hollow Shaft

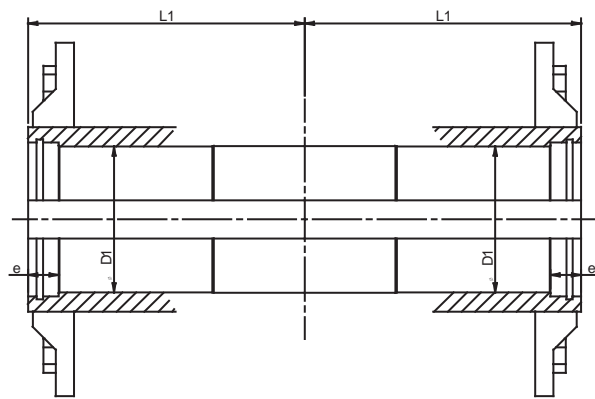

End Plate (If required)

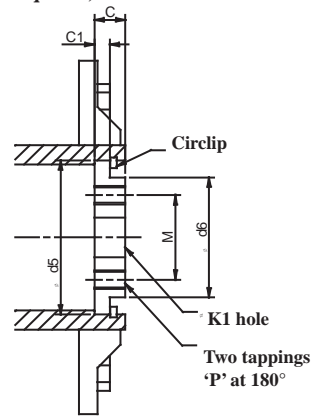

UNIT SIZE	CUSTOMERS SHAFT										
	Ød1	Ød4	l	l1	l2	l3 (min)	l4	m	n	k	Key Section (not supplied)
14	95 h6	115	335	95	80	280	20	25 (p9)	86.0 85.8	M24 x 50	25 x 14
15	110 h6	130	335	105	90	280	20	28 (p9)	100.0 99.8	M24 x 50	28 x 16
16	125 h6	147	430	120	100	360	25	32 (p9)	114.0 113.8	M24 x 50	32 x 18
17	145 h6	167	430	130	110	360	25	36 (p9)	133.0 132.7	M30 x 60	36 x 20
18	160 h6	192	570	145	125	520	25	40 (p9)	152.0 151.6	M30 x 60	40 x 22
19	180 g6	207	570	155	135	520	25	45 (p9)	165.0 164.7	M30 x 60	45 x 25
21	210 g6	225	670	165	145	610	30	50 (p9)	193.0 192.7	M30 x 60	50 x 28
22	230 g6	250	670	175	155	610	30	50 (p9)	213.0 212.7	M30 x 60	50 x 28

UNIT SIZE	HOLLOW SHAFT			END PLATE							
	ØD1	e	L1	C	C1	Ød5	Ød6	ØK1	M crs	P	Circlip
14	95 H7	20	180	20	10.0 9.8	99.75 99.50	78	26	55	M12	D1300-1000
15	110 H7	20	180	20	10.0 9.8	114.75 114.50	90	26	65	M12	D1300-1150
16	125 H7	22	230	25	12.0 11.8	129.75 129.50	103	26	70	M16	D1300-1300
17	145 H7	22	230	25	12.0 11.8	149.75 149.50	120	33	85	M16	D1300-1500
18	160 H7	22	300	25	12.0 11.8	169.75 169.50	135	33	100	M16	D1300-1700
19	180 H7	22	300	25	12.0 11.8	184.75 184.50	150	33	110	M16	D1300-1850
21	210 H7	26	350	28	14.0 13.8	219.75 219.50	170	33	130	M20	D1300-2200
22	230 H7	26	350	28	14.0 13.8	239.75 239.50	190	33	150	M20	D1300-2400

# SERIES G COOLING COIL CONNECTIONS

Cooling coils can be fitted to all unit types and handings.

Cooling coil connections for water inlet and outlet pipes are  $\varnothing 12\text{mm}$  on all sizes.

The protruding cooling coil pipe can be connected to customers pipe work via a suitable straight coupling.

**Water supply:** Cooling coils are suitable for fresh, brackish or sea water with flow in either direction. Connections are therefore interchangeable.

For best performance, the water supply should be at  $10^{\circ}\text{C}$  /  $12^{\circ}\text{C}$  temperature and at a flow rate of 5 litres / minute.

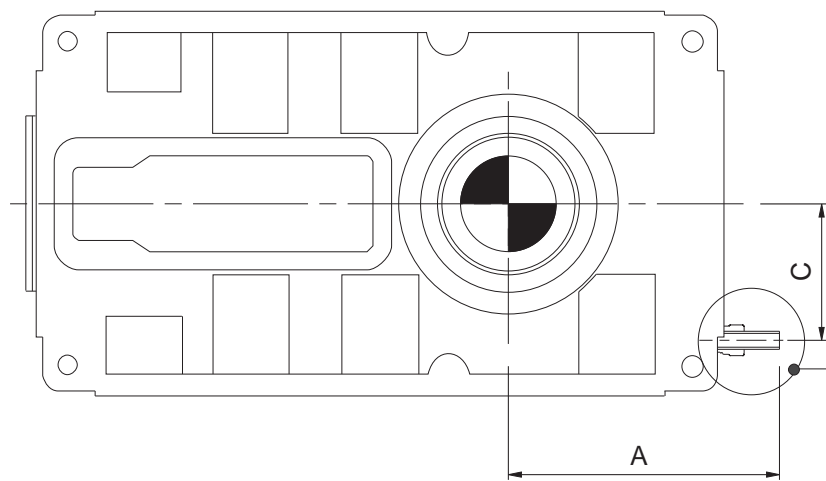
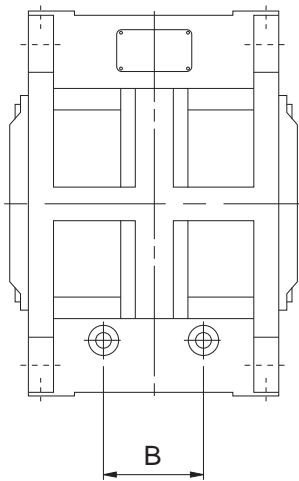

SIZE OF UNIT	A	B	C
14	310	120	163
15	270	120	163
16	370	150	220
17	315	150	220
18	315	200	285
19	385	200	285
21	400	200	355
22	420	200	355

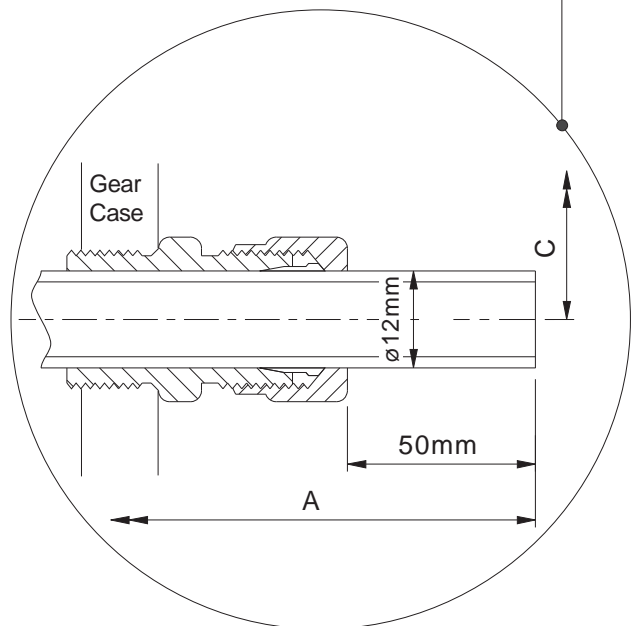

Externally mounted Backstops can be fitted to all Series G gear units, when required to operate in non-reversing drives. They are located on the helical pinion shaft and have adequate capacities to deal with full rated torques. All backstops are centrifugal lift off type. Changing the direction of locking rotation is a simple operation.

### Parallel Shaft Units

Column 16 entry, shaft rotation shown

3 Stage

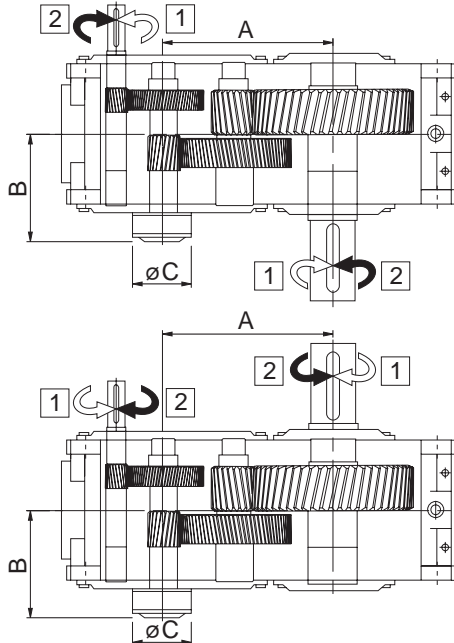

4 Stage

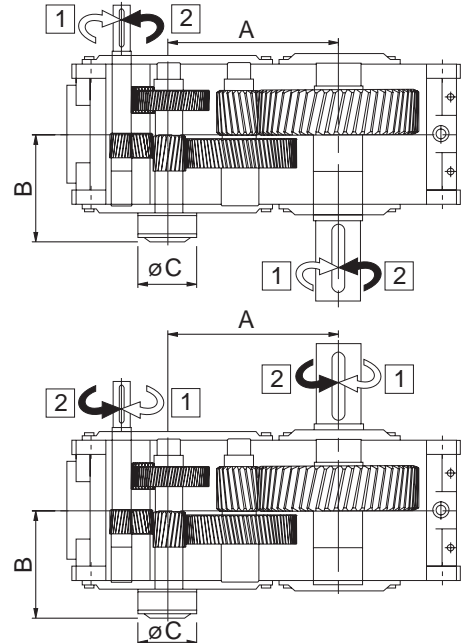

### Right Angle Shaft Units

Column 16 entry, shaft rotation shown

For right angle units, if backstop position is required at opposite side of unit to outputshaft, column 16 entry must be 3 or 4 (see page 14)

3 Stage

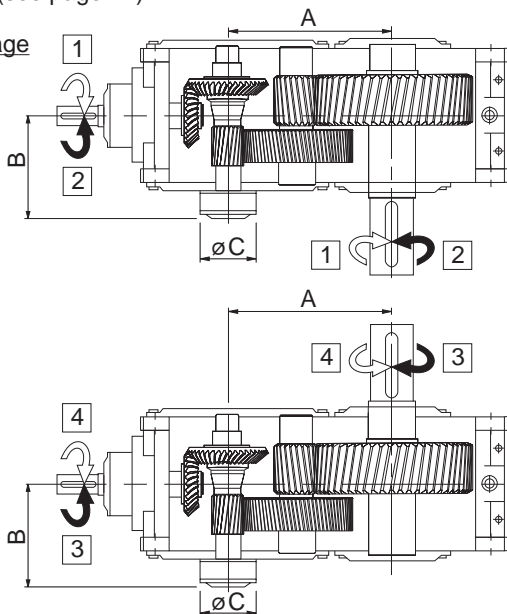

4 Stage

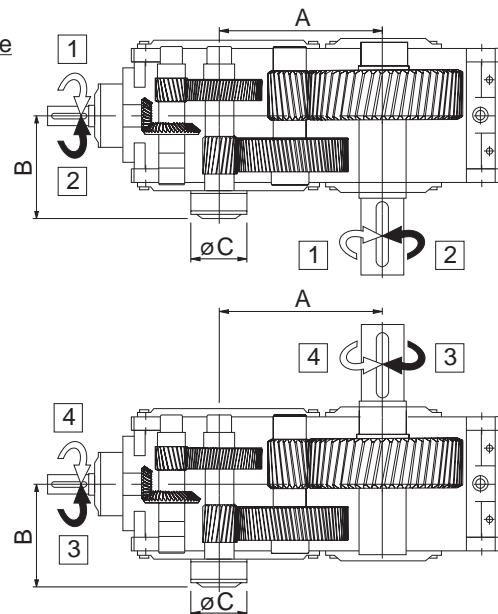

Unit Size	A	B	øC	Backstop
G14	325	275	175	85-40
G15	365			
G16	430	340	210	120-50
G17	485			
G18	570	433	290	170-63
G19	635			
G21	765	500	310	200-63
G22	805			

Note: Torque limiting backstops with controllable tension release can be fitted to all Series G units (for details consult our Application Engineers).

# SERIES G

## TORQUE ARM

Torque arms are available for all shaft mounted units with parallel or right angle shafts. They are supplied as optional extras and are secured to gear cases as shown below.

Torque arms must be secured to the chassis structure in a flexible mounting as indicated.

Shaft mounted units are designed to operate in the horizontal position. Reference must be made to our Application Engineers, with details, where units are required to operate in an inclined position.

### SHAFT MOUNTED UNITS FOR HIGH INERTIA DRIVE

When used on Traverse drives with high inertia driven loads, eg crane drives (slewing, long travel and cross travel) bogie drives and selected high inertia load roller table drives, it is recommended that shaft mounted units should be fitted with shock absorbing Torque Arms. Consult our Application Engineers with specific application details.

It is recommended that the torque arm is fitted on the side of the unit adjacent to the driven machine.

The torque arm must be flexibly mounted to the chassis structure

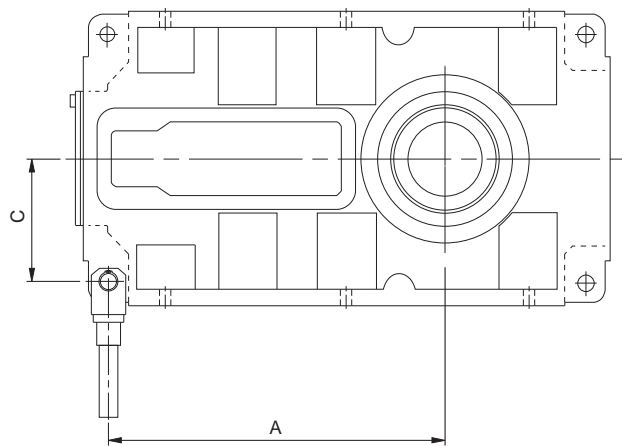
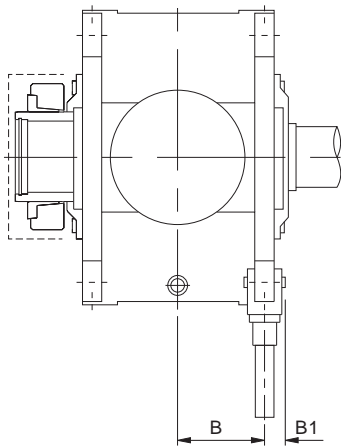
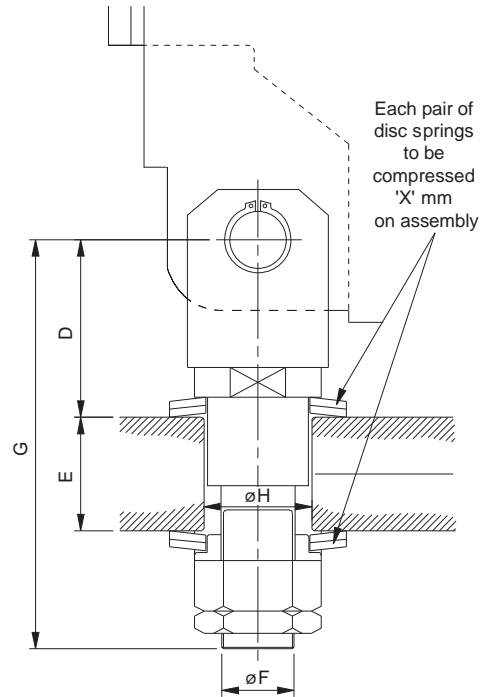

SIZE OF UNIT	A	B	B1	C	D	E		F	G	Disc Spring Ref	X	H
						MIN	MAX					
14	490	135	55	195	95	40	60	M30	207	80 x 41 x 4	1.1	41
15	530											
16	645	167	65	253	125	50	75	M36	262	100 x 51 x 6	1.1	52
17	700											
18	845	222	80	328	150	70	105	M48	336	125 x 71 x 6	1.7	72
19	910											
21 & 22	Contact our Application Engineers											

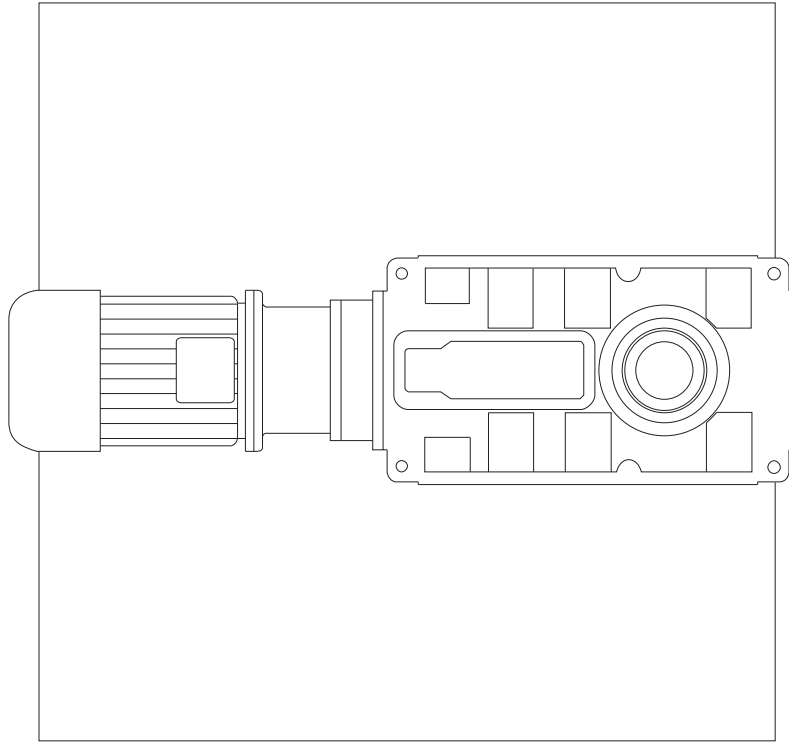

**MOTORISED  
SERIES G**



# SERIES G

## MOTORISED DIMENSIONS

### Parallel Shaft Units

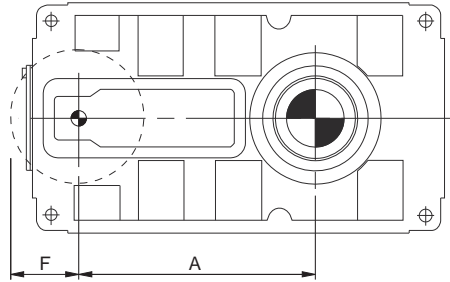
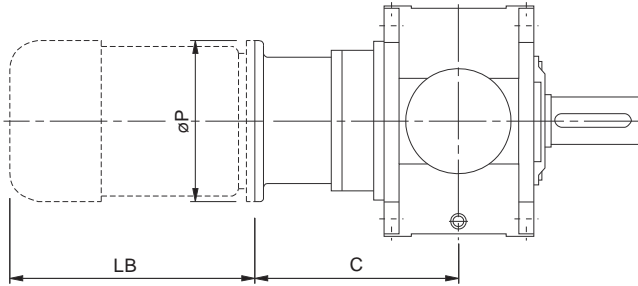

### Double Reduction

IEC Motors							
Unit Size	Motor Size	Column 13 Entry	A	C	F	LB (max)	ØP
G1420	200	D	325	428	229	651	400
	225	E	325	458	229	786	450
	250	F	325	458	275	839	550
G1520	200	D	365	428	229	651	400
	225	E	365	458	229	786	450
	250	F	365	458	275	839	550
G1620	250	F	430	513	298	839	550
	280	G	430	513	298	951	550
	315	H	430	543	330	1028	660
G1720	250	F	485	513	298	839	550
	280	G	485	513	298	951	550
	315	H	485	543	330	1028	660

NEMA Motors					
Motor Size	Column 13 Entry	C	F	LB (max)	ØP
324TC/326TC	R	445	229	657	339.7
364TC/365TC	S	460.9	229	785	339.7
404TC/405TC	T	495.8	229	839	352.4
324TC/326TC	R	445	229	657	339.7
364TC/365TC	S	460.9	229	785	339.7
404TC/405TC	T	495.8	229	839	352.4
364TC/365TC	S	515.9	383	785	339.7
404TC/405TC	T	550.8	383	839	352.4
444TC/445TC	U	582.6	383	951	352.4
364TC/365TC	S	515.9	383	785	339.7
404TC/405TC	T	550.8	383	839	352.4
444TC/445TC	U	582.6	383	951	352.4

### Triple and Quadruple Reduction

IEC Motors							
Unit Size	Motor Size	Column 13 Entry	A	C	F	LB (max)	ØP
G1430 / G1440	132	A	435	358	170	420	300
	160	B	435	388	175	540	350
	180	C	435	388	175	598	350
	200	D	435	388	200	651	400
	225	E	435	418	225	786	450
	250	F	435	418	275	839	550
G1530 / G1540 G1540	132	A	475	358	170	420	300
	160	B	475	388	175	540	350
	180	C	475	388	175	598	350
	200	D	475	388	200	651	400
	225	E	475	418	225	786	450
	250	F	475	418	275	839	550
G1630 / G1640	132	A	570	423	170	420	300
	160	B	570	453	175	540	350
	180	C	570	453	175	598	350
	200	D	570	453	200	651	400
	225	E	570	483	225	786	450
	250	F	570	483	275	839	550
	280	G	570	483	275	951	550
	315	H	570	513	330	1028	660
G1730 / G1740 G1740	132	A	625	423	170	420	300
	160	B	625	453	175	540	350
	180	C	625	453	175	598	350
	200	D	625	453	200	651	400
	225	E	625	483	225	786	450
	250	F	625	483	275	839	550
	280	G	625	483	275	951	550
	315	H	625	513	330	1028	660
G1830 / G1840	180	C	755	553	198	598	350
	200	D	755	553	200	651	400
	225	E	755	583	225	786	450
	250	F	755	583	275	839	550
	280	G	755	583	275	951	550
	315	H	755	613	330	1028	660
G1930 / G1940	180	C	820	553	198	598	350
	200	D	820	553	200	651	400
	225	E	820	583	225	786	450
	250	F	820	583	275	839	550
	280	G	820	583	275	951	550
	315	H	820	613	330	1028	660

NEMA Motors					
Motor Size	Column 13 Entry	C	F	LB (max)	ØP
254TC/256TC	P	373.2	170	546	254
284TC/286TC	Q	389.1	170	605	285.8
324TC/326TC	R	405	170	657	339.7
364TC/365TC	S	420.9	170	785	339.7
404TC/405TC	T	455.8	177	839	352.4
254TC/256TC	P	373.2	170	546	254
284TC/286TC	Q	389.1	170	605	285.8
324TC/326TC	R	405	170	657	339.7
364TC/365TC	S	420.9	170	785	339.7
404TC/405TC	T	455.8	177	839	352.4
254TC/256TC	P	438.2	170	546	254
284TC/286TC	Q	454.1	170	605	285.8
324TC/326TC	R	470	170	657	339.7
364TC/365TC	S	485.9	170	785	339.7
404TC/405TC	T	520.8	177	839	352.4
444TC/445TC	U	552.6	213	951	425.5
254TC/256TC	P	438.2	170	546	254
284TC/286TC	Q	454.1	170	605	285.8
324TC/326TC	R	470	170	657	339.7
364TC/365TC	S	485.9	170	785	339.7
404TC/405TC	T	520.8	177	839	352.4
444TC/445TC	U	552.6	213	951	425.5
254TC/256TC	P	538.2	198	546	254
284TC/286TC	Q	554.1	198	605	285.8
324TC/326TC	R	570	198	657	339.7
364TC/365TC	S	585.9	198	785	339.7
404TC/405TC	T	620.8	198	839	352.4
444TC/445TC	U	652.6	213	951	425.5

## MOTORISED DIMENSIONS

### Right Angle Shaft Units

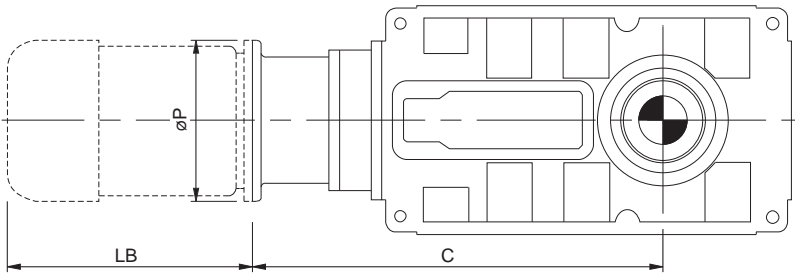

### Triple Reduction

IEC Motors					
Unit Size	Motor Size	Column 13 Entry	C	LB (max)	ØP
G1430	132	A	803	420	300
	160	B	833	540	350
	180	C	833	598	350
	200	D	833	651	400
	225	E	863	786	450
	250	F	863	839	550
	280	G	863	951	550
G1530	132	A	843	420	300
	160	B	873	540	350
	180	C	873	598	350
	200	D	873	651	400
	225	E	903	786	450
	250	F	903	839	550
	280	G	903	951	550
G1630	200	D	1053	651	400
	225	E	1083	786	450
	250	F	1083	839	550
	280	G	1083	951	550
	315	H	1113	1028	660
G1730	200	D	1108	651	400
	225	E	1138	786	450
	250	F	1138	839	550
	280	G	1138	951	550
	315	H	1168	1028	660
G1830	225	E	1363	786	450
	250	F	1363	839	550
	280	G	1363	951	550
	315	H	1393	1028	660
G1930	225	E	1428	786	450
	250	F	1428	839	550
	280	G	1428	951	550
	315	H	1458	1028	660

NEMA Motors					
Motor Size	Column 13 Entry	C	LB (max)	ØP	
254TC/256TC	P	818.3	546	254	
284TC/286TC	Q	834.1	605	285.8	
324TC/326TC	R	850	657	339.7	
364TC/365TC	S	865.9	785	339.7	
404TC/405TC	T	900.8	839	352.4	
254TC/256TC	P	858.3	546	254	
284TC/286TC	Q	874.1	605	285.8	
324TC/326TC	R	890	657	339.7	
364TC/365TC	S	905.9	785	339.7	
404TC/405TC	T	940.8	839	352.4	
324TC/326TC	R	1070	657	339.7	
364TC/365TC	S	1085.9	785	339.7	
404TC/405TC	T	1120.8	839	352.4	
444TC/445TC	U	1152.6	951	425.5	
324TC/326TC	R	1125.9	657	339.7	
364TC/365TC	S	1140.9	785	339.7	
404TC/405TC	T	1175.8	839	352.4	
444TC/445TC	U	1207.6	951	425.5	
364TC/365TC	S	1365.9	785	339.7	
404TC/405TC	T	1400.8	839	352.4	
444TC/445TC	U	1432.6	951	425.5	
364TC/365TC	S	1430.9	785	339.7	
404TC/405TC	T	1465.8	839	352.4	
444TC/445TC	U	1497.6	951	425.5	

### Quadruple Reduction

IEC Motors					
Unit Size	Motor Size	Column 13 Entry	C	LB (max)	ØP
G1640	132	A	1048	420	300
	160	B	1078	540	350
	180	C	1078	598	350
	200	D	1078	651	400
	225	E	1108	786	450
	250	F	1108	839	550
G1740	132	A	1113	420	300
	160	B	1133	540	350
	180	C	1133	598	350
	200	D	1133	651	400
	225	E	1163	786	450
	250	F	1163	839	550
G1840	160	B	1378	540	350
	180	C	1378	598	350
	200	D	1378	651	400
	225	E	1408	786	450
	250	F	1408	839	550
	280	G	1408	951	550
	315	H	1438	1028	660
G1940	160	B	1443	540	350
	180	C	1443	598	350
	200	D	1443	651	400
	225	E	1473	786	450
	250	F	1473	839	550
	280	G	1473	951	550
	315	H	1503	1028	660

NEMA Motors					
Motor Size	Column 13 Entry	C	LB (max)	ØP	
254TC/256TC	P	1063.3	546	254	
284TC/286TC	Q	1079.1	605	285.8	
324TC/326TC	R	1095	657	339.7	
364TC/365TC	S	1110.9	785	339.7	
404TC/405TC	T	1145.8	839	352.4	
254TC/256TC	P	1118.3	546	254	
284TC/286TC	Q	1134.1	605	285.8	
324TC/326TC	R	1150	657	339.7	
364TC/365TC	S	1165.9	785	339.7	
404TC/405TC	T	1200.8	839	352.4	
254TC/256TC	P	1363.3	546	254	
284TC/286TC	Q	1379.1	605	285.8	
324TC/326TC	R	1396	657	339.7	
364TC/365TC	S	1410.9	785	339.7	
404TC/405TC	T	1445.8	839	352.4	
444TC/445TC	U	1477.6	951	425.5	
254TC/256TC	P	1428.8	546	254	
284TC/286TC	Q	1444.1	605	285.8	
324TC/326TC	R	1461	657	339.7	
364TC/365TC	S	1475.9	785	339.7	
404TC/405TC	T	1510.8	839	352.4	
444TC/445TC	U	1542.6	951	425.5	

# SERIES G

## SHIPPING SPECIFICATION

### UNIT MASS (KG)

Gear Unit	No of Reductions	Output Shaft	Unit Size							
			14	15	16	17	18	19	21	22
Parallel Shaft	2 Stage	Standard	360	415	790	905	1530	1875	3150	3640
		Shaft Mount	340	385	755	855	1435	1755	2950	3370
		Agitator	400	455	840	980	1630	1995	3350	-
	3 Stage	Standard	375	430	805	920	1550	1895	3200	3690
		Shaft Mount	355	400	770	870	1455	1775	3000	3420
		Agitator	415	470	855	995	1650	2015	3400	-
	4 Stage	Standard	385	440	820	935	1580	1925	3250	3740
		Shaft Mount	365	405	785	885	1485	1805	3050	3470
		Agitator	425	480	870	1010	1680	2045	3450	-
Right Angle Shaft	3 Stage	Standard	395	450	840	940	1640	1985	3350	3840
		Shaft Mount	375	420	805	890	1545	1865	3150	3570
		Agitator	435	490	890	1015	1740	2105	3550	-
	4 Stage	Standard	-	-	840	940	1620	1965	3300	3790
		Shaft Mount	-	-	805	705	1525	1845	3100	3520
		Agitator	-	-	890	890	1720	2085	3500	-

Mass excludes: lubricant, cooling fans or coil.

### UNIT VOLUME (m<sup>3</sup>)

Gear Unit	No of Reductions	Output Shaft	Unit Size							
			14	15	16	17	18	19	21	22
Parallel Shaft	2 Stage	Standard	0.275	0.279	0.579	0.593	1.122	1.296	2.08	2.21
		Shaft Mount	0.202	0.202	0.418	0.418	0.811	0.895	1.76	1.84
		Agitator	0.309	0.316	0.636	0.649	1.233	1.421	2.35	-
	3 Stage	Standard	0.259	0.263	0.558	0.572	1.081	1.25	2.06	2.21
		Shaft Mount	0.185	0.185	0.397	0.397	0.769	0.849	1.72	1.80
		Agitator	0.293	0.301	0.616	0.629	1.193	1.377	2.32	-
	4 Stage	Standard	0.259	0.263	0.558	0.572	1.081	1.25	2.06	2.17
		Shaft Mount	0.185	0.185	0.397	0.397	0.769	0.849	1.72	1.80
		Agitator	0.293	0.301	0.616	0.629	1.193	1.377	2.32	-
Right Angle Shaft	3 Stage	Standard	0.262	0.266	0.57	0.586	1.116	1.28	2.12	2.18
		Shaft Mount	0.212	0.214	0.462	0.474	0.89	0.994	1.73	1.82
		Agitator	0.304	0.314	0.645	0.66	1.26	1.44	1.47	-
	4 Stage	Standard	-	-	0.581	0.598	1.148	1.314	2.15	2.21
		Shaft Mount	-	-	0.47	0.483	0.916	1.021	1.76	1.84
		Agitator	-	-	0.657	0.673	1.296	1.478	2.5	-



## IMPORTANT

### Product Safety Information

**General** - The following information is important in ensuring safety. It **must** be brought to the attention of personnel involved in the selection of the equipment, those responsible for the design of the machinery in which it is to be incorporated and those involved in its installation, use and maintenance.

The equipment will operate safely provided it is selected, installed, used and maintained properly. As with any power transmission equipment **proper precautions must** be taken as indicated in the following paragraphs, to ensure safety.

**Potential Hazards** - these are **not** necessarily listed in any order of severity as the degree of danger varies in individual circumstances. It is important therefore that the list is studied in its entirety:-

- 1) Fire/Explosion
  - (a) Oil mists and vapour are generated within gear units. It is therefore dangerous to use naked lights in the proximity of gearbox openings, due to the risk of fire or explosion.
  - (b) In the event of fire or serious overheating (over 300 °C), certain materials (rubber, plastics, etc.) may decompose and produce fumes. Care should be taken to avoid exposure to the fumes, and the remains of burned or overheated plastic/rubber materials should be handled with rubber gloves.
- 2) Guards - Rotating shafts and couplings must be guarded to eliminate the possibility of physical contact or entanglement of clothing. It should be of rigid construction and firmly secured.
- 3) Noise - High speed gearboxes and gearbox driven machinery may produce noise levels which are damaging to the hearing with prolonged exposure. Ear defenders should be provided for personnel in these circumstances. Reference should be made to the Department of Employment Code of Practice for reducing exposure of employed persons to noise.
- 4) Lifting - Where provided (on larger units) only the lifting points or eyebolts must be used for lifting operations (see maintenance manual or general arrangement drawing for lifting point positions). Failure to use the lifting points provided may result in personal injury and/or damage to the product or surrounding equipment. Keep clear of raised equipment.
- 5) Lubricants and Lubrication
  - (a) Prolonged contact with lubricants can be detrimental to the skin. The manufacturer's instruction must be followed when handling lubricants.
  - (b) The lubrication status of the equipment must be checked before commissioning. Read and carry out all instructions on the lubricant plate and in the installation and maintenance literature. Heed all warning tags. Failure to do so could result in mechanical damage and in extreme cases risk of injury to personnel.
- 6) Electrical Equipment - Observe hazard warnings on electrical equipment and isolate power before working on the gearbox or associated equipment, in order to prevent the machinery being started.
- 7) Installation, Maintenance and Storage
  - (a) In the event that equipment is to be held in storage, for a period exceeding 6 months, prior to installation or commissioning, application engineering must be consulted regarding special preservation requirements. Unless otherwise agreed, equipment must be stored in a building protected from extremes of temperature and humidity to prevent deterioration.  
The rotating components (gears and shafts) must be turned a few revolutions once a month (to prevent bearings brinelling).
  - (b) External gearbox components may be supplied with preservative materials applied, in the form of a "waxed" tape overwrap or wax film preservative. Gloves should be worn when removing these materials. The former can be removed manually, the latter using white spirit as a solvent.  
  
Preservatives applied to the internal parts of the gear units do not require removal prior to operation.
  - (c) Installation must be performed in accordance with the manufacturer's instructions and be undertaken by suitably qualified personnel.
  - (d) Before working on a gearbox or associated equipment, ensure that the load has been removed from the system to eliminate the possibility of any movement of the machinery and isolate power supply. Where necessary, provide mechanical means to ensure the machinery cannot move or rotate. Ensure removal of such devices after work is complete.
  - (e) Ensure the proper maintenance of gearboxes in operation. Use only the correct tools and approved spare parts for repair and maintenance. Consult the Maintenance Manual before dismantling or performing maintenance work.
- 8) Hot Surfaces and Lubricants
  - (a) During operation, gear units may become sufficiently hot to cause skin burns. Care must be taken to avoid accidental contact.
  - (b) After extended running the lubricant in gear units and lubrication systems may reach temperatures sufficient to cause burns. Allow equipment to cool before servicing or performing adjustments.
- 9) Selection and Design
  - (a) Where gear units provide a backstop facility, ensure that back-up systems are provided if failure of the backstop device would endanger personnel or result in damage.
  - (b) The driving and driven equipment must be correctly selected to ensure that the complete machinery installation will perform satisfactorily, avoiding system critical speeds, system torsional vibration, etc.
  - (c) The equipment must not be operated in an environment or at speeds, powers, torques or with external loads beyond those for which it was designed.
  - (d) As improvements in design are being made continually the contents of this catalogue are not to be regarded as binding in detail, and drawings and capacities are subject to alterations without notice.

The above guidance is based on the current state of knowledge and our best assessment of the potential hazards in the operation of the gear units.

Any further information or clarification required may be obtained by contacting an Application Engineer.

# CONTACT US

## AUSTRALIA

### **Radicon Transmission (Australia) PTY Ltd**

Australia  
Tel: +61 421 822 315

## EUROPE

### **Benzler TBA BV**

Jachthavenweg 2  
NL-5928 NT Venlo

Germany  
Tel: 0800 350 40 00  
Fax: 0800 350 40 01

Italy  
Tel: +39 02 824 3511

Netherlands & the rest of Europe  
Tel: +31 77 324 59 00  
Fax: +31 77 324 59 01

## DENMARK

### **Benzler Transmission A/S**

Dalager 1  
DK-2605 Brøndby,  
Denmark

Tel: +45 36 34 03 00  
Fax: +45 36 77 02 42

## FINLAND

### **Oy Benzler AB**

Vanha Talvitie 3C  
FI-00580 Helsingfors,  
Finland

Tel: +358 9 340 1716  
Fax: +358 10 296 2072

## INDIA

### **Elecon. Engineering Company Ltd.**

Anand Sojitra Road  
Vallabh Vidyanagar  
388120 Gujarat  
India

Tel: +91 2692 236513  
Fax: +91 2692 227484

## SWEDEN & NORWAY

### **AB Benzlers**

Porfyrgatan  
254 68 Helsingborg  
Sweden

Tel: +46 42 18 68 00  
Fax: +46 42 21 88 03

## THAILAND

### **Radicon Transmission (Thailand) Ltd**

700/43 Moo 6  
Amata Nakorn Industrial Estate  
Tumbol Klontumru  
Muang,  
Chonburi  
20000  
Thailand

Tel: +66 3845 9044  
Fax: +66 3821 3655

## UNITED KINGDOM

### **Radicon Transmission UK Ltd**

Unit J3  
Lowfields Business Park,  
Lowfields Way, Elland  
West Yorkshire, HX5 9DA

Tel: +44 1484 465 800  
Fax: +44 1484 465 801

## USA

### **Radicon Drive Systems, Inc.**

1599 Lunt Avenue  
Elk Grove Village  
Chicago  
Illinois  
60007  
USA

Tel: +1 847 593 9910  
Fax: +1 847 593 9950

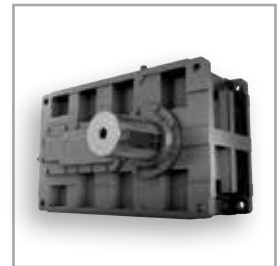
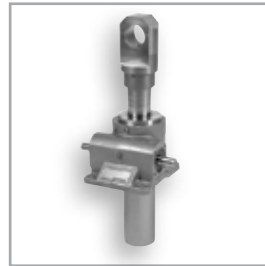

benzlers<sup>⚙️</sup>  
radicon<sup>⚙️</sup>

**Benzlers**

Denmark +45 36 340300  
Finland +358 9 3401716  
Germany +49 800 3504000  
Italy +39 02 824 3511  
Sweden +46 42 186800  
The Netherlands +31 77 3245900  
[www.benzlers.com](http://www.benzlers.com)

**Radicon**

Thailand +66 38459044  
United Kingdom +44 1484 465800  
USA +1 847 5939910  
[www.radicon.com](http://www.radicon.com)