

Precision Link Conveyors

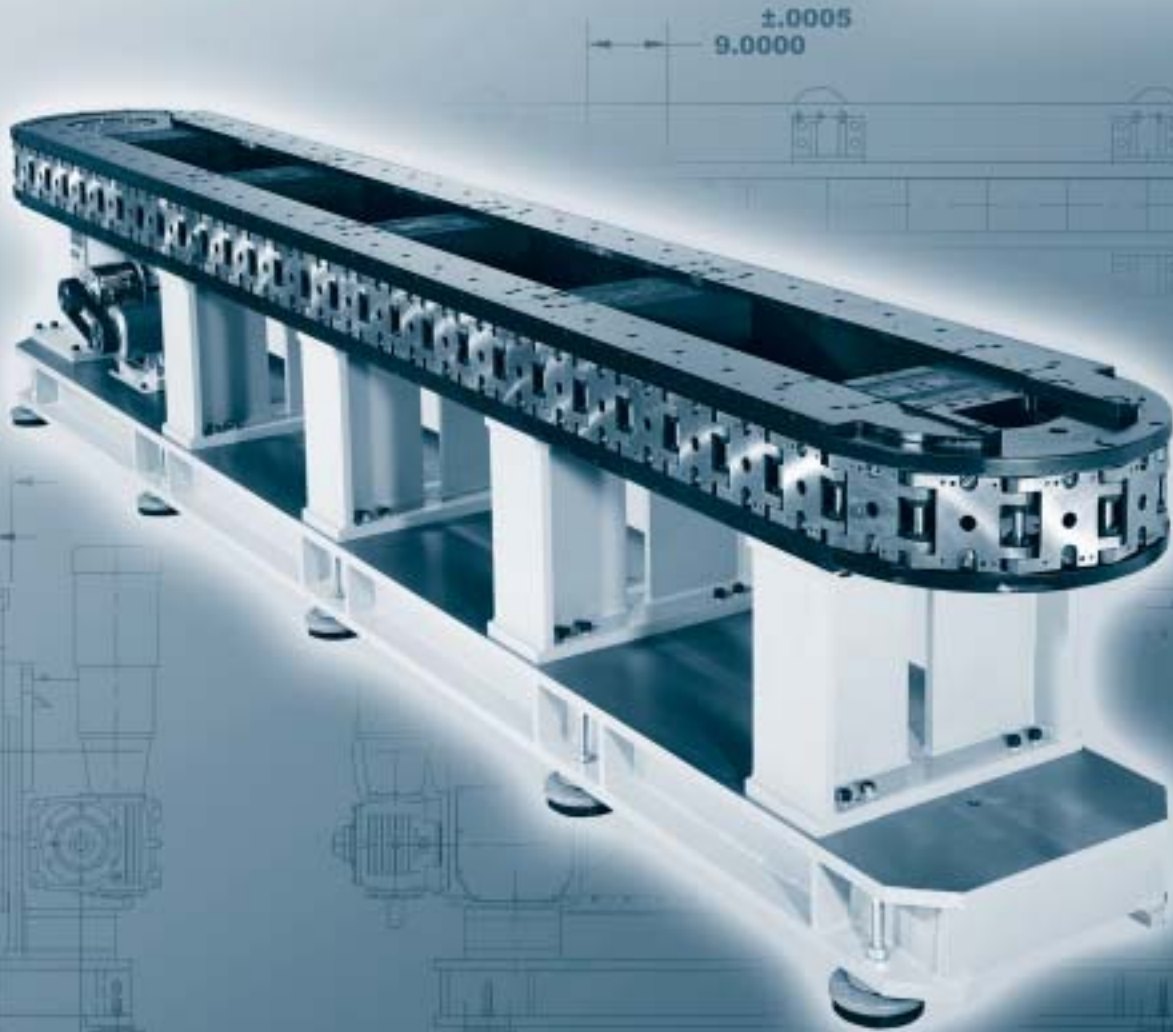

Features

IMC Precision Link Conveyors are ideal for linear transfer applications with features including:

- ◆ Table Top or Heavy Duty versions
- ◆ Precision positioning of parts for assembly or manufacturing processes
- ◆ High Speed station to station parts transfer
- ◆ Precision Links with roller bearings and precision ground cam followers for smooth transfer and long life
- ◆ Link size range to meet most application requirements
- ◆ Optional Bases, Line Shafts and Tooling Mounting Plates
- ◆ Complete with Motorized Index Drive system including transfer overload protection.

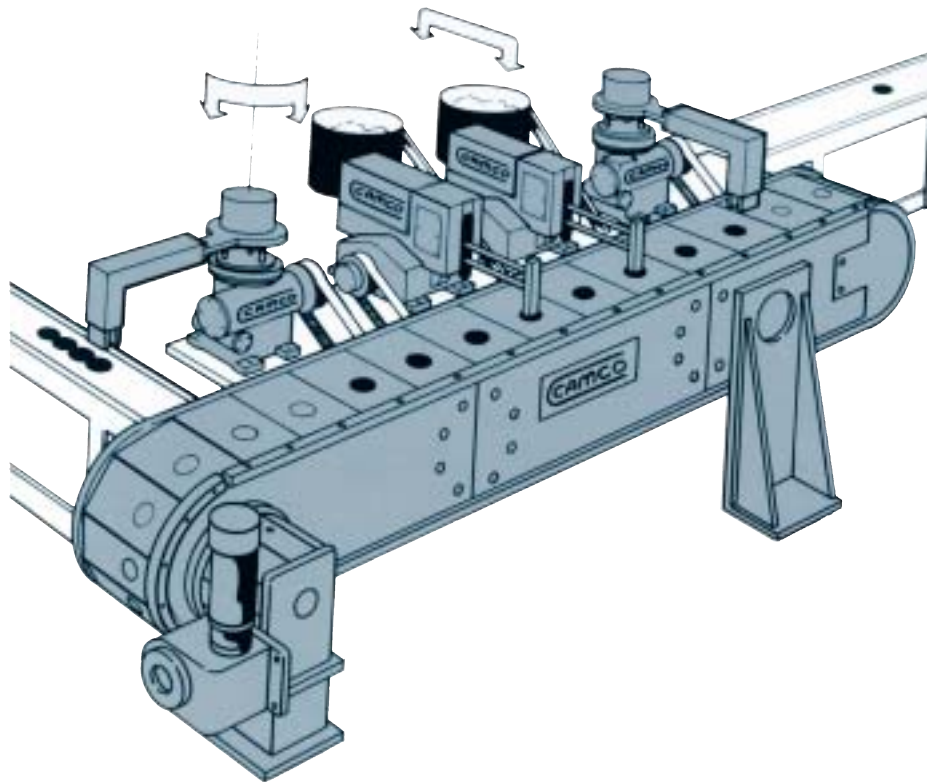

J

Precision Link Conveyors

IMC Precision Link Conveyors combine excellent accuracy and high load capability with versatility to meet any automation challenge. In combination with a IMC index drive package and IMC parts handlers, these conveyors can be relied on as the cornerstone of in-line automatic assembly applications.

High Speed and Accuracy

Precision-machined conveyor chain links are driven by a high-performance IMC Index Drive. The Conveyors are equipped with a precision machined chordal compensation cam which maintains a precise tension level in the link assembly at all times for high accuracy and speed capability

Versatility

Many Precision Link Conveyors features can be customized including conveyor length, index distance, index motion, link fixture mounting pattern, drive package component and drive package arrangement. In addition, custom options include tooling plates, line shafts, and custom bases.

Customization

To suit your needs, IMC will design and build your entry precision conveyor sub-assembly, ready for your tooling. IMC parts handlers and auxiliary index drives can be mounted to work synchronously with the conveyor. IMC quality in every component ensures the highest accuracy and durability for your automation application.

Precision Links

Each link of a precision conveyor is machined to IMC's exacting standards. Roller bearings are built into the link for smooth pivotal action between each link. Precise positioning is guaranteed by hardened ground cam followers pre-loaded against precision ground tracks in the conveyor body. All bearings are greased and sealed for ease of maintenance and extended life.

Easy to Tool

Optional tooling and parts handler mounting surfaces are available for easy, convenient machine building.

Compact Design

In-line design saves floor space and provides maximum accessibility for tooling. Both Over/Under and Carousel design are available in lengths to meet your needs.

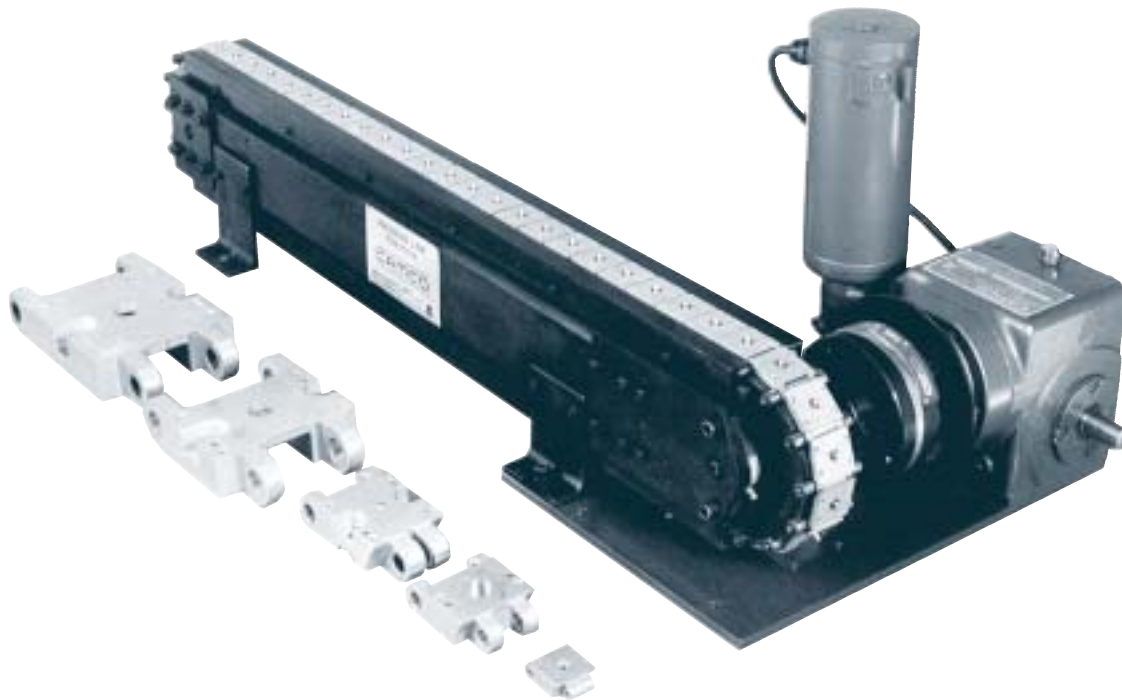

Table Top Precision Link Conveyors

IMC Table Top Precision Link Conveyors are available in a variety of standard configurations. Standard link lengths include: 1.5", 2.0", 3.0", 4.5" and 6.0".

Table Top Conveyor Modules are available with and without a drive package. They can be oriented in any direction without affecting capacity, accuracy or ease of maintenance. Typically, they are mounted directly to the top surface or wall of your machined base.

Table Top Conveyor drive packages feature a shrink-disk mounted output overload clutch offering a zero-backlash connection between the indexer and the conveyor. It also provides phase adjustability and added protection for the indexer.

The Table Top Conveyor configurations shown here are intended as a general guideline in the design of your automation system. Your IMC Sales Agent will help you determine any options or customer modification you may require.

1.5 Basic Module

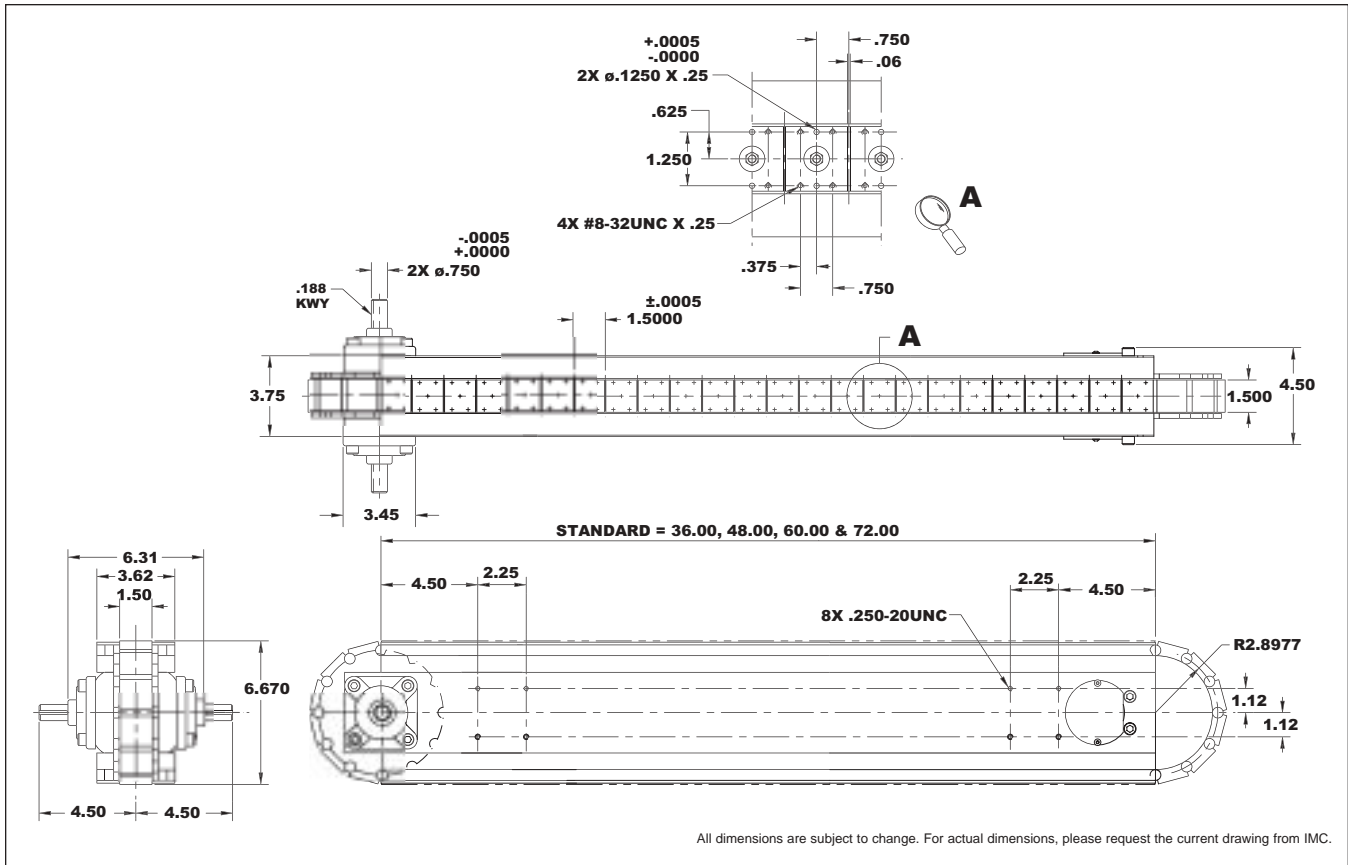

J

Standard Drive Package (Over/Under & Carousel)

- ◆ 400RA Index Drive
- ◆ 2.3FC-SD Overload Clutch
- ◆ R180 Gear Reducer
- ◆ 1/3 hp DC Motor
- ◆ Varipak DC Motor Control

Heavy Duty Drive Package (Over/Under)

- ◆ 250P Index Drive
- ◆ .39FC-SD Overload Clutch
- ◆ R180 Gear Reducer
- ◆ 1/3 hp DC Motor
- ◆ Varipak DC Motor Control

Index Distance (in.)	Indexer Stops
1.5	12
3	6
4.5	4
6	3
9	2

1.5 Carousel

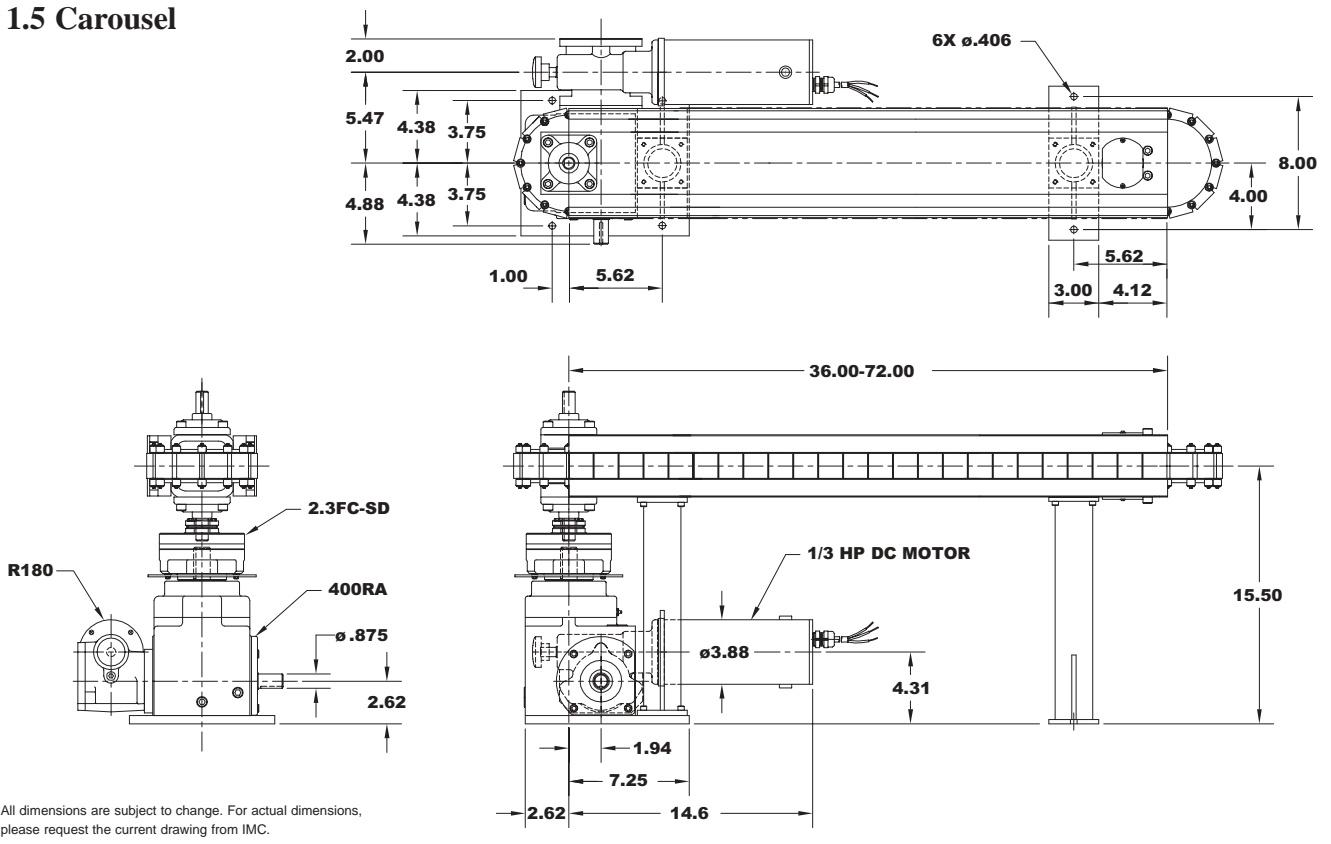

1.5 Over/Under

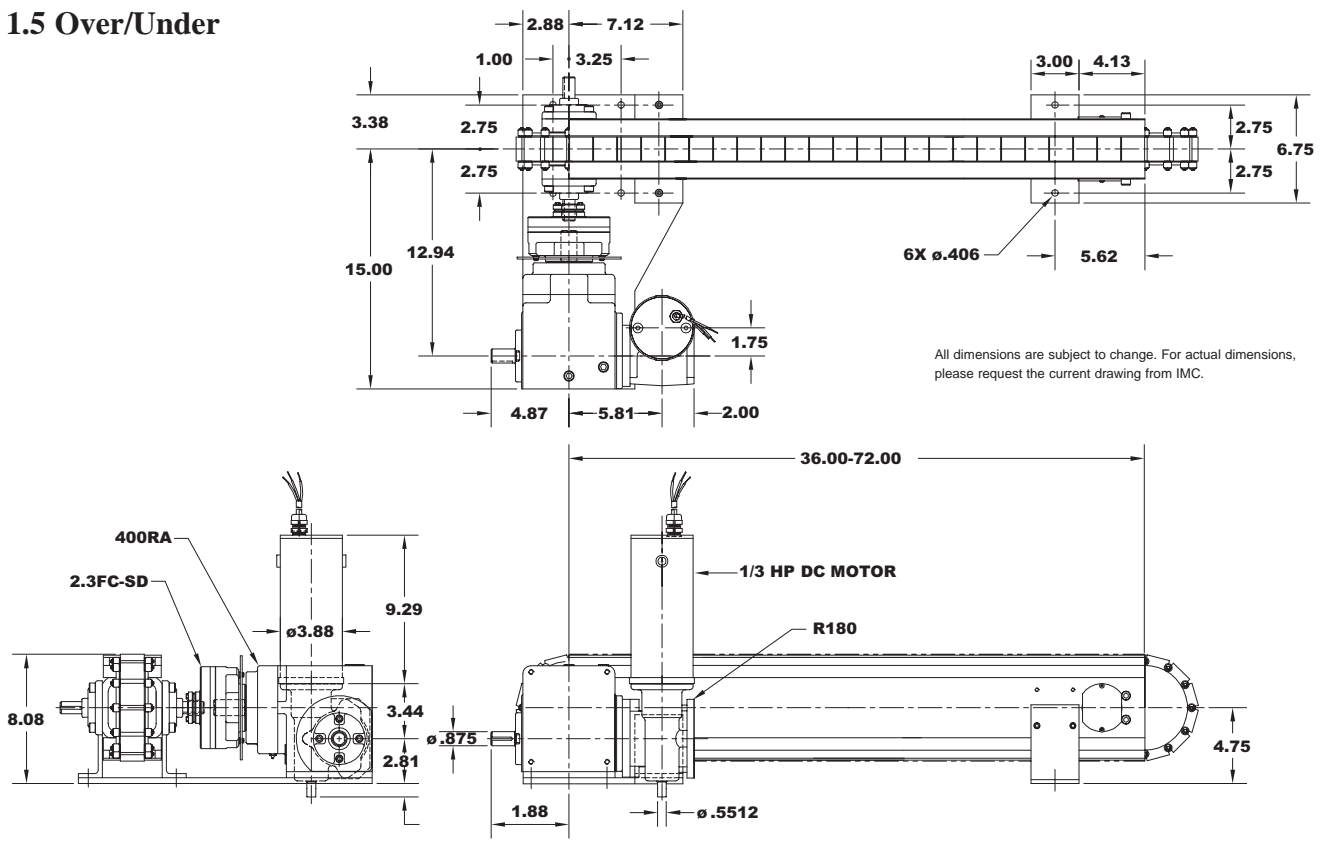

2.0 Basic Module

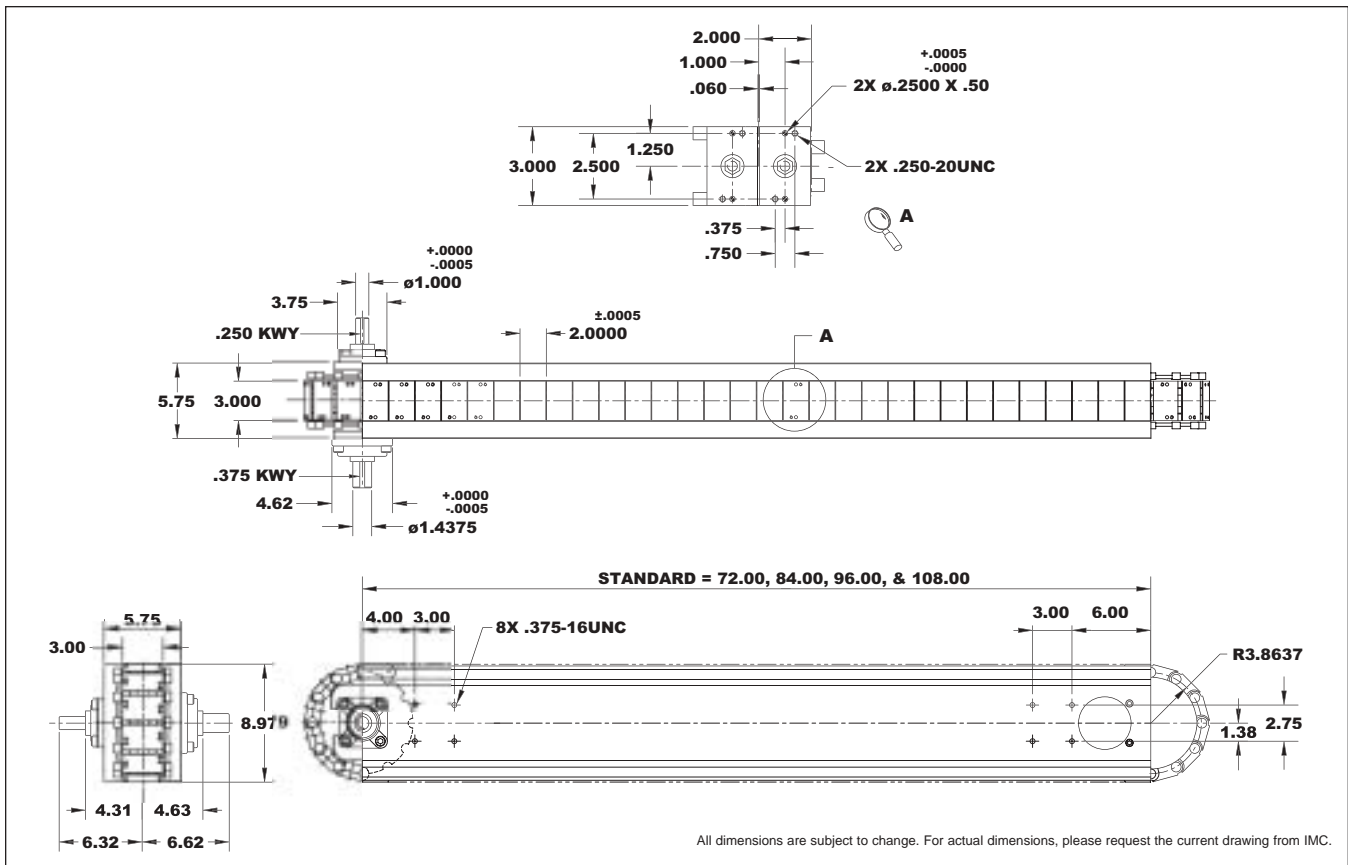

Standard Drive Package (Over/Under & Carousel)

- ◆ 401RA Index Drive
- ◆ 2.3FC-SD Overload Clutch
- ◆ R225 Gear Reducer
- ◆ 1 hp DC Motor
- ◆ Varipak DC Motor Control

Heavy Duty Drive Package (Over/Under & Carousel)

- ◆ 512RA Index Drive
- ◆ 6.0FC-SD Overload Clutch
- ◆ R260 Gear Reducer
- ◆ 1 hp DC Motor
- ◆ Varipak DC Motor Control

Standard Drive Package (Over/Under)

- ◆ 387P Index Drive
- ◆ 2.3FC-SD Overload Clutch
- ◆ R260 Gear Reducer
- ◆ 1 hp DC Motor
- ◆ Varipak DC Motor Control

Heavy Duty Drive Package (Over/Under)

- ◆ 512P Index Drive
- ◆ 6.0FC-SD Overload Clutch
- ◆ R260 Gear Reducer
- ◆ 1 hp DC Motor
- ◆ Varipak DC Motor Control

Index Distance (in.)	Indexer Stops
2	12
4	6
6	4
8	3

2.0 Carousel

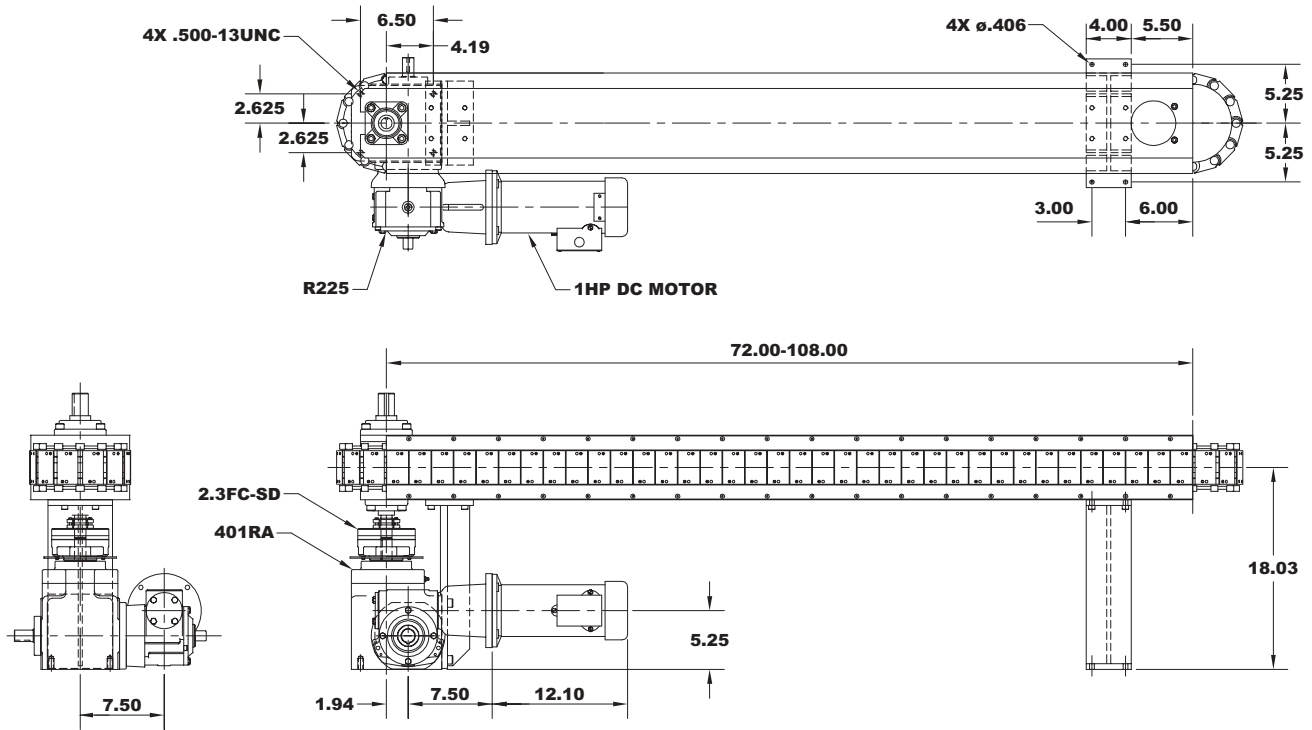

All dimensions are subject to change. For actual dimensions, please request the current drawing from IMC.

2.0 Over/Under

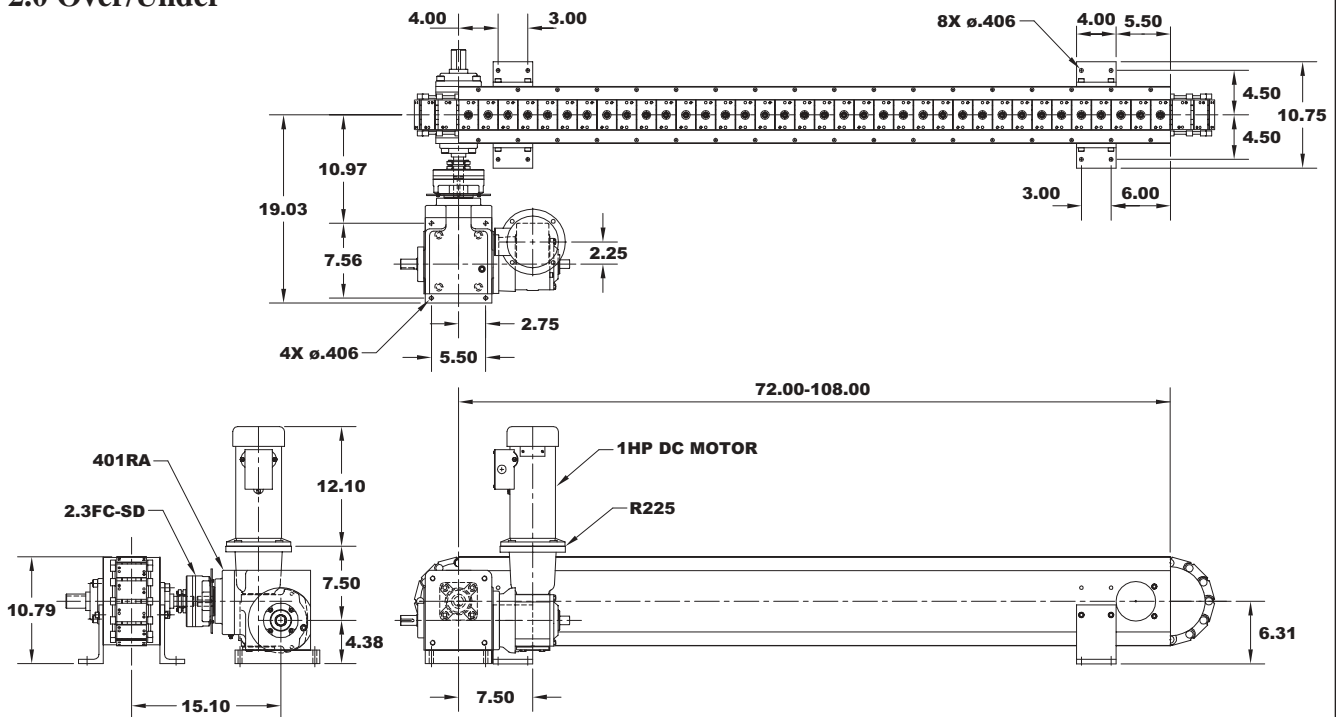

All dimensions are subject to change. For actual dimensions, please request the current drawing from IMC.

3.0 Basic Module

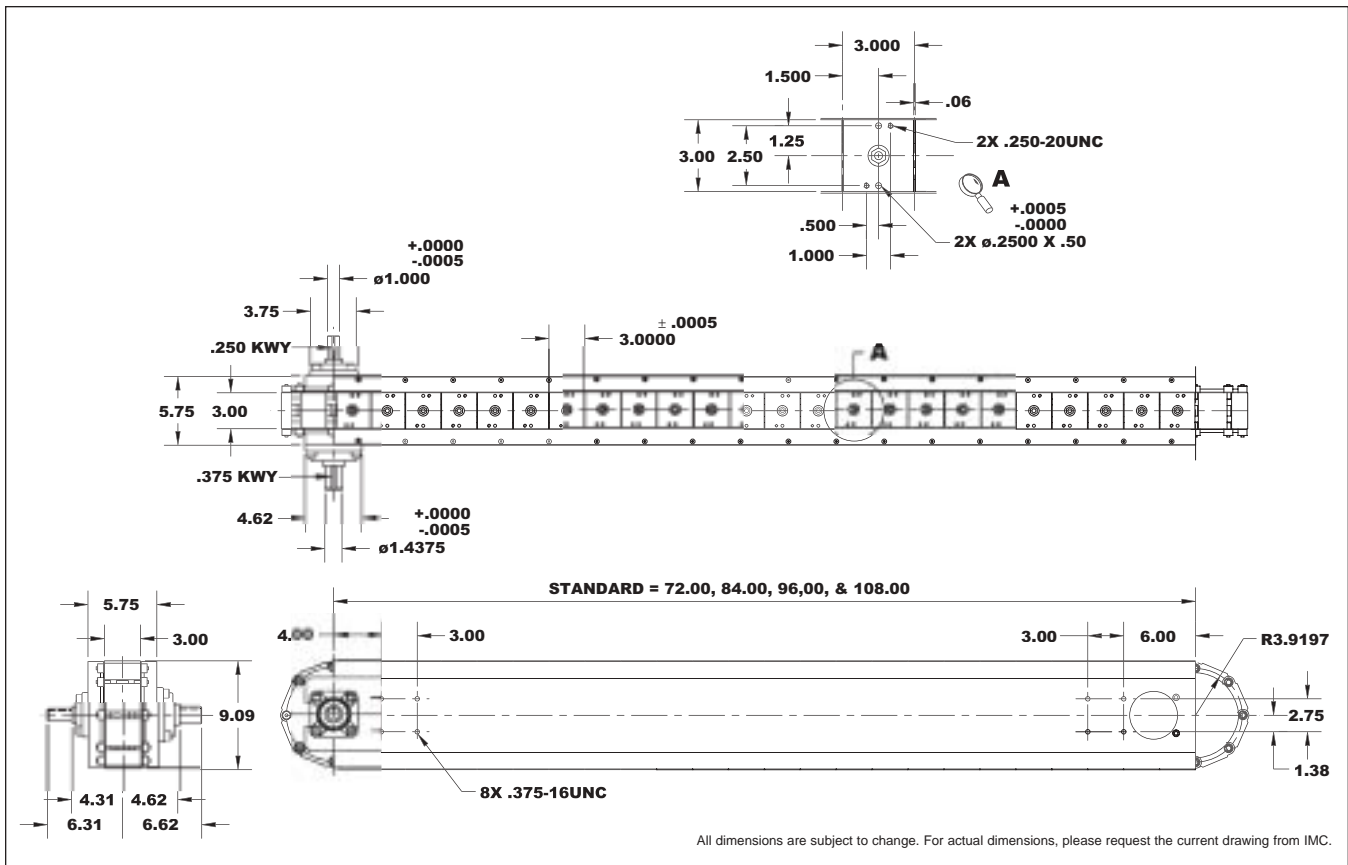

J

Standard Drive Package (Over/Under & Carousel)

- ◆ 401RA Index Drive
- ◆ 2.3FC-SD Overload Clutch
- ◆ R225 Gear Reducer
- ◆ 1 hp DC Motor
- ◆ Varipak DC Motor Control

Heavy Duty Drive Package (Over/Under & Carousel)

- ◆ 512RA Index Drive
- ◆ 6.0FC-SD Overload Clutch
- ◆ R260 Gear Reducer
- ◆ 1 hp DC Motor
- ◆ Varipak DC Motor Control

Standard Drive Package (Over/Under)

- ◆ 387P Index Drive
- ◆ 2.3FC-SD Overload Clutch
- ◆ R260 Gear Reducer
- ◆ 1 hp DC Motor
- ◆ Varipak DC Motor Control

Heavy Duty Drive Package (Over/Under)

- ◆ 512P Index Drive
- ◆ 6.0FC-SD Overload Clutch
- ◆ R260 Gear Reducer
- ◆ 1 hp DC Motor
- ◆ Varipak DC Motor Control

Index Distance (in.)	Indexer Stops
3	8
6	4
9	2 2/3*
12	2

* Not available in Parallel Indexers.

3.0 Carousel

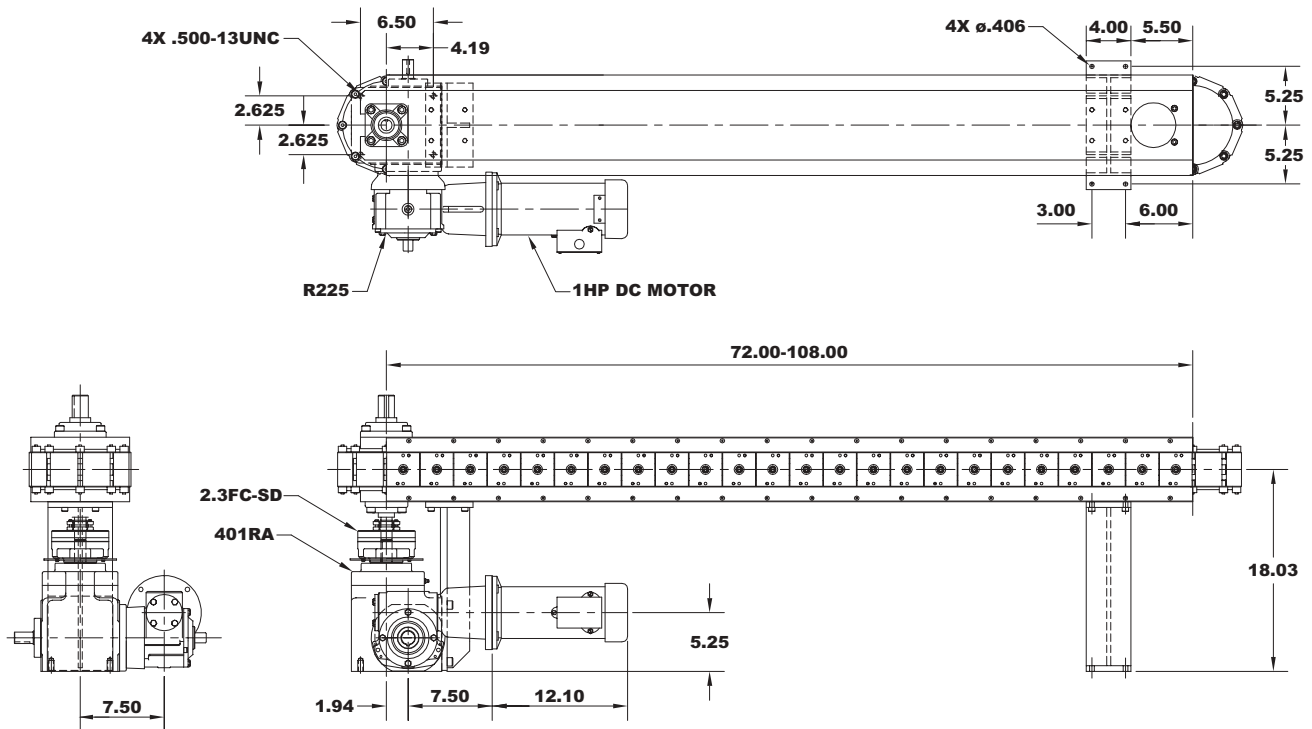

All dimensions are subject to change. For actual dimensions, please request the current drawing from IMC.

3.0 Over/Under

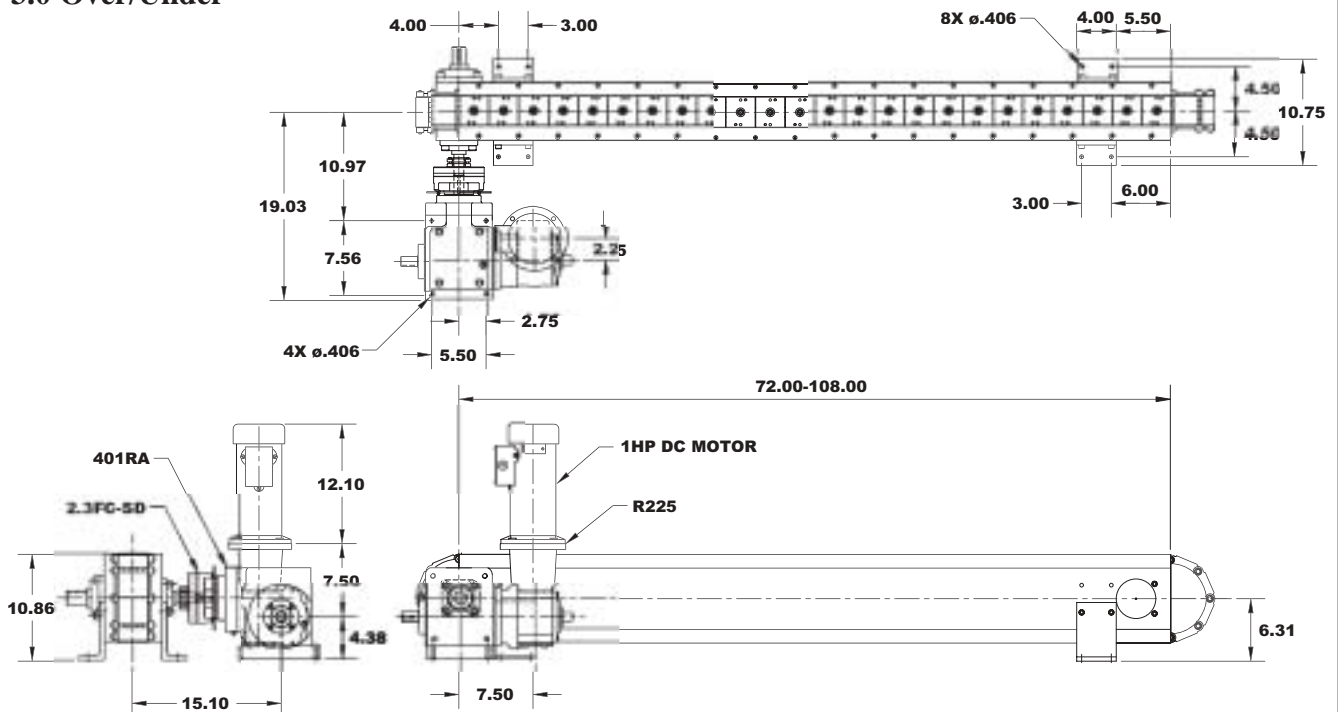

All dimensions are subject to change. For actual dimensions, please request the current drawing from IMC.

J

4.5 Basic Module

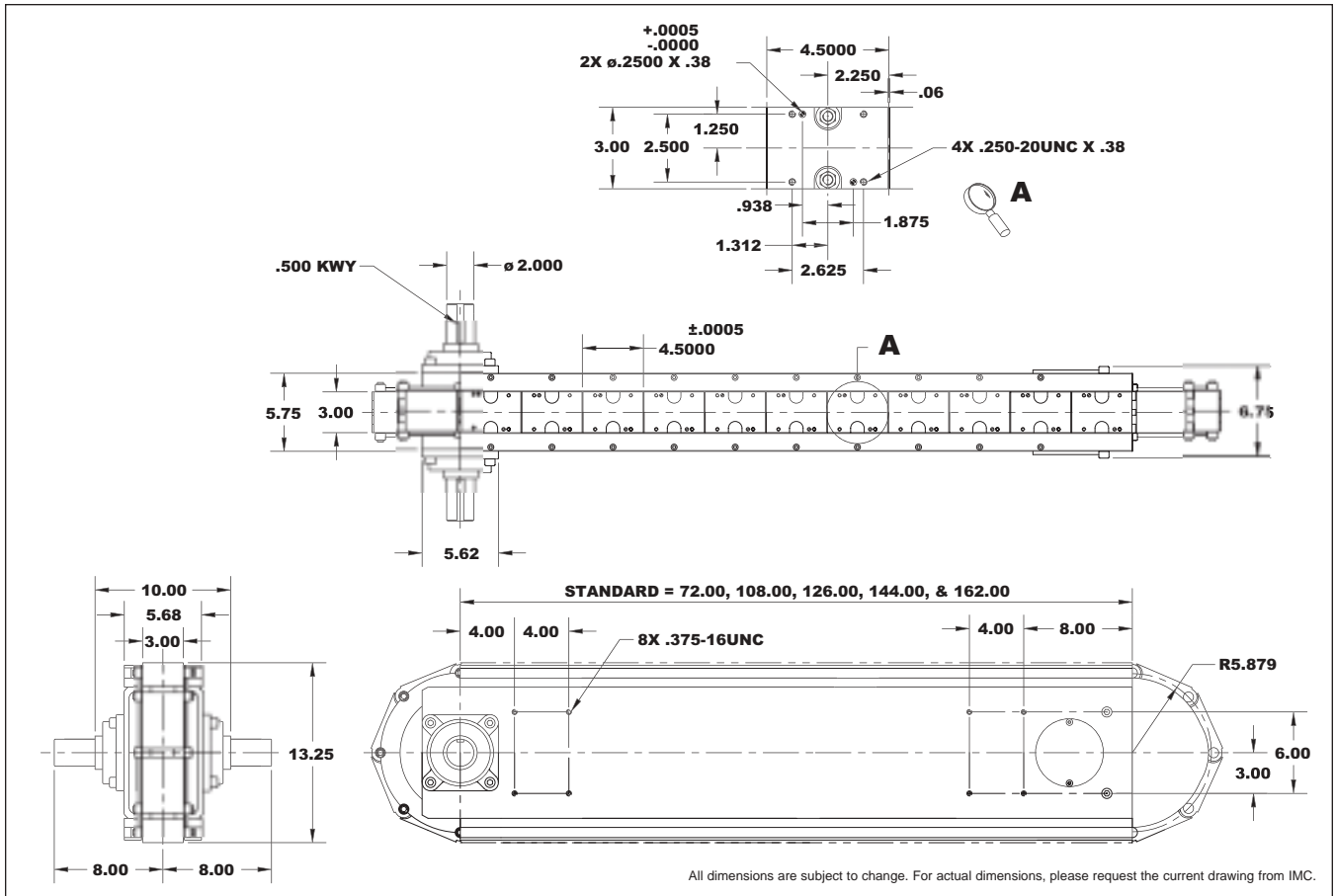

Standard Drive Package (Over/Under)

- ◆ 662RA Index Drive
- ◆ 11FC-SD Overload Clutch
- ◆ 7300C Gear Reducer
- ◆ 1 hp DC Motor
- ◆ Varipak DC Motor Control

Standard Drive Package (Carousel)

- ◆ 500RGD Index Drive
- ◆ 11FC-SD Overload Clutch
- ◆ 7300C Gear Reducer
- ◆ 1 hp DC Motor
- ◆ Varipak DC Motor Control

Index Distance (in.)	Indexer Stops
4.5	8
9	4
18	2

4.5 Carousel

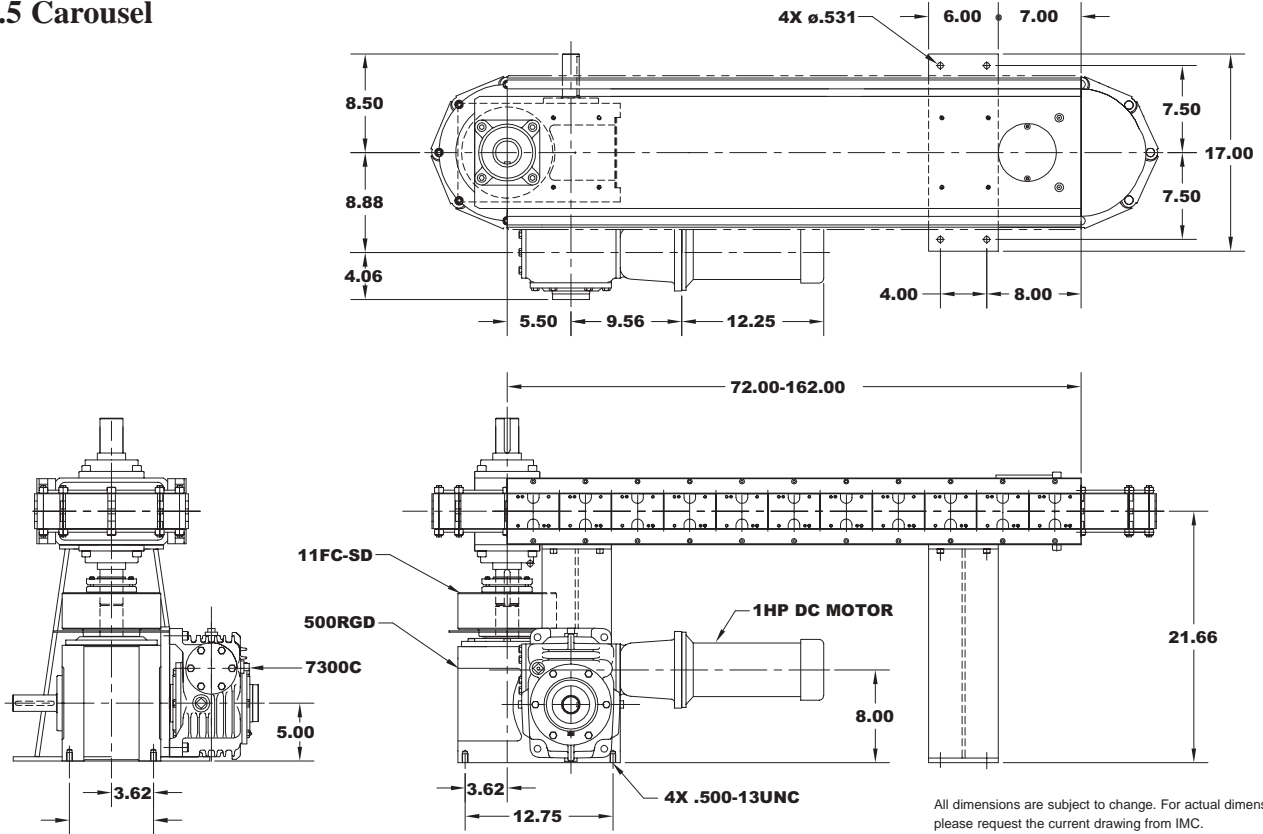

4.5 Over/Under

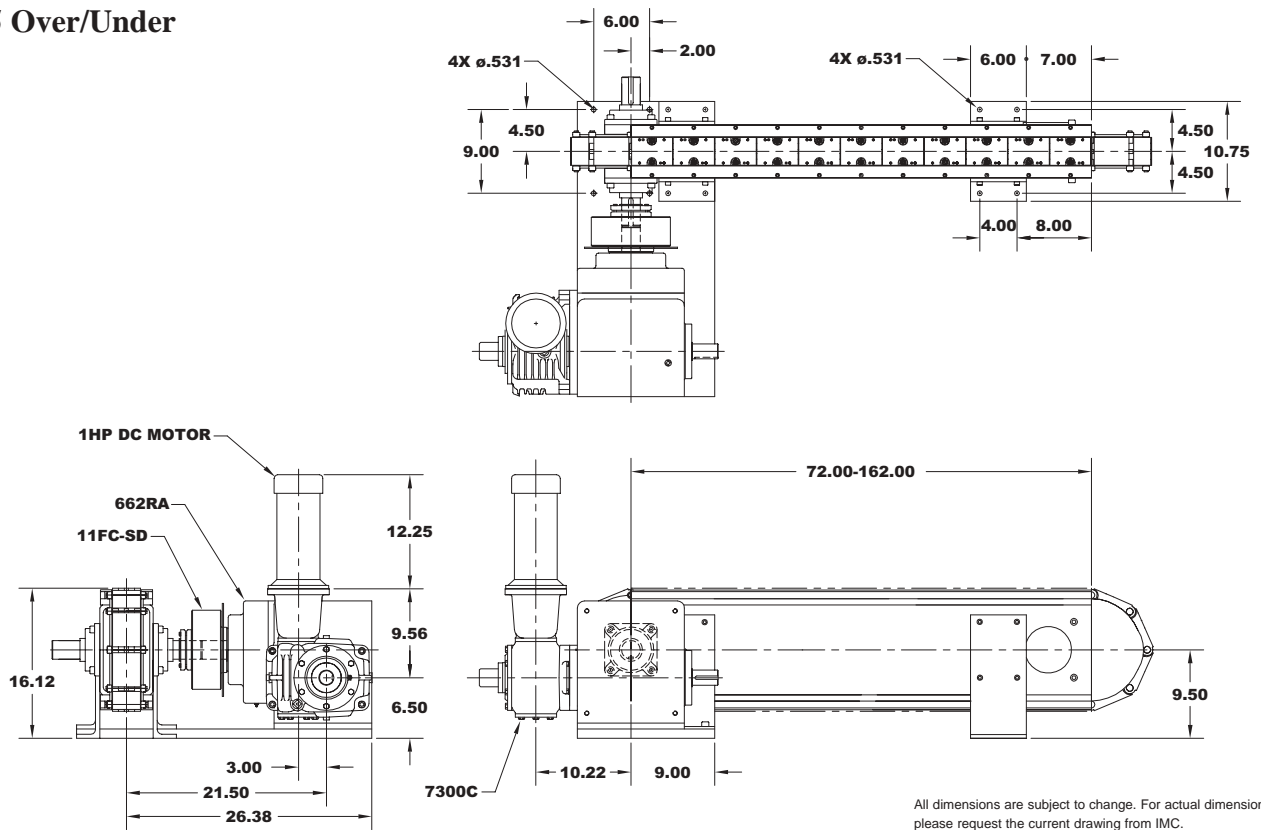

6.0 Basic Module

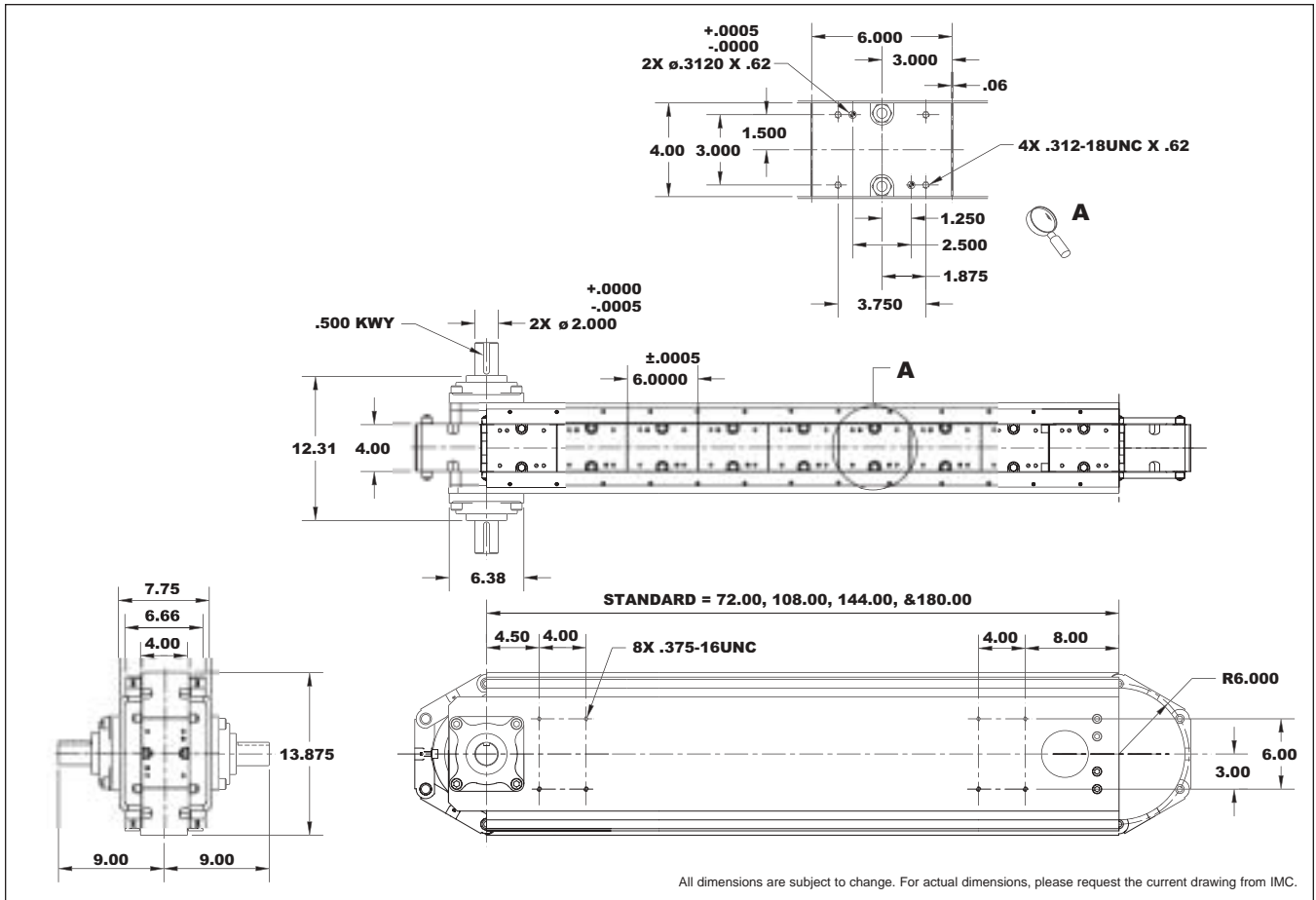

Standard Drive Package (Over/Under & Carousel)

- ◆ 662RA Index Drive
- ◆ 11FC-SD Overload Clutch
- ◆ 7300C Gear Reducer
- ◆ 1 hp DC Motor
- ◆ Varipak DC Motor Control

Heavy Duty Drive Package (Over/Under & Carousel)

- ◆ 800RD Index Drive
- ◆ 25FC-SD Overload Clutch
- ◆ 7300C Gear Reducer
- ◆ 1 hp DC Motor
- ◆ Varipak DC Motor Control

Standard Drive Package (Over/Under)

- ◆ 662RA Index Drive
- ◆ 11FC-SD Overload Clutch
- ◆ 7300C Gear Reducer
- ◆ 1 hp DC Motor
- ◆ Varipak DC Motor Control

Index Distance (in.)	Indexer Stops
6	6
12	3
18	2

6.0 Carousel

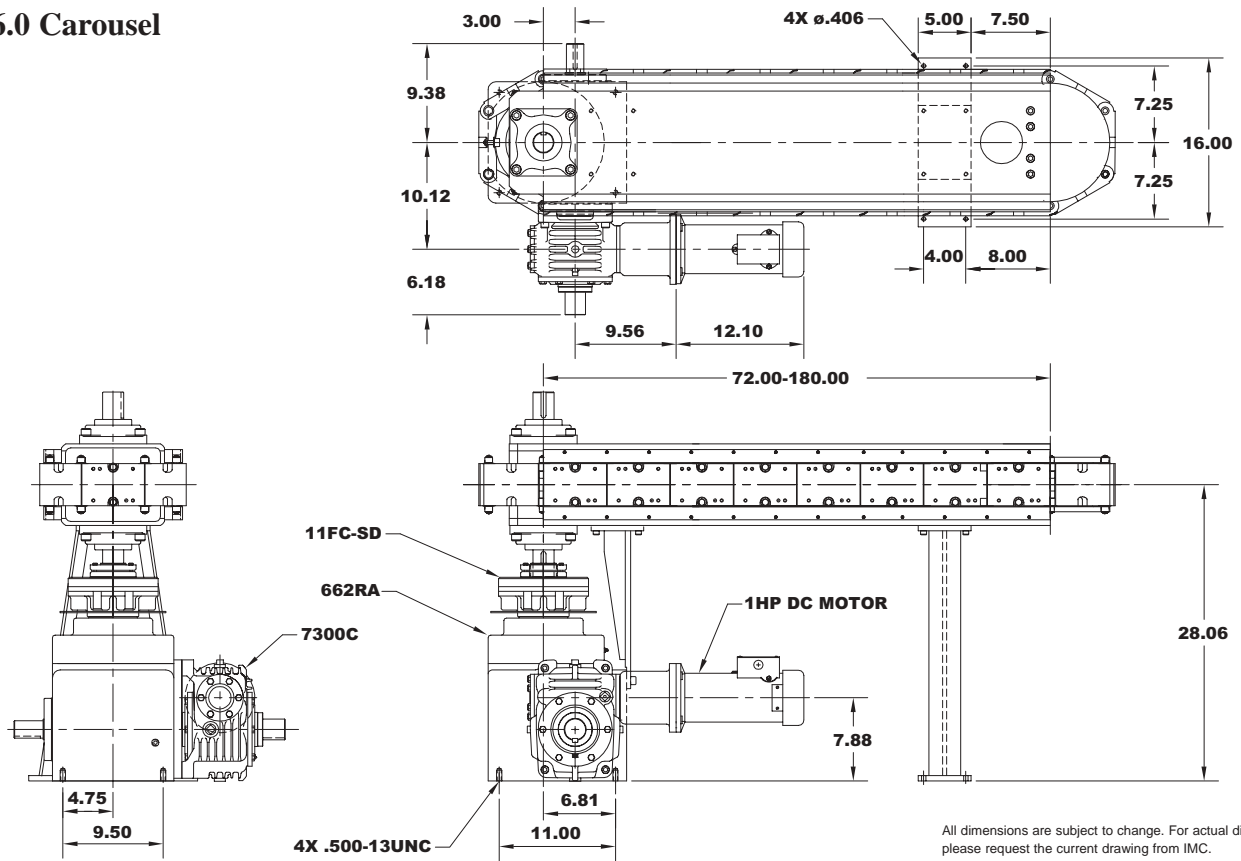

All dimensions are subject to change. For actual dimensions, please request the current drawing from IMC.

6.0 Over/Under

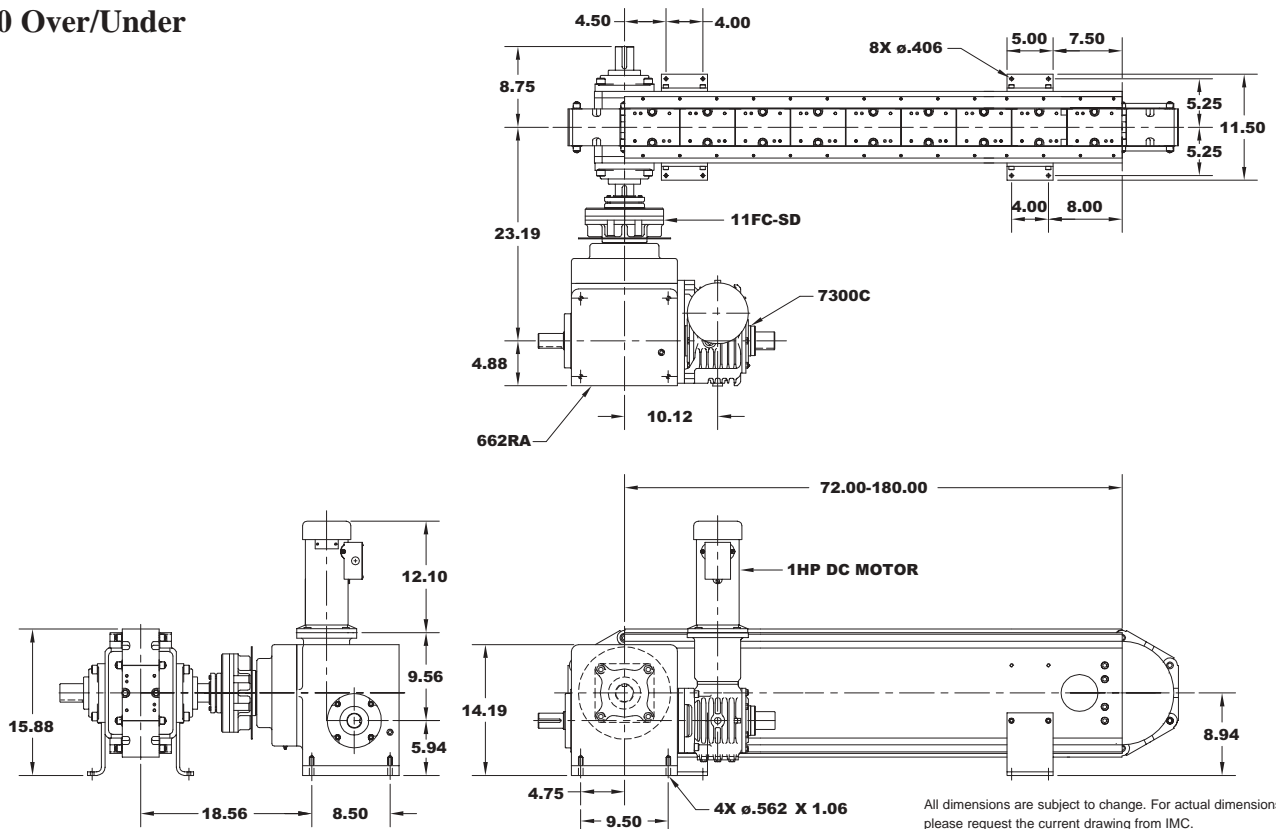

All dimensions are subject to change. For actual dimensions, please request the current drawing from IMC.

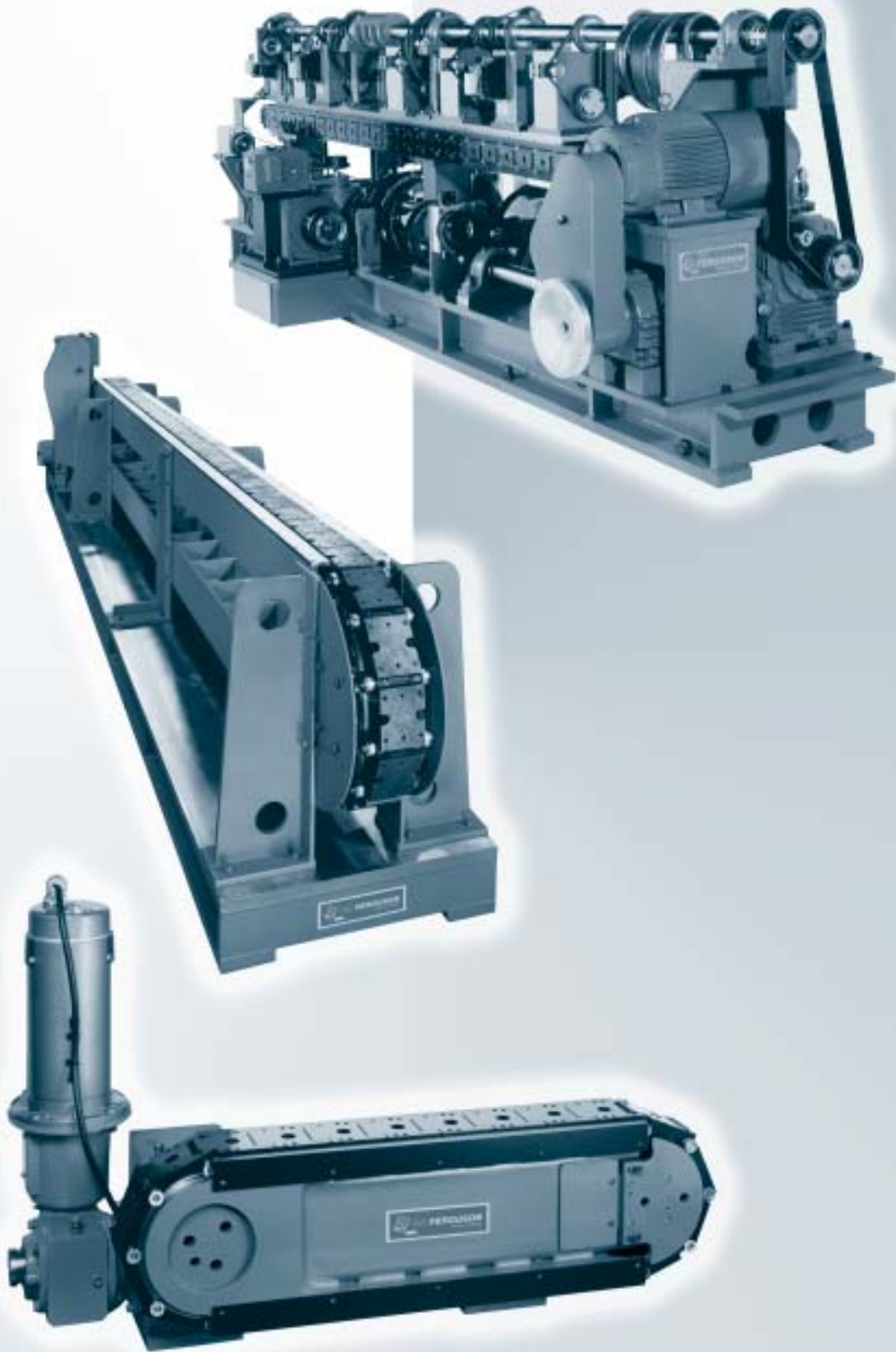

J

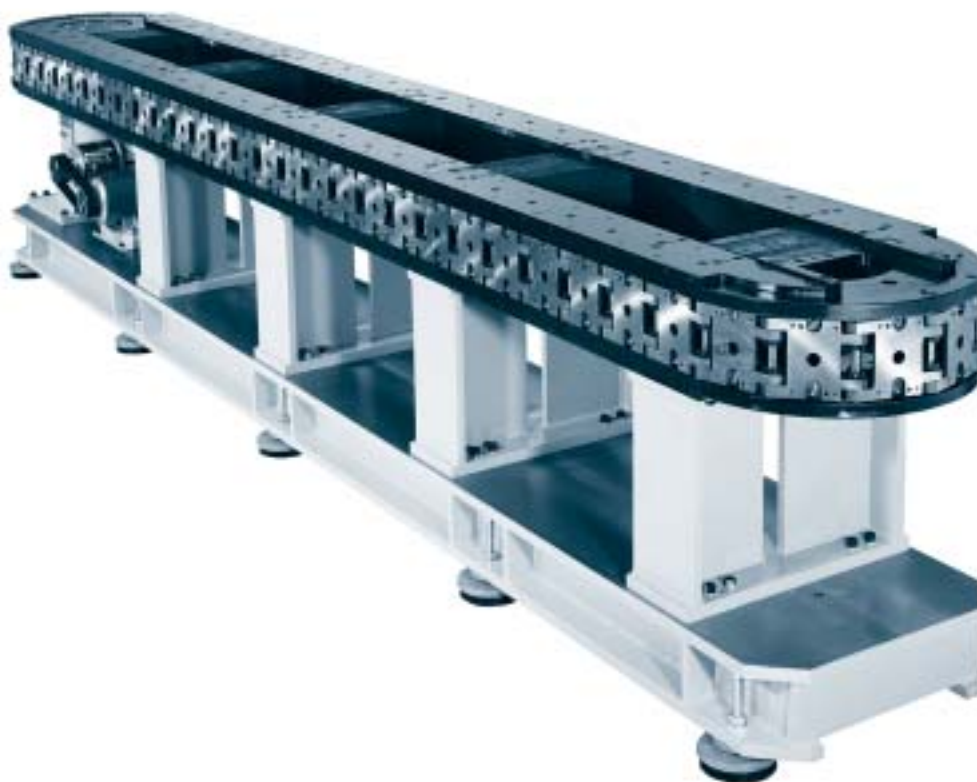

Heavy Duty Precision Link Conveyors

IMC Heavy Duty Precision Link Conveyors are available with standard link lengths of 6.0", 9.0" and 12". They are available in Over/Under and Carousel configurations. Both configurations include heavy-duty legs and a precision machined base designed to hold large loads and maintain system accuracy. Adjustable soft machine mounts are available on the base to accommodate inconsistent on-site flooring.

The conveyor is available with either an "open backbone" or "closed backbone" design. The open backbone allows for convenient passage of tooling, drive shafts, timing belts, and hydraulic, air or electrical lines through the center of the conveyor. The closed backbone design is ideally suited to mounted IMC parts handlers and tooling plates and offers increased rigidity.

Like the Table Top Series, Heavy Duty Conveyors can be mounted in any direction simply by modifying the supports with no change in accuracy, load capacity or maintenance requirements.

The Heavy Duty Conveyor configurations shown here are intended as a general guideline in the design of your automation system. Your IMC Sales Agent will help you determine any options or customer modification you may require.

6.0HD LINK

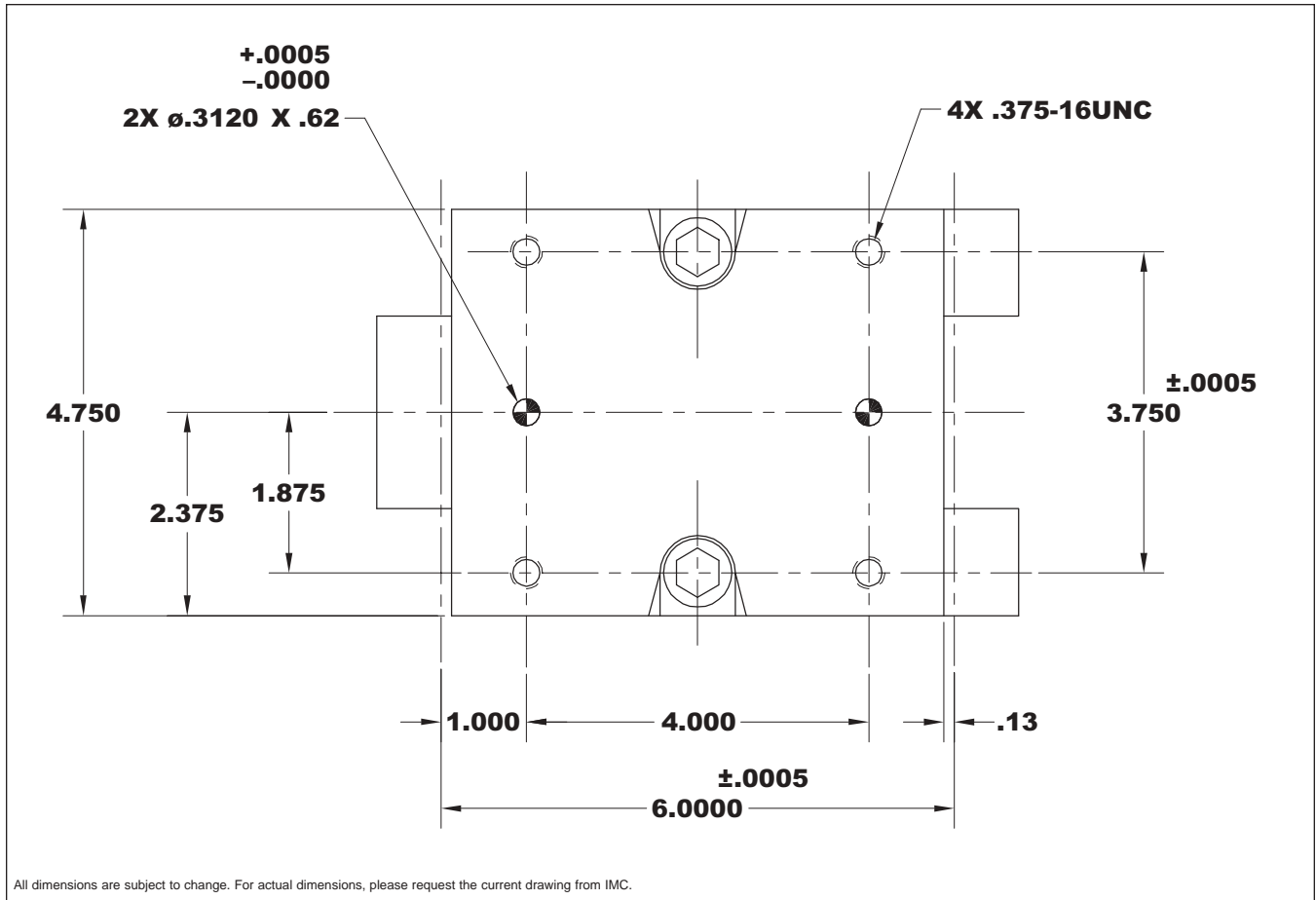

J

Standard Drive Package

- ◆ 242 Intermittor Index Drive
- ◆ R400 Reducer
- ◆ 5 hp AC Motor
- ◆ MDB-1125 Air Clutch-Brake
- ◆ Cycle Cam & Limit Switch

Index Distance (in.)	Indexer Stops
6	12
12	6
18	4
24	3

6.0 HD Carousel

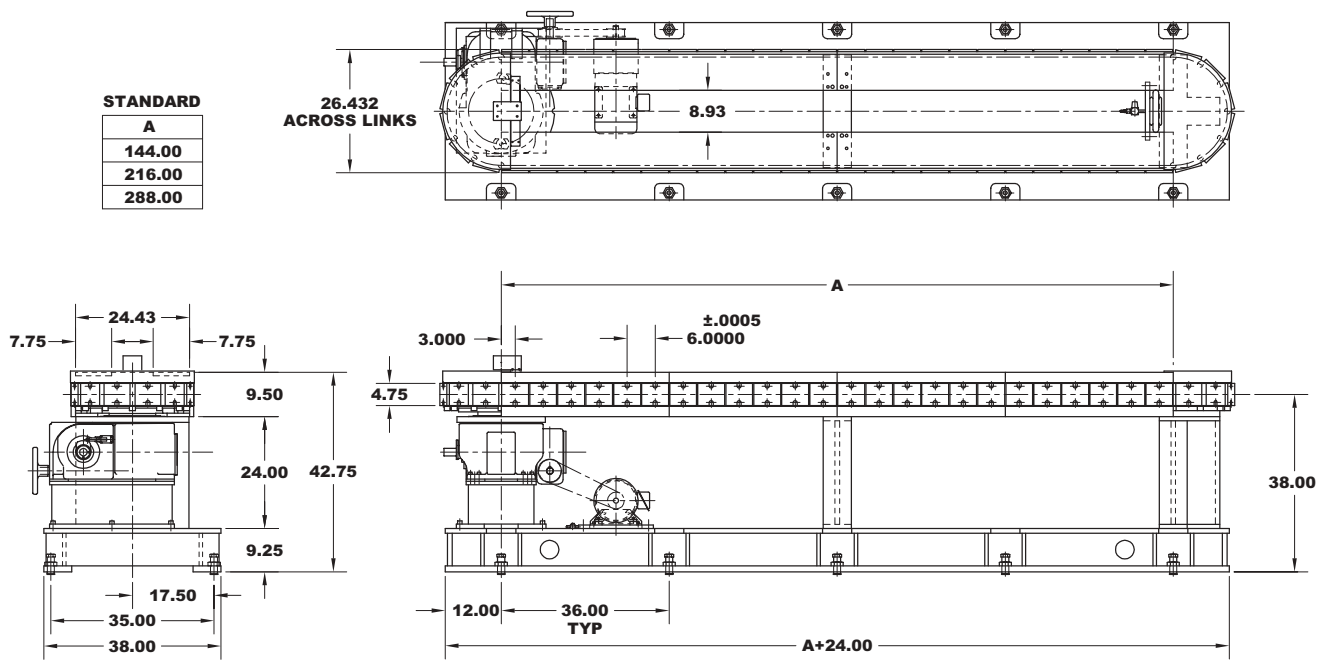

All dimensions are subject to change. For actual dimensions, please request the current drawing from IMC.

6.0HD Over/Under

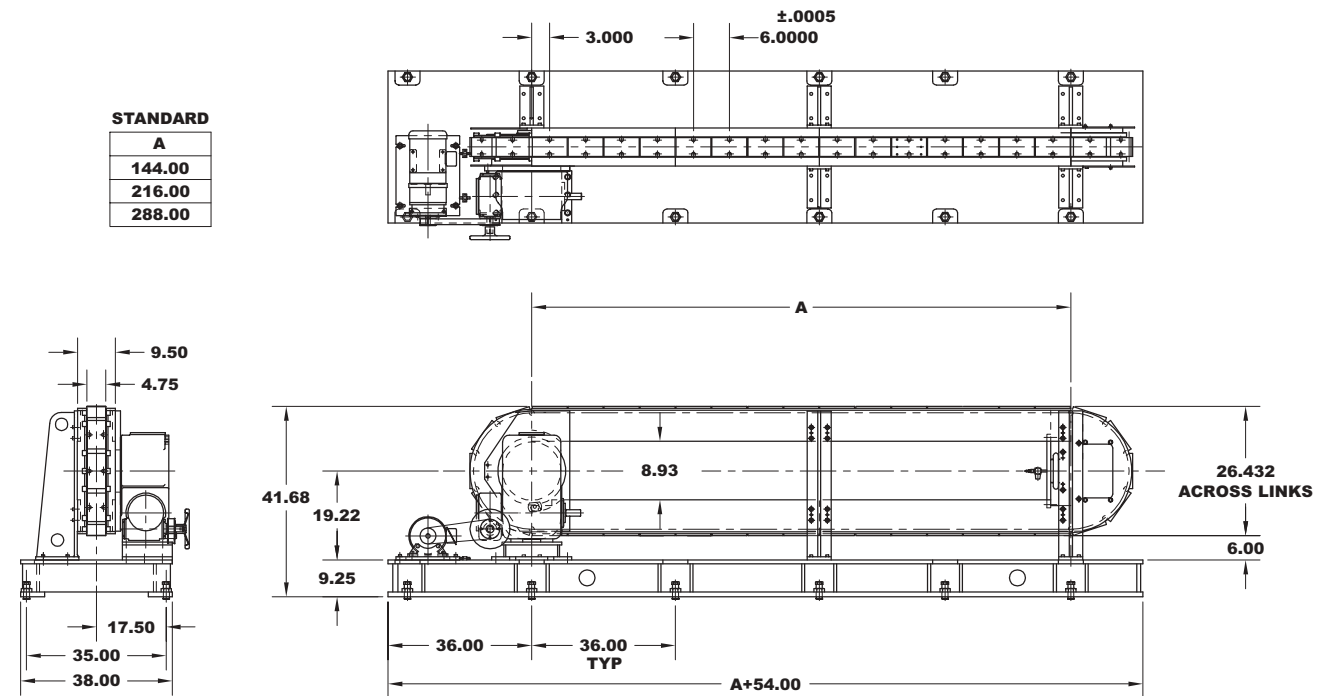

All dimensions are subject to change. For actual dimensions, please request the current drawing from IMC.

J

9.0HD LINK

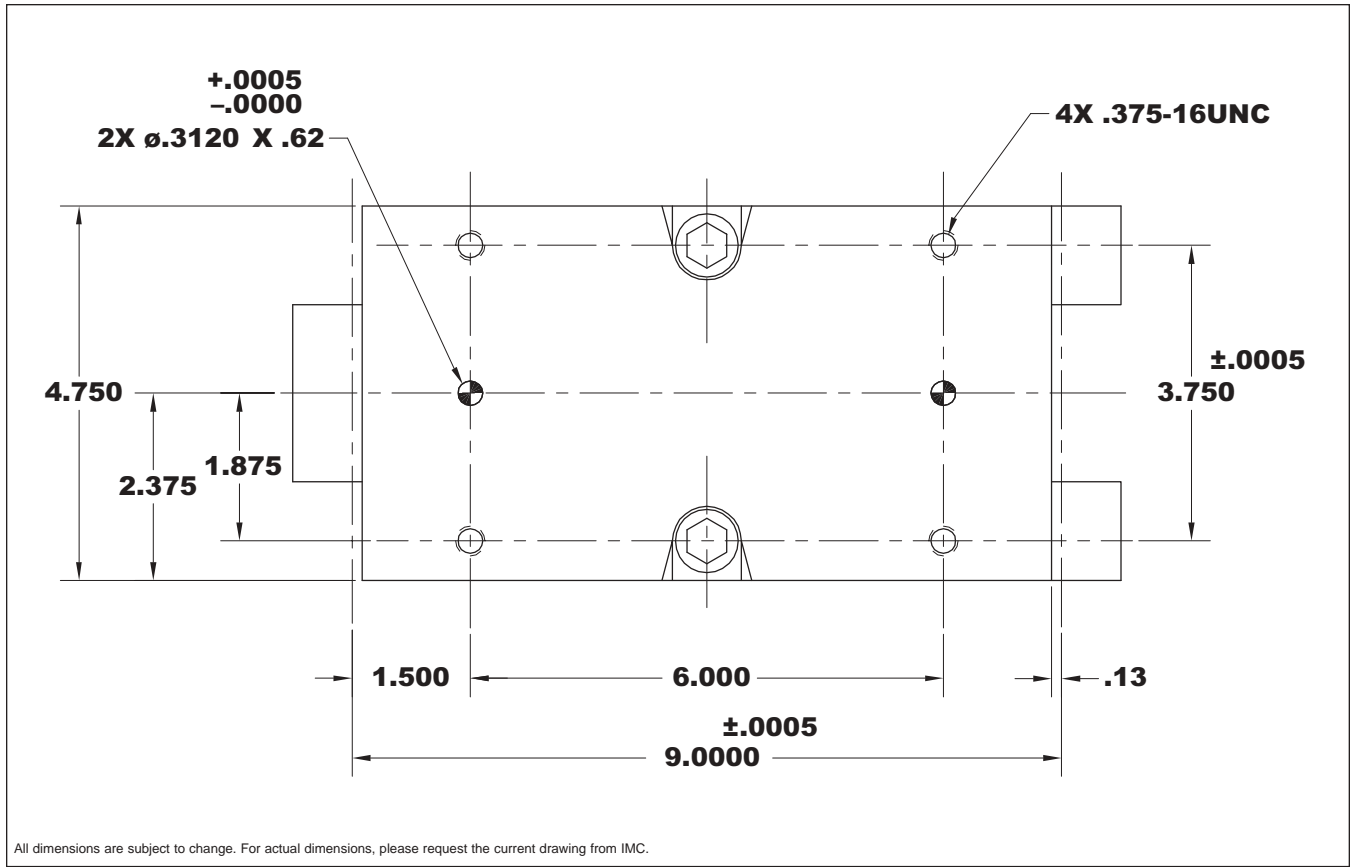

J

Standard Drive Package

- ◆ 242 Intermittor Index Drive
- ◆ R400 Reducer
- ◆ 5 hp AC Motor
- ◆ MDB-1125 Air Clutch-Brake
- ◆ Cycle Cam & Limit Switch

Index Distance (in.)	Indexer Stops
9	12
18	6
27	4
36	3

9.0 HD Carousel

STANDARD	
A	
144.00	
216.00	
288.00	

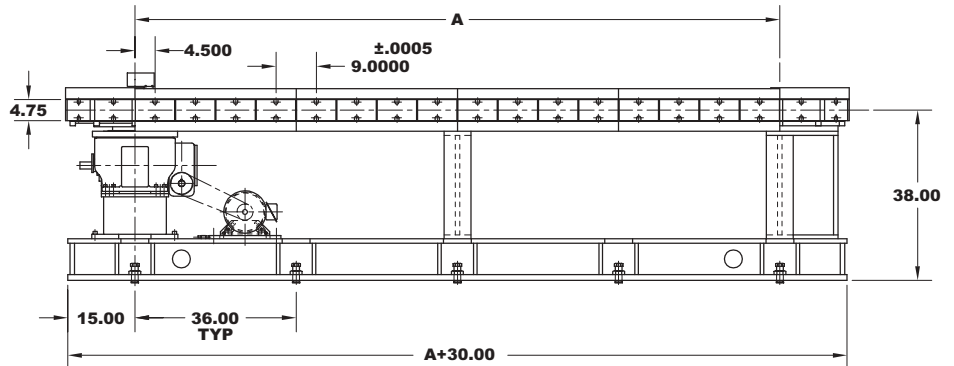
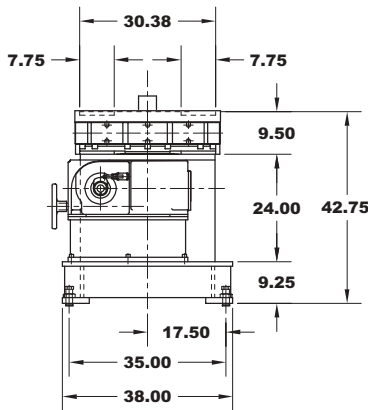
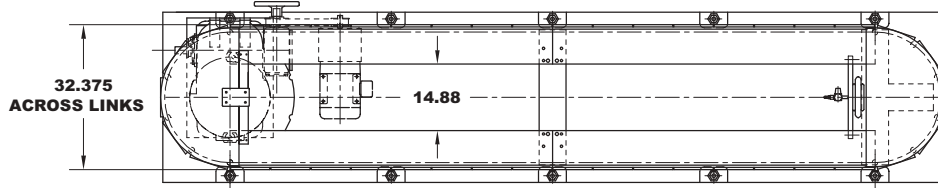

All dimensions are subject to change. For actual dimensions, please request the current drawing from IMC.

9.0HD Over/Under

STANDARD	
A	
144.00	
216.00	
288.00	

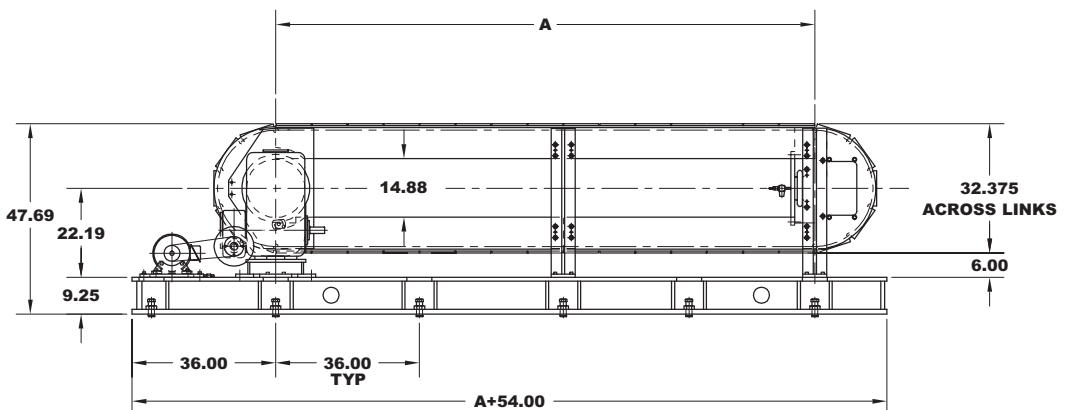
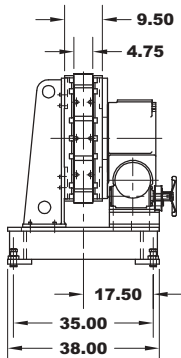
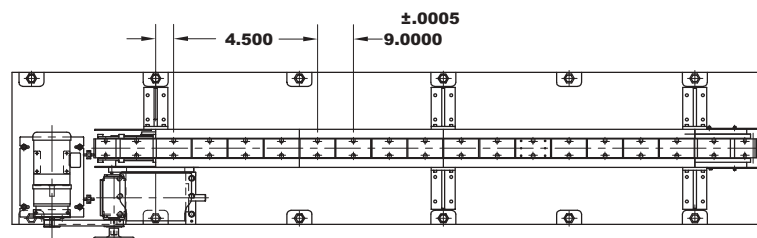

All dimensions are subject to change. For actual dimensions, please request the current drawing from IMC.

12.0HD LINK

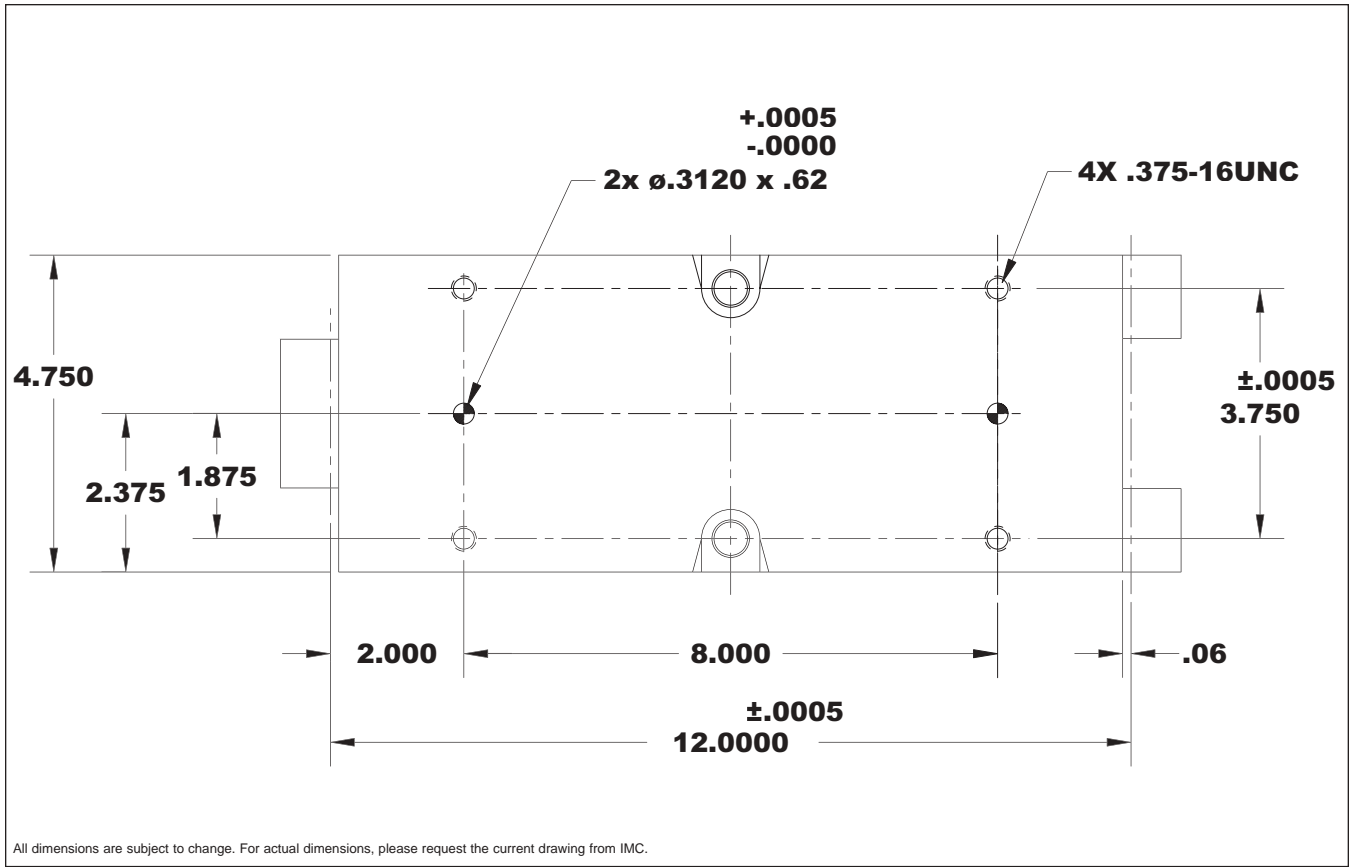

J

Standard Drive Package

- ◆ 242 Intermittor
- ◆ R5 Reducer
- ◆ 7.5 hp AC Motor
- ◆ Posidyne Clutch-Brake
- ◆ Brake Cam & Limit Switch

Index Distance (in.)	Indexer Stops	Sprocket
12	8, 10, 12	8T, 10T, 12T
24	4, 5, 6	8T, 10T, 12T
36	4	12T
48	2, 3	8T, 12T

12.0 HD Carousel

STANDARD	
A	
144.00	
216.00	
288.00	

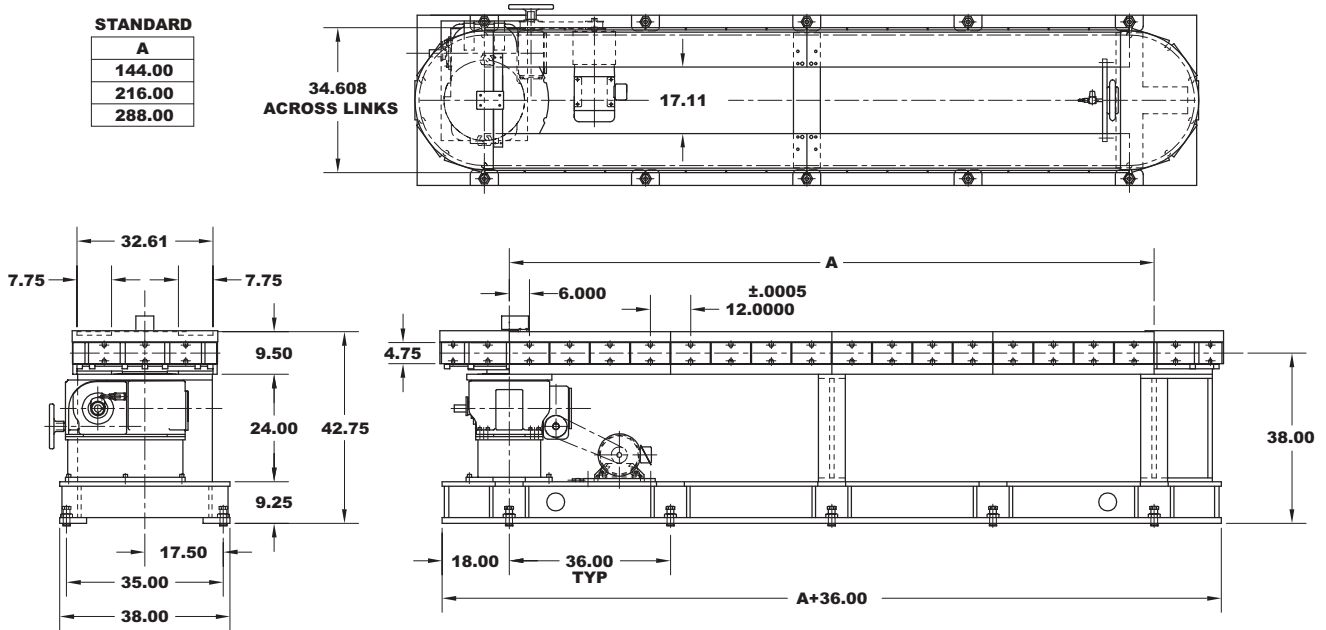

All dimensions are subject to change. For actual dimensions, please request the current drawing from IMC.

12.0HD Over/Under

STANDARD	
A	
144.00	
216.00	
288.00	

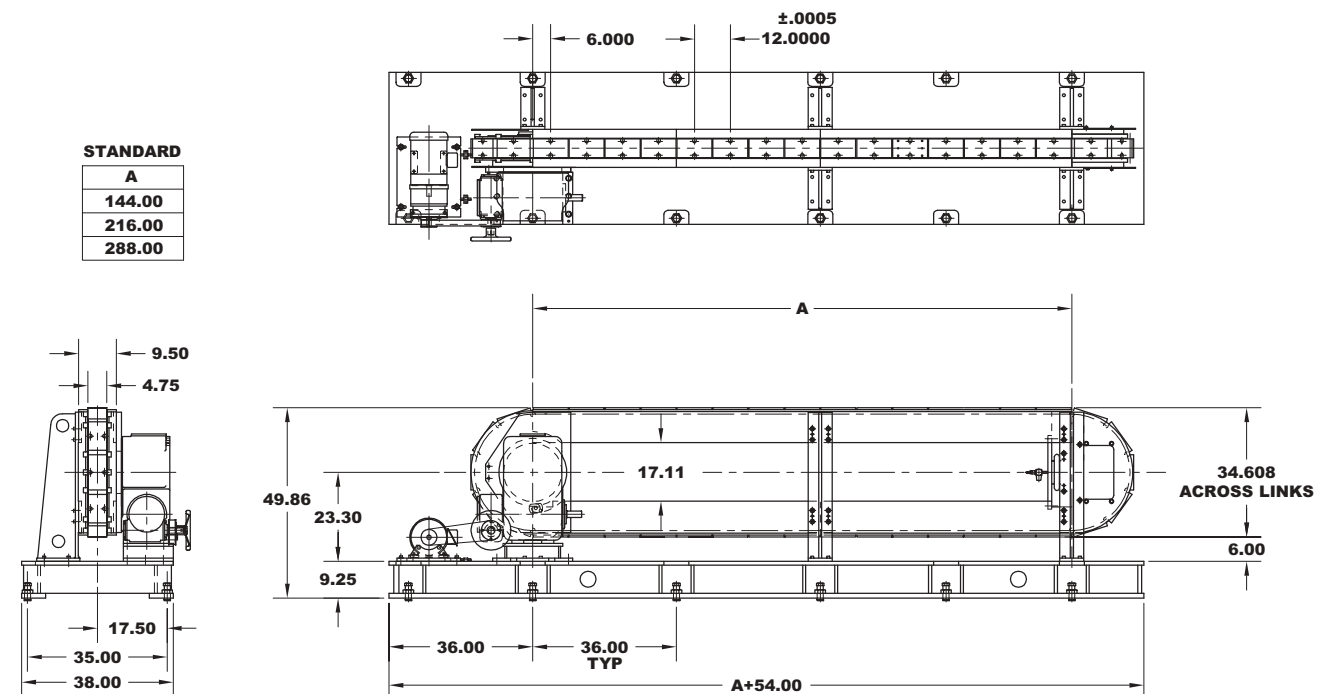

All dimensions are subject to change. For actual dimensions, please request the current drawing from IMC.

Ordering Procedure

The following ordering procedure is intended as a general guideline for the minimum information required when ordering a Precision Link Conveyor.

Your IMC Sales Agent will help you clearly specify any alterations you need to meet your design requirements.

Required Information

- ◆ **Link Size:** 1.5, 2.0, 3.0, 4.5, 6.0, 9.0 or 12.0
- ◆ **Type:** Table Top or Heavy Duty
- ◆ **Style:** Over/Under or Carousel
- ◆ **Length:** Standard per catalog or Custom, expressed as center distance, in inches
- ◆ **Height:** Standard per catalog or Custom, in inches

Required Information when ordering Drive Package

- ◆ **Type:** Standard, Alternate, Heavy-Duty or Special
- ◆ **Drive Side:** 1 or 2 (for Over/Under)
- ◆ **Index Distance:** In inches
- ◆ **Indexer Model:** Specific model number or special

Technical Assistance

All Precision Link Conveyor applications are verified by a IMC sales agent using the IMC Sizing Program.

Your IMC agent is available to make all sizing calculations for you.